

# 0082 S Full Bed

Assembly Instructions

WI-0521

## 1 Assembled View

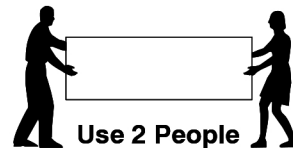
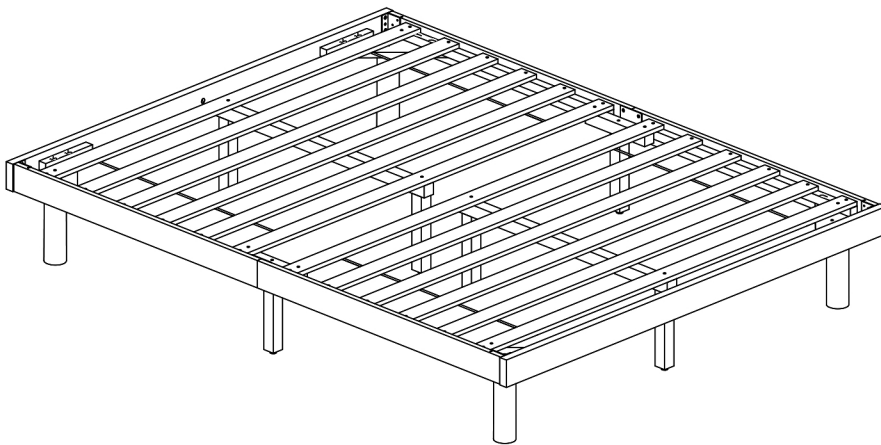

**Note: Do not assemble using power tools. This can cause the bolts to be overtightened**

## 2 Parts List

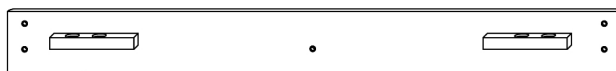

**A** Head / Footboard Panel x 2



**D**

Post x 4



**E**

Support Leg x 6

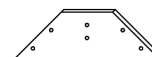

**F**

Support Panel x 4

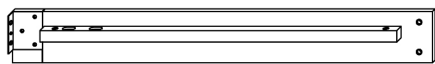

**B** Side Rail (Left Hand) x 2



**G** Long Support x 2

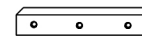

**H** Support Bar x 2



**C** Side Rail (Right Hand) x 2

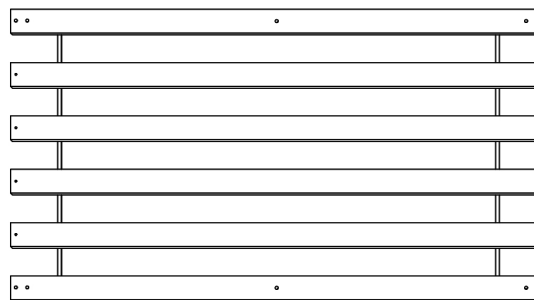

**J** Set of Bed Slats x 2

# 0082 S Full Bed

## Assembly Instructions

WI-0521

### 3 Hardware List

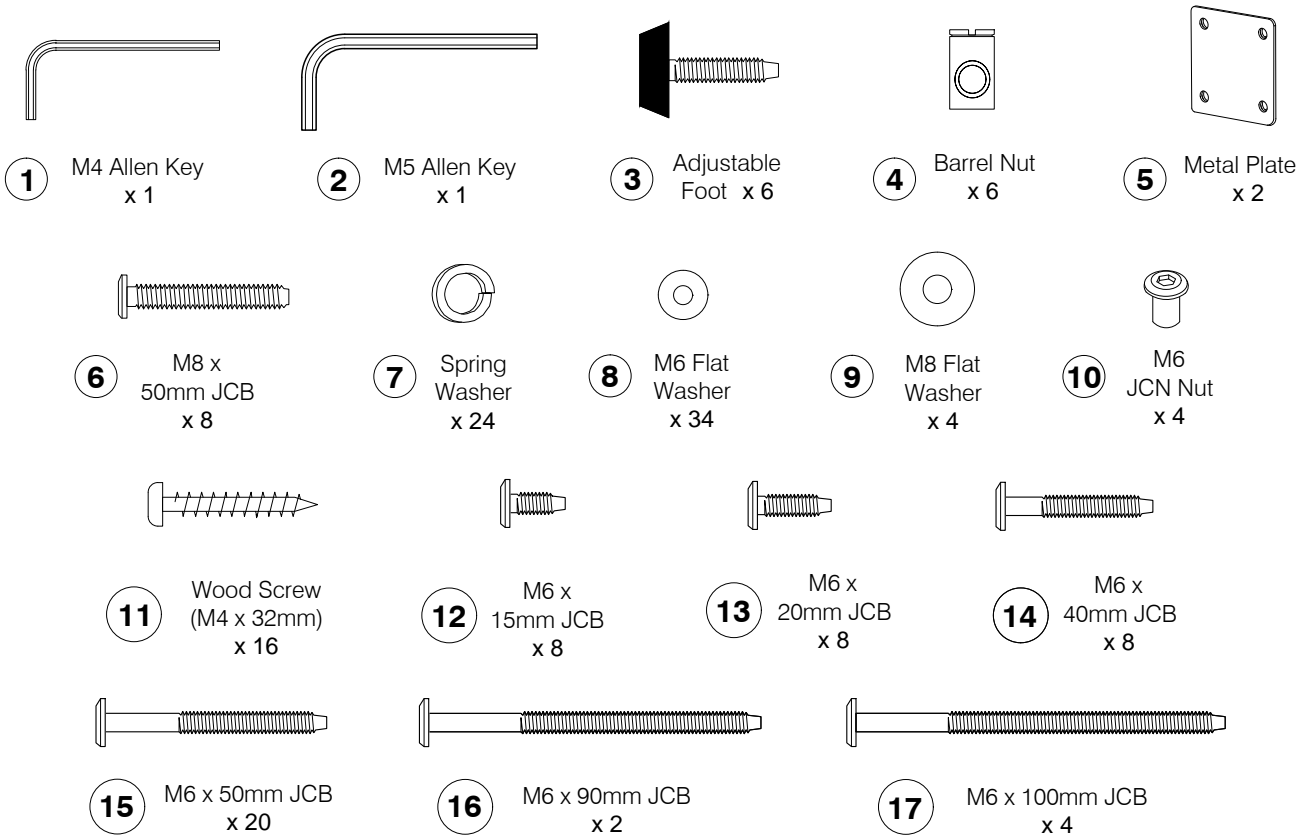

### 4 Fit the Adjustable foot to the bottom of the Support Leg (E).

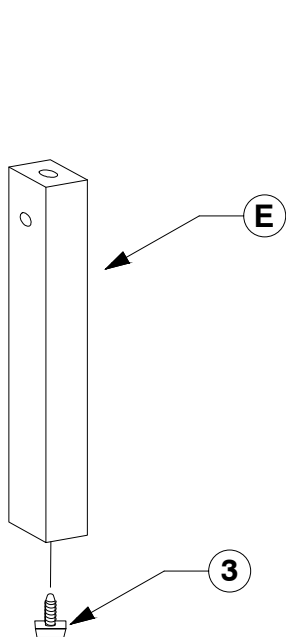

### 5 Fit the Support Bar (H) to the Support Leg (E).

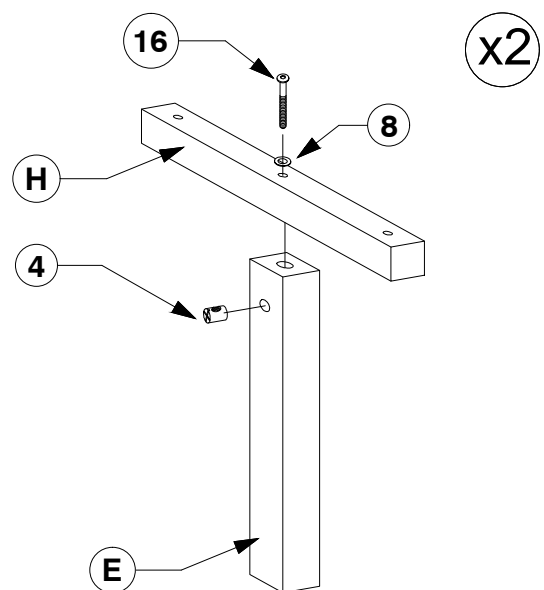

# 0082 S Full Bed

Assembly Instructions

WI-0521

- 6** Fit the Post (D) to the Support Panel (F).

x4

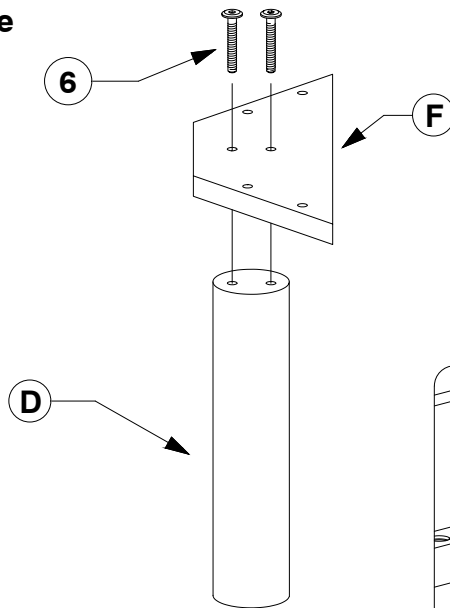

- 7** Fit the metal plate to the Side Rail (B & C).

x2

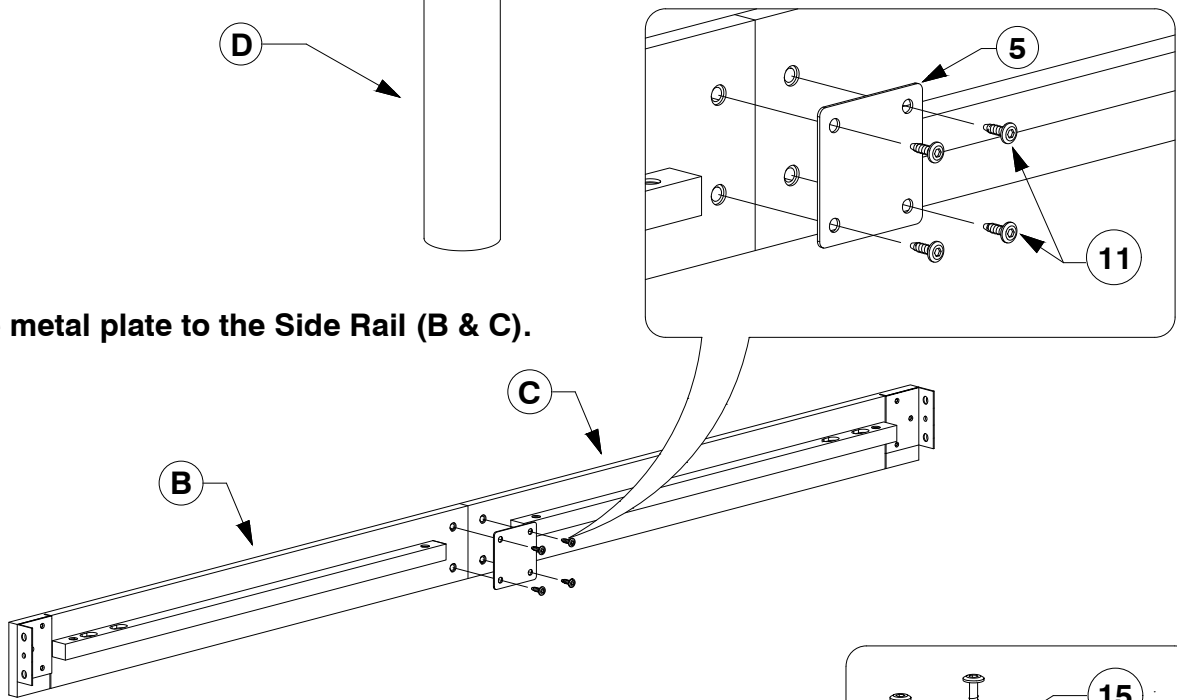

- 8** Assemble the Side Rail (B & C) to the Support Panel (F).

x2

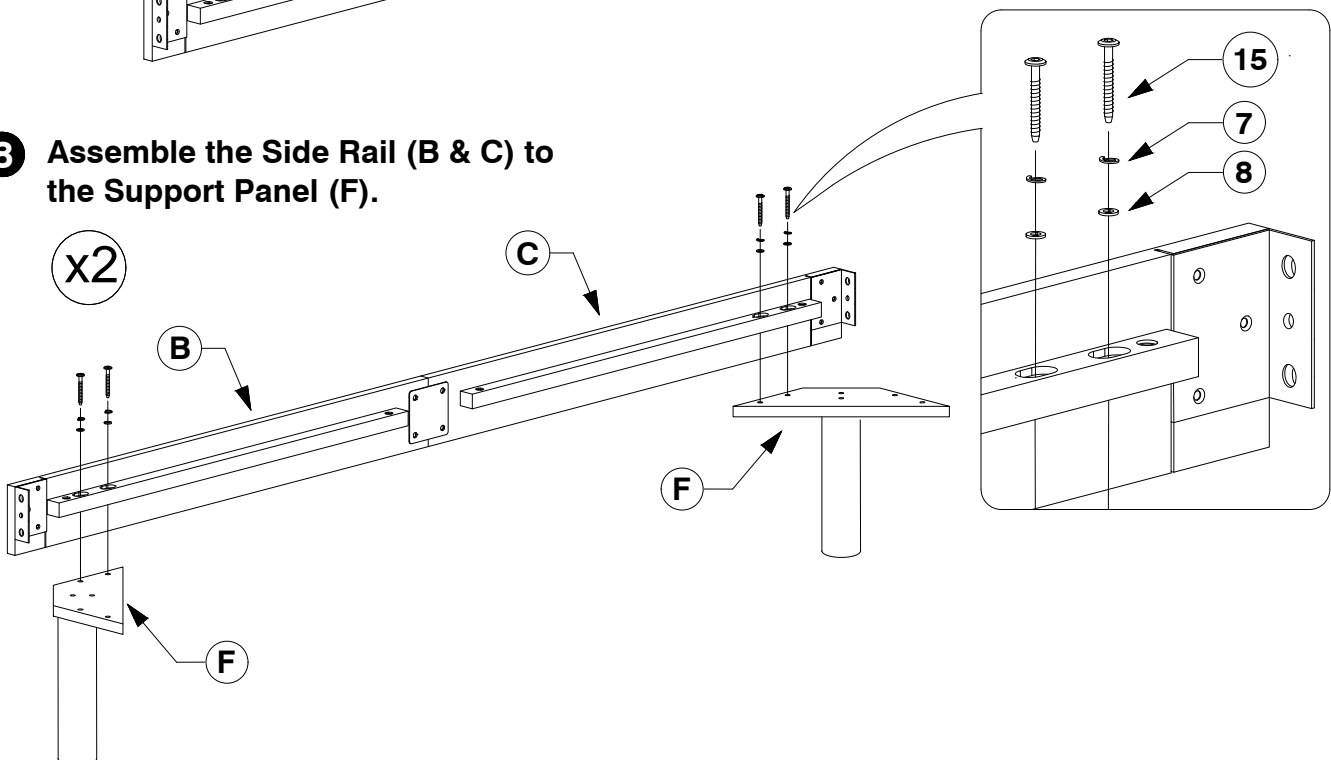

# 0082 S Full Bed

Assembly Instructions

WI-0521

- 9** Assemble the Side Rail (B & C) to the Head / Footboard (A).

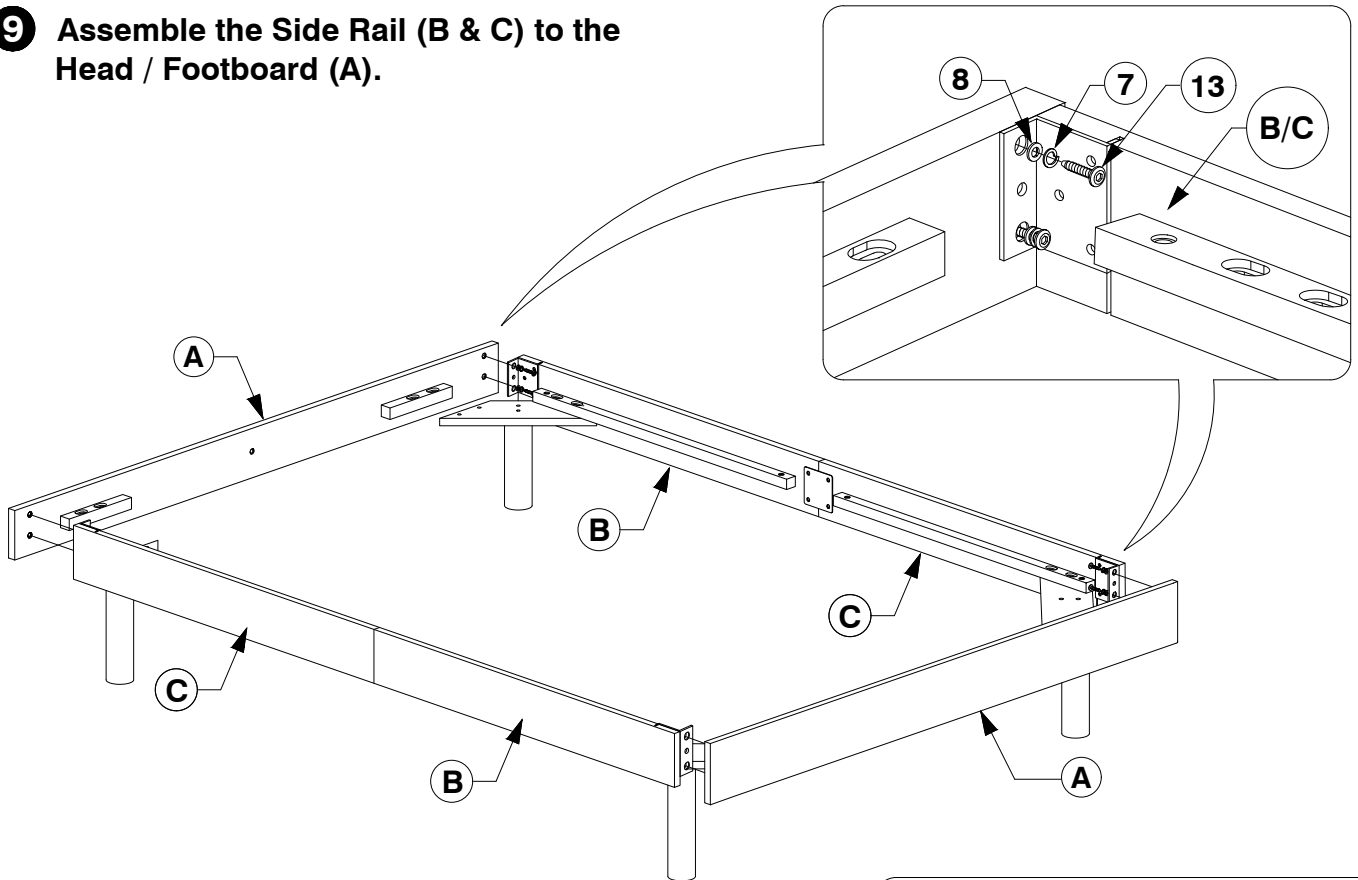

- 10** Bolt the Support Panel (F) to the Head / Footboard (A).

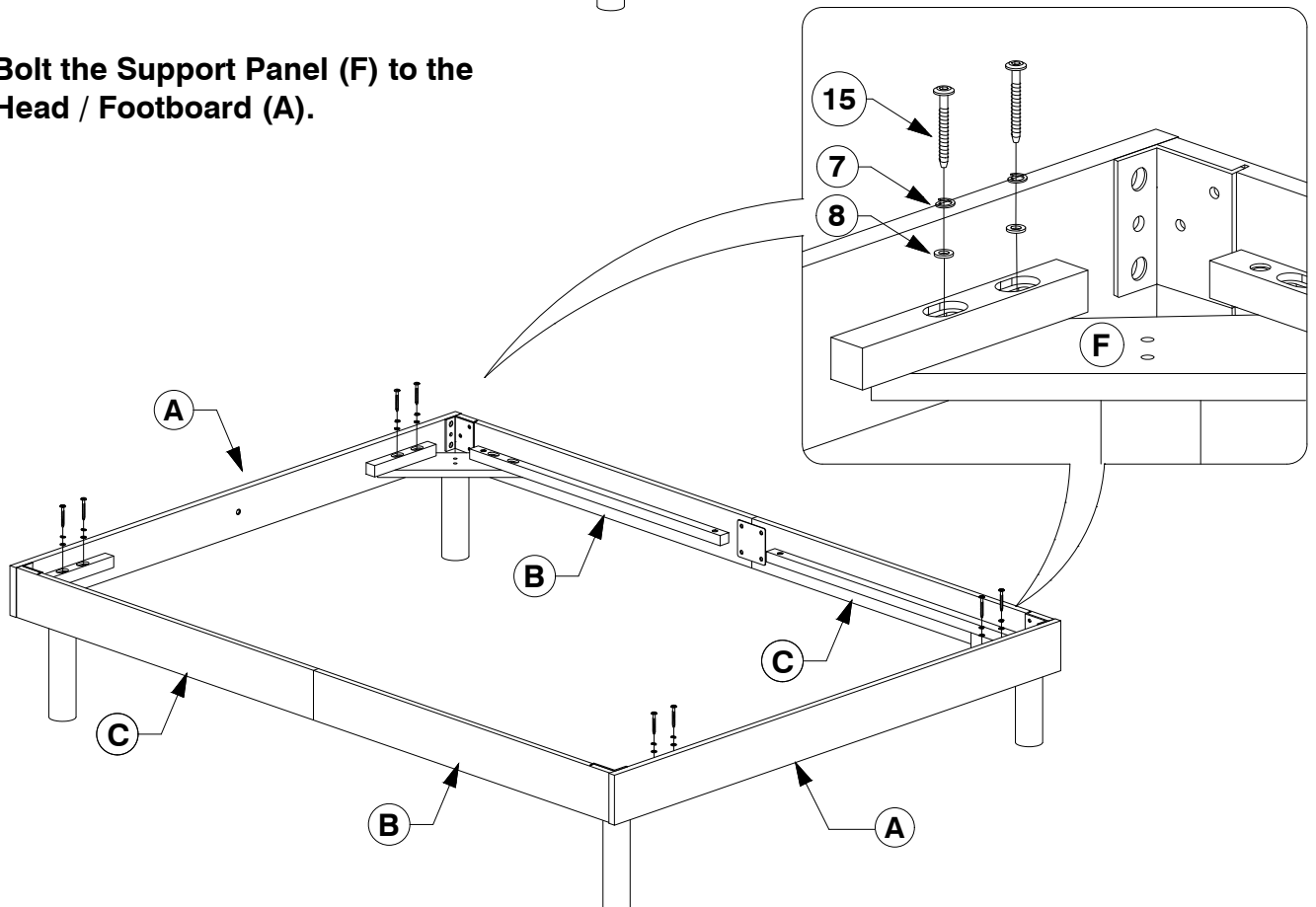

# 0082 S Full Bed

Assembly Instructions

WI-0521

- 11** Fix the Slats (J) to the Long Support (G) & Support Leg (E).

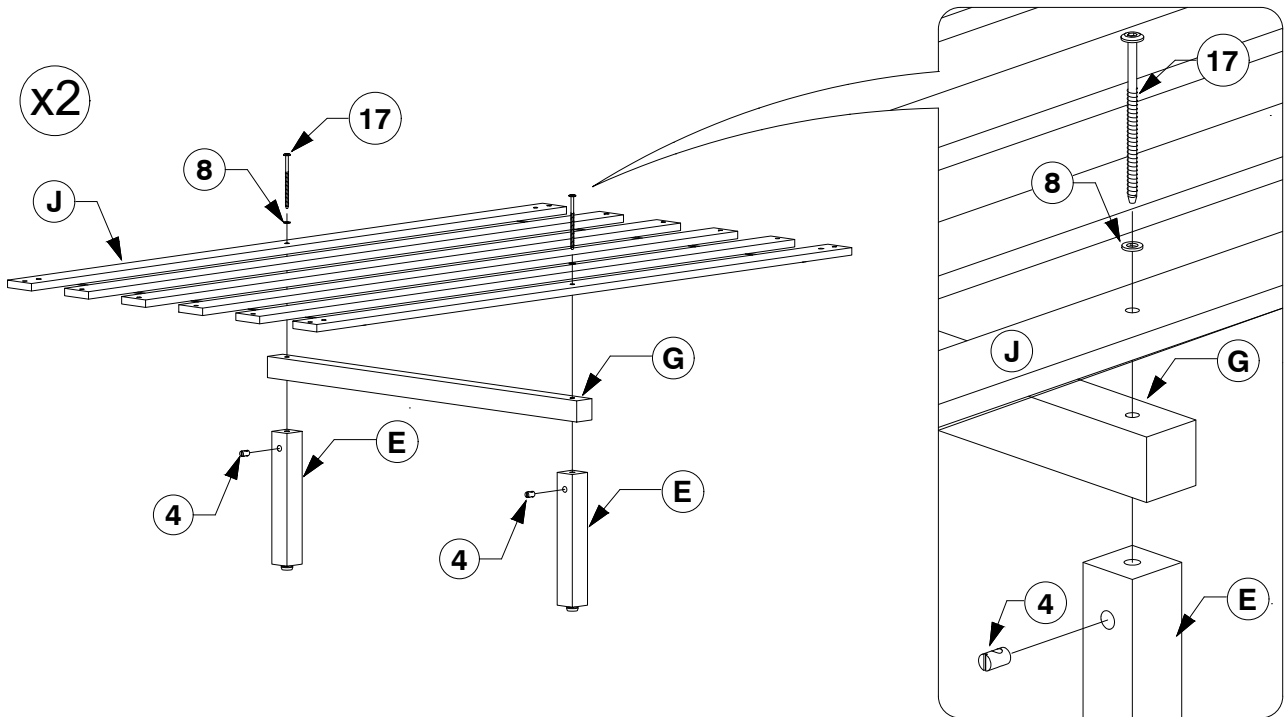

- 12** Bolt the Bed Slat (J) to the Side Rail (B & C).

