

0024 Full Bed

Assembly Instructions

WII-1219

1 Assembled View

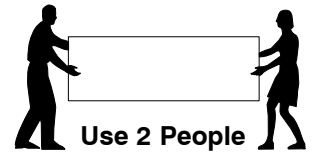
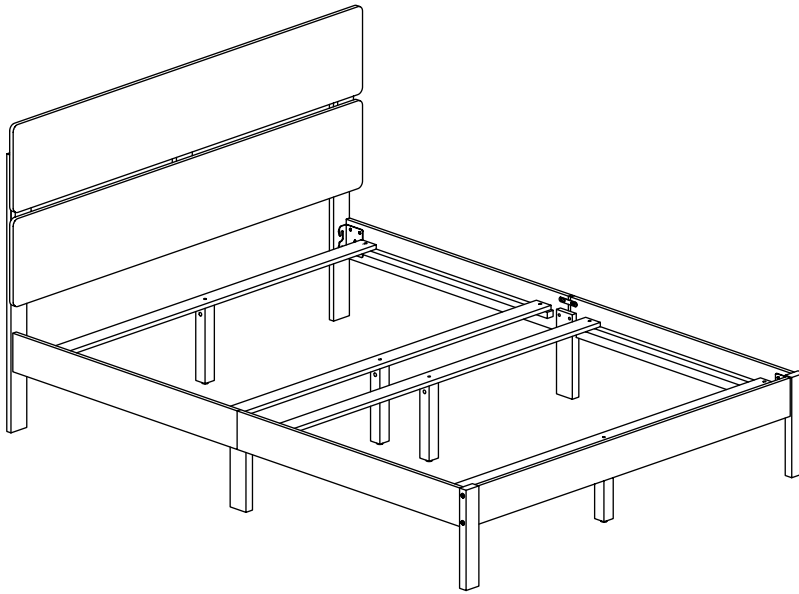

Note: Do not assemble using power tools. This can cause the bolts to be overtightened

2 Parts List

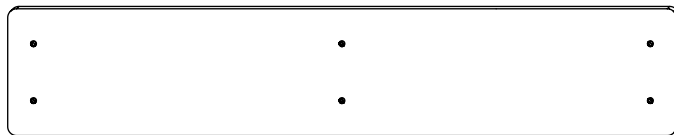

A Headboard Panel x 2

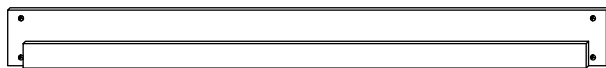

B Footboard Panel x 1

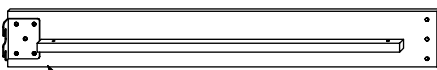

C Side Rail (Left Hand) x 2

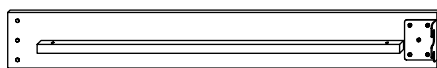

D Side Rail (Right Hand) x 2

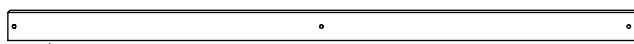

E Bed Slats x 4



F Headboard Support Bar x 3



G Center Support Leg x 2



H Support Leg x 4



J Headboard Post (Left Hand) x 1



K Headboard Post (Right Hand) x 1



L Footboard Post (Left Hand) x 1

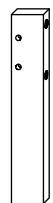

M Footboard Post (Right Hand) x 1

0024 Full Bed

Assembly Instructions

WII-1219

3 Hardware List



1 M6 x 90mm JCB
x 4

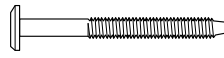

2 M6 x 60mm JCB
x 4



3 M6 x 40mm JCB
x 8

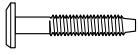

4 M6 x 35mm JCB
x 4



5 M6 x 30mm JCB
x 20



6 M6 x 20mm JCB
x 8



7 M6 x 15mm JCB
x 4



8 Barrel
Nut x 8



9 Wood Dowel
(M10 x 40mm) x 2



10 Spring
Washer x 24



11 Flat Washer
x 24



12 Allen Key
x 1

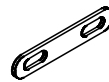

13 Bracket
(2003) x 2

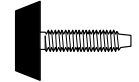

14 Adjustable
Foot x 4

4 Assembled the Support Legs (H) to the Bed Slat (E).

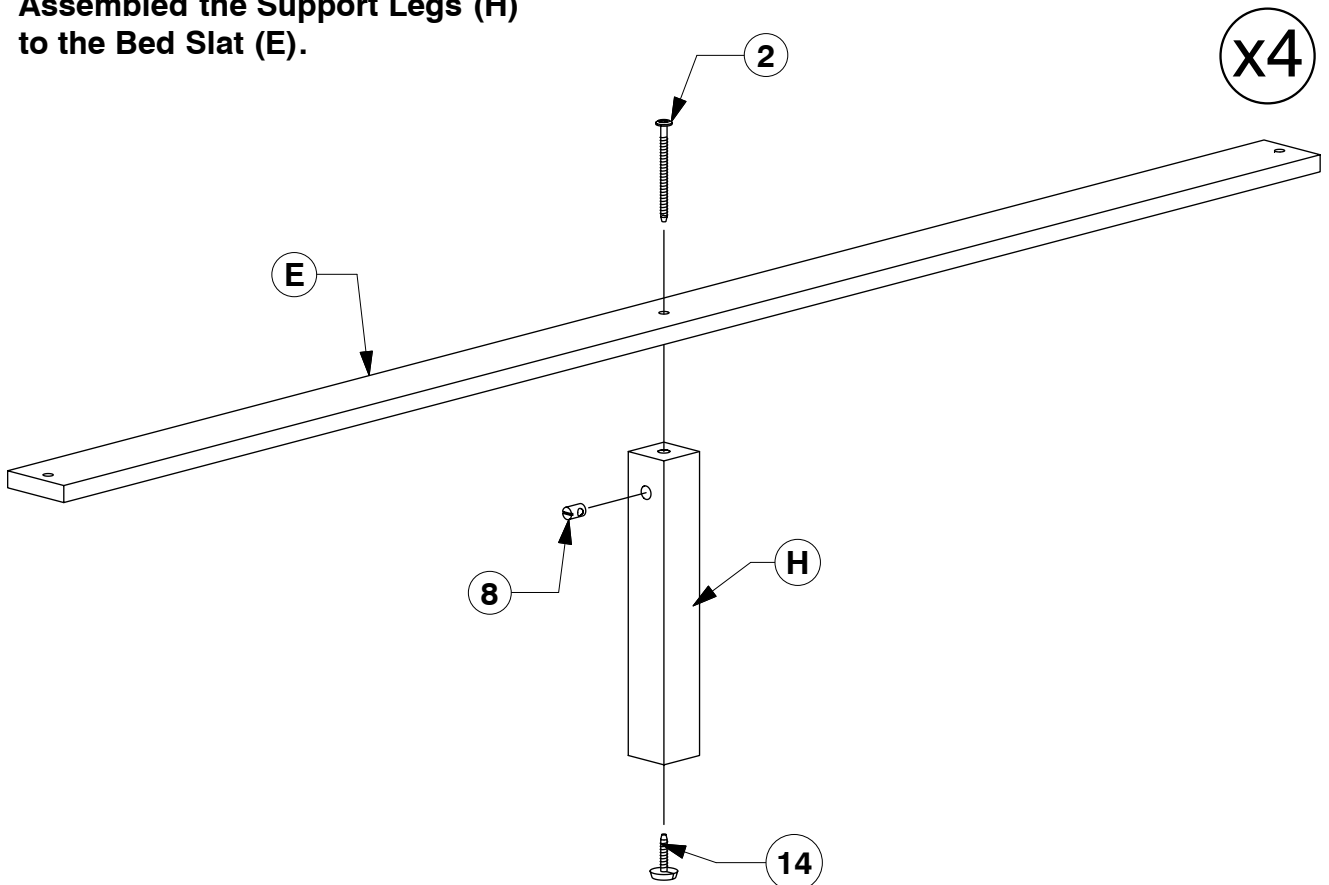

0024 Full Bed

Assembly Instructions

WII-1219

- 5** Fit the Headboard Support Bar (F) to the Headboard Panel (A).

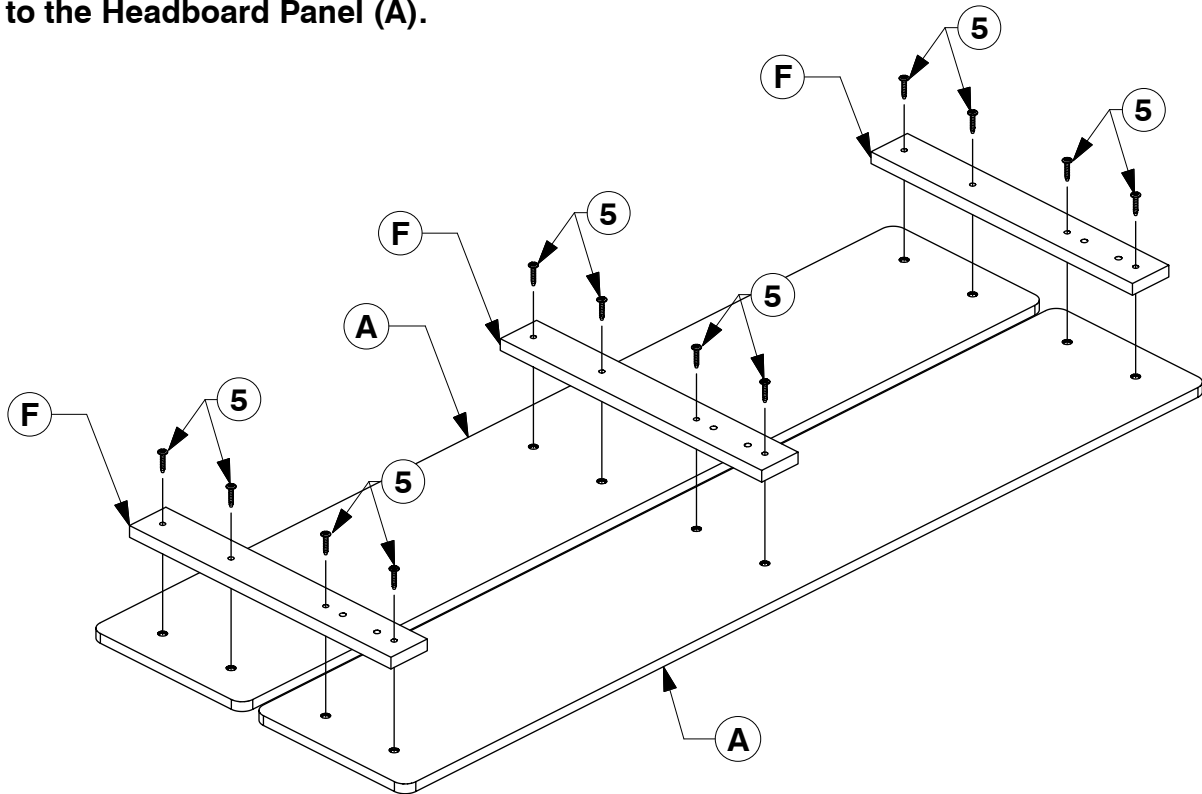

- 6** Fit the Headboard Post (J & K) to the Headboard Panel (A).

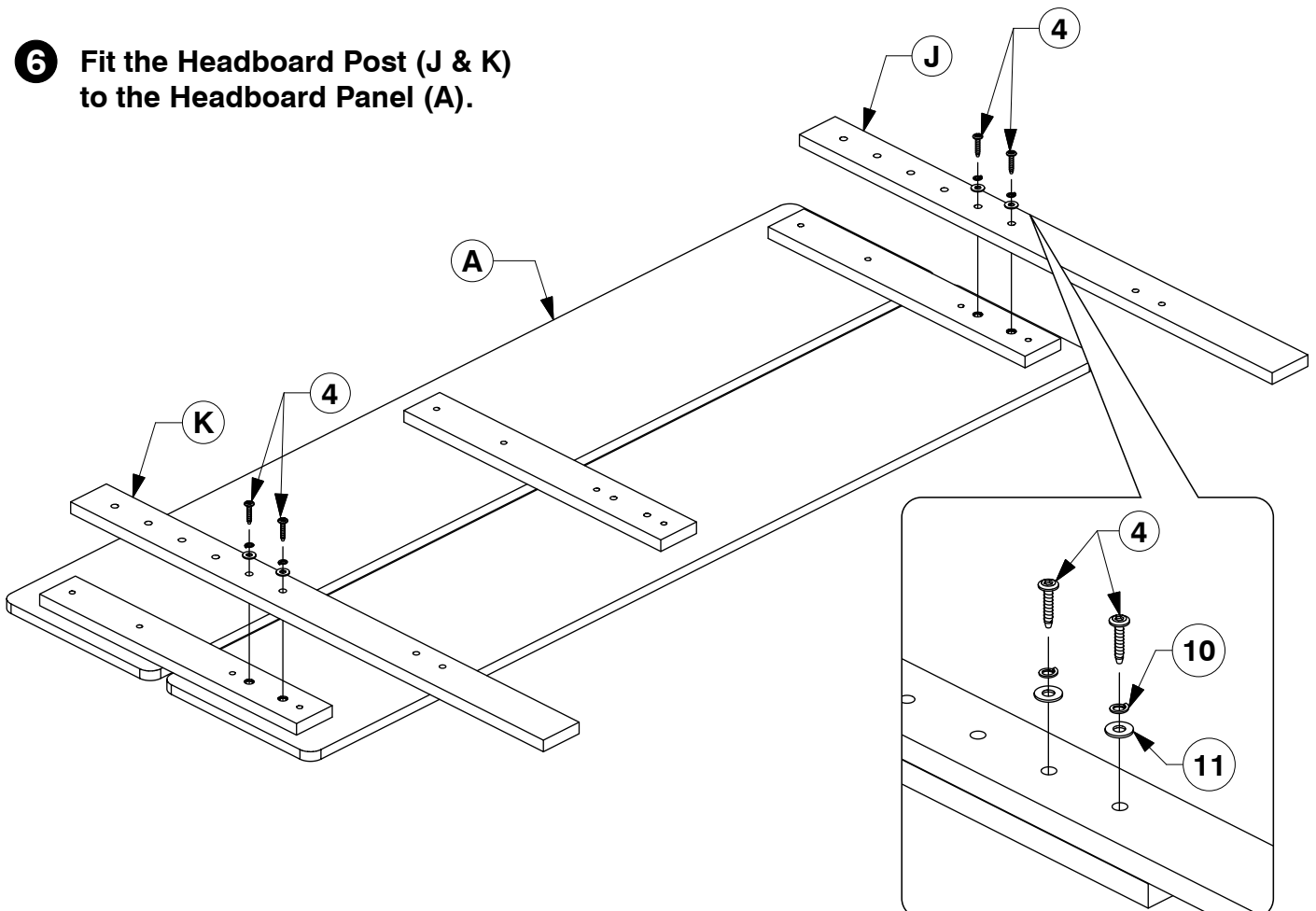

0024 Full Bed

Assembly Instructions

WII-1219

- 7** Assemble the Footboard Post (L & M) to the Footboard Panel (B).

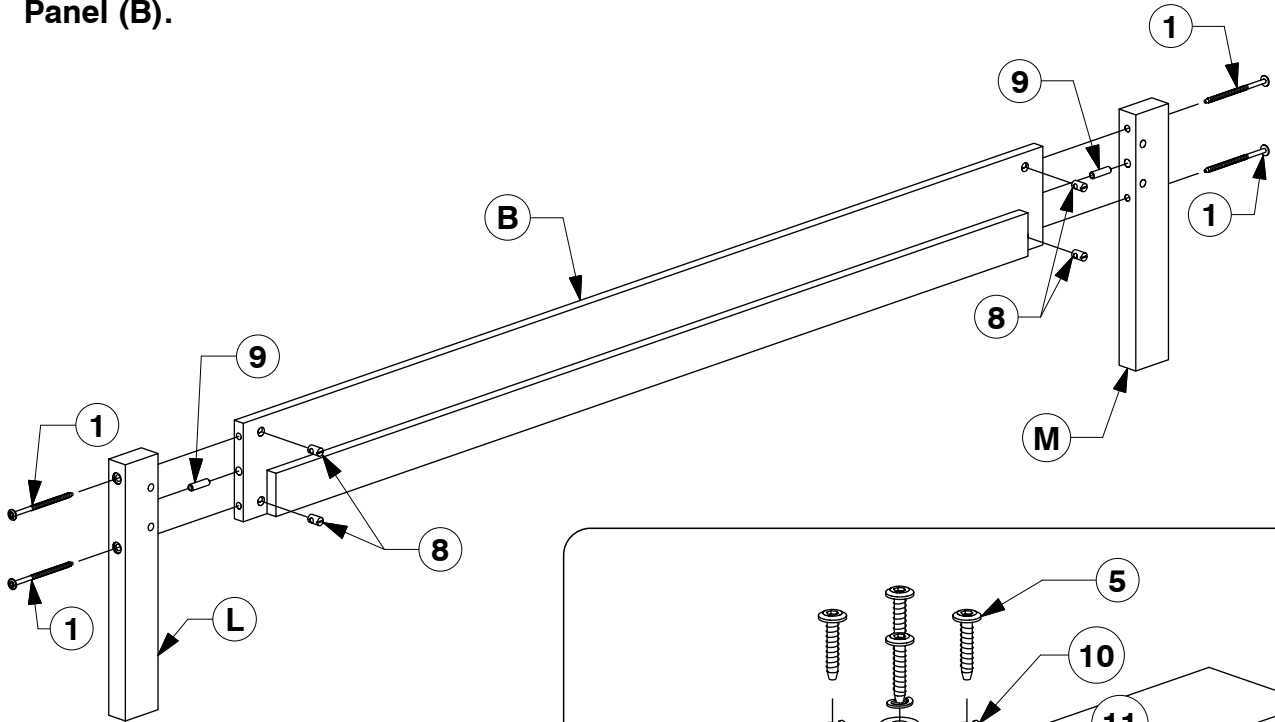

- 8** Fit the Center Support Leg (G).

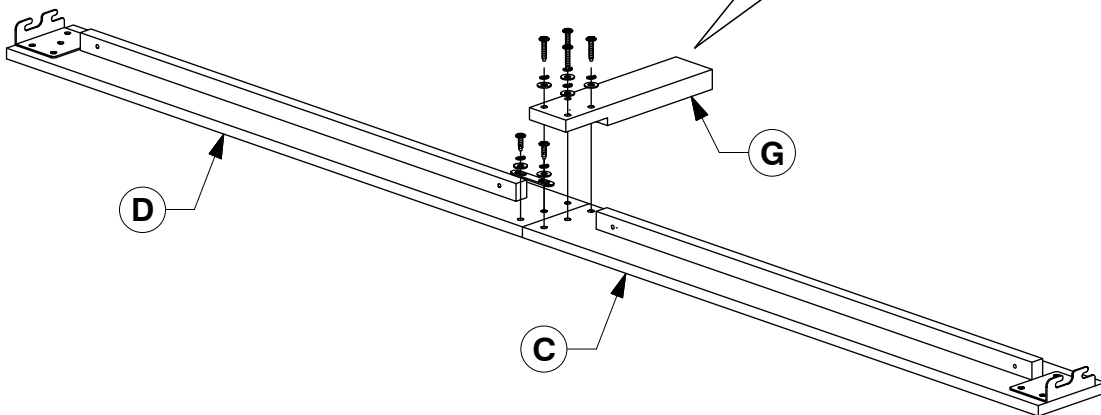
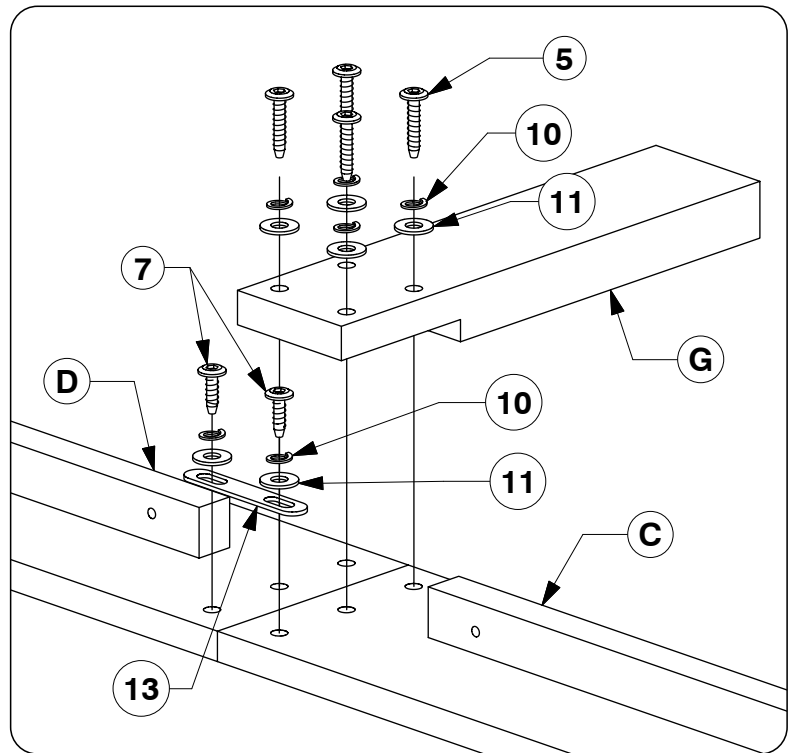

0024 Full Bed

Assembly Instructions

WII-1219

9 Assemble the Side Rail (C & D) to the Post.

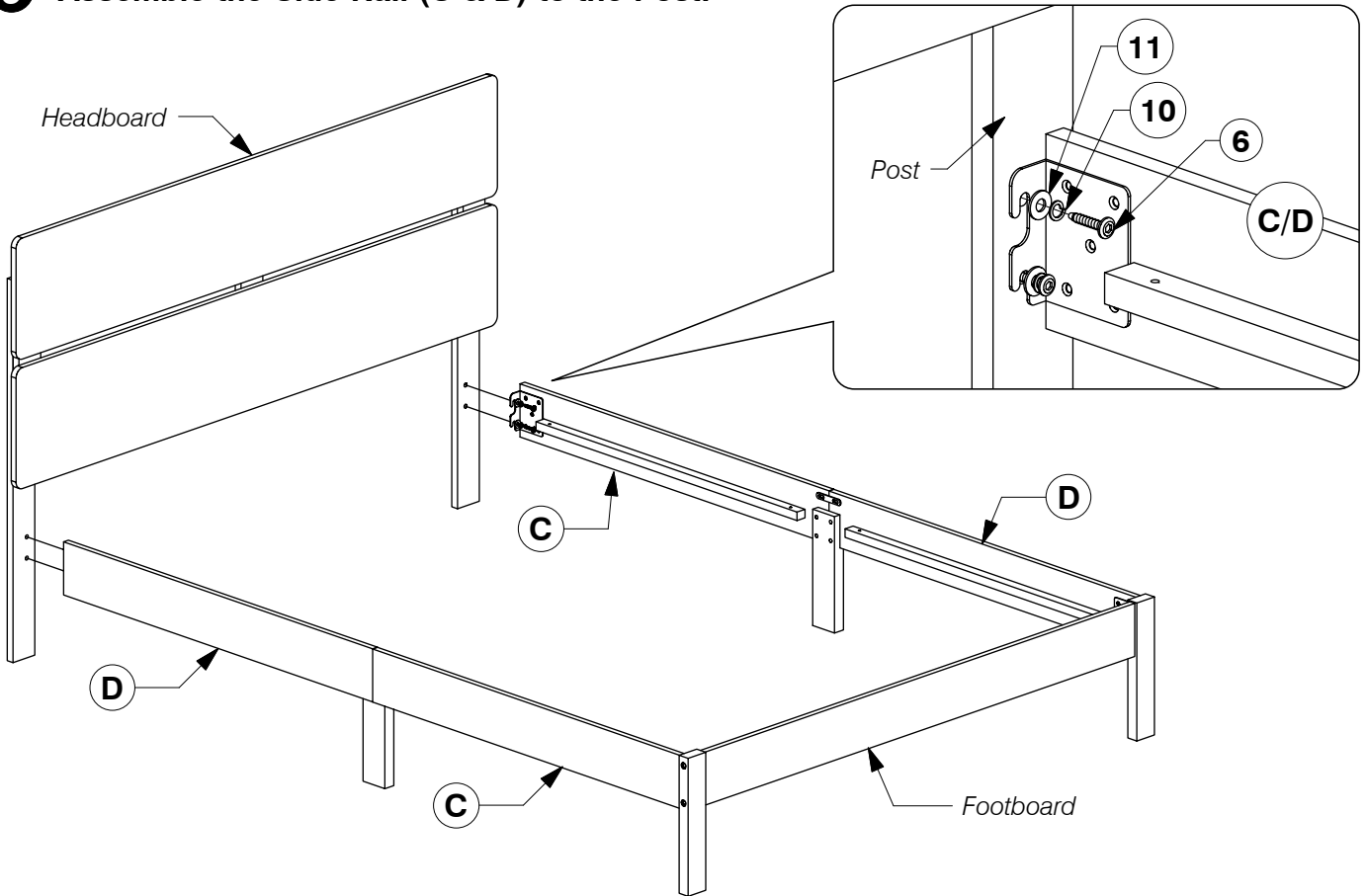

10 Bolt the Bed Slats (E) to the Side Rail (C & D).

