

# 0018 Queen Bed

## Assembly Instructions

W11-0919

### 1 Assembled View

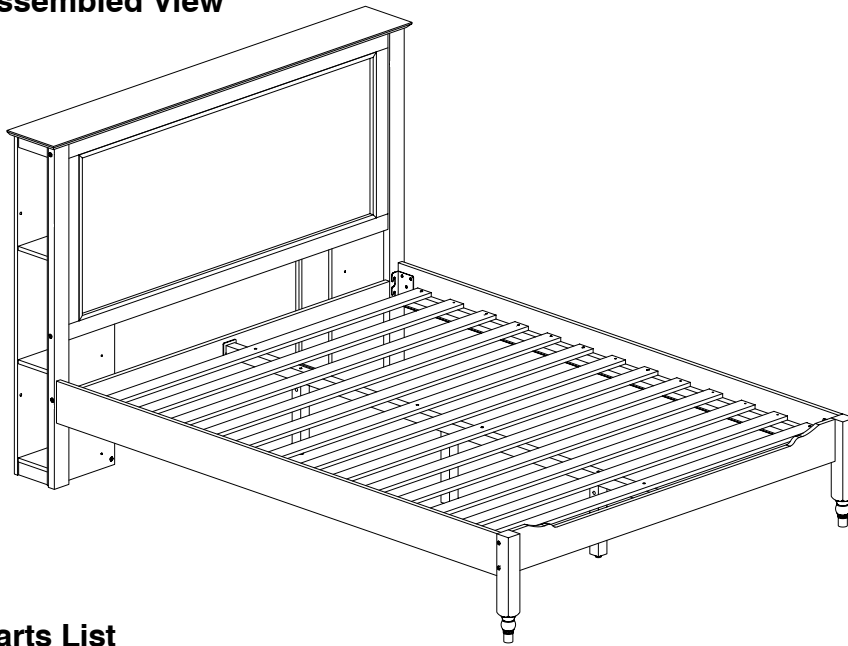

**Note:** Do not assemble using power tools. This can cause the bolts to be overtightened

### 2 Parts List

#### Parts in Box A:

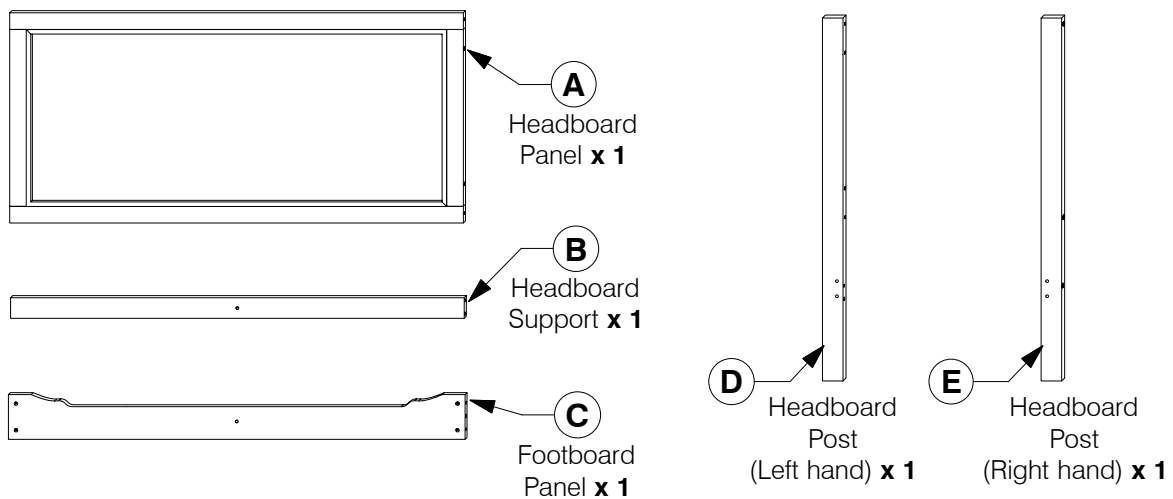

#### Parts in Box B:

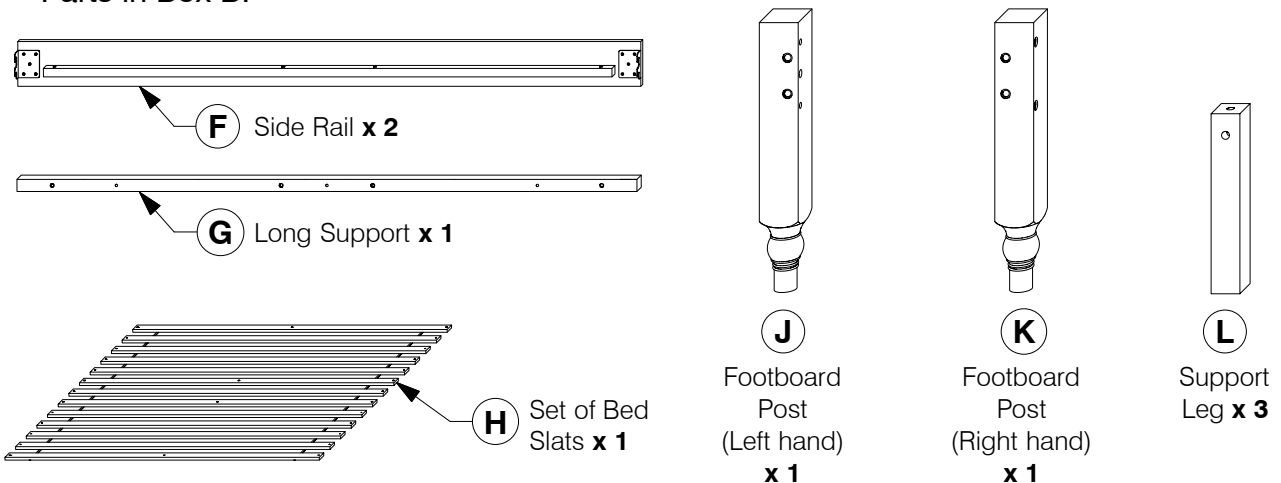

# 0018 Queen Bed

## Assembly Instructions

WII-0919

### 2 Parts List

Parts in Box C:

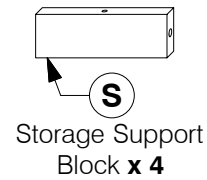
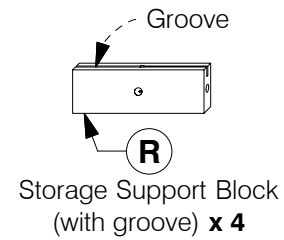
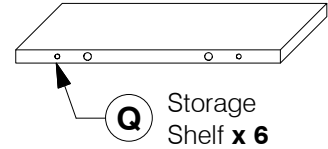
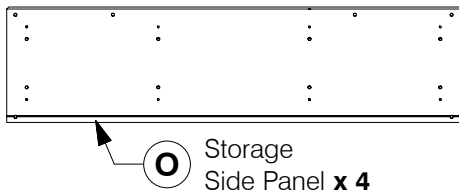
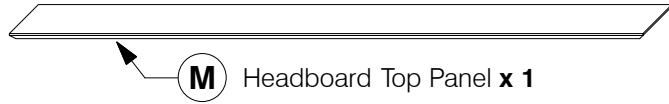

### 3 Hardware List

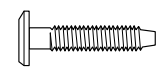
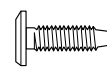
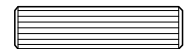
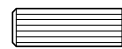
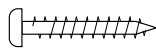
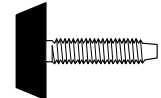
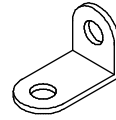
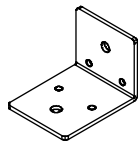

# 0018 Queen Bed

## Assembly Instructions

WII-0919

### 4 Assemble the Support Leg (L) to the Long Support (G).

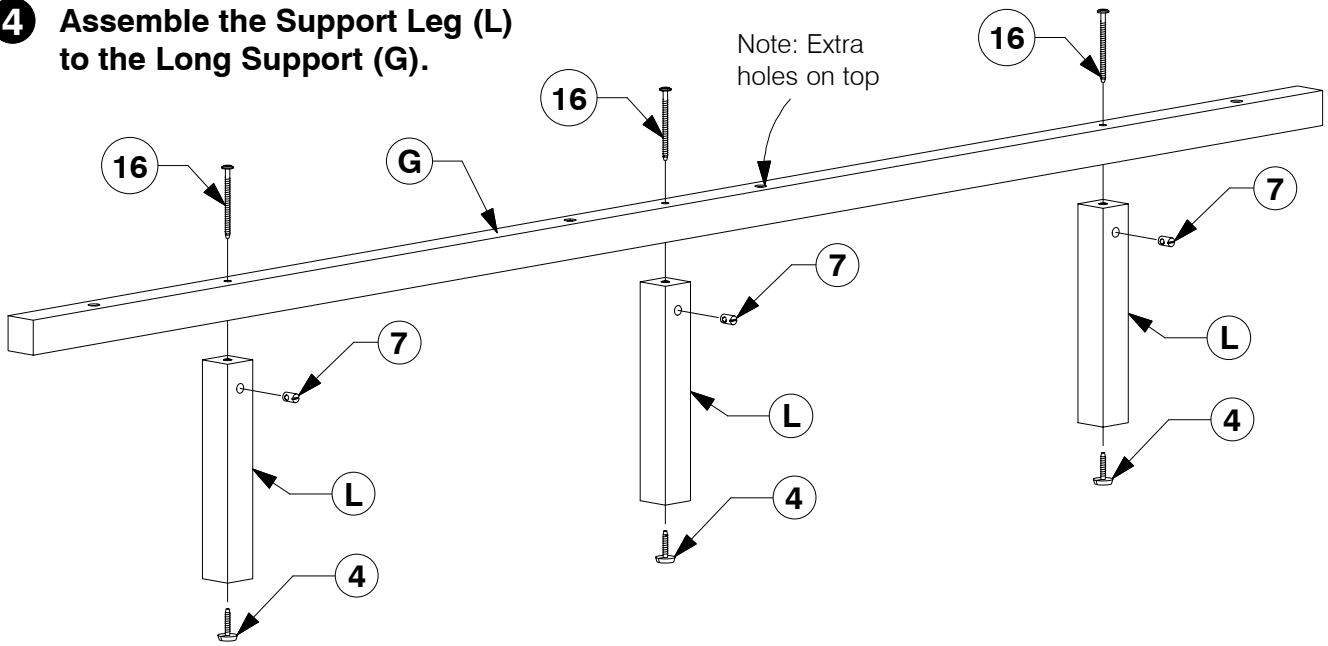

### 5 Fit the Center Rail Bracket to the Footboard Panel (C).

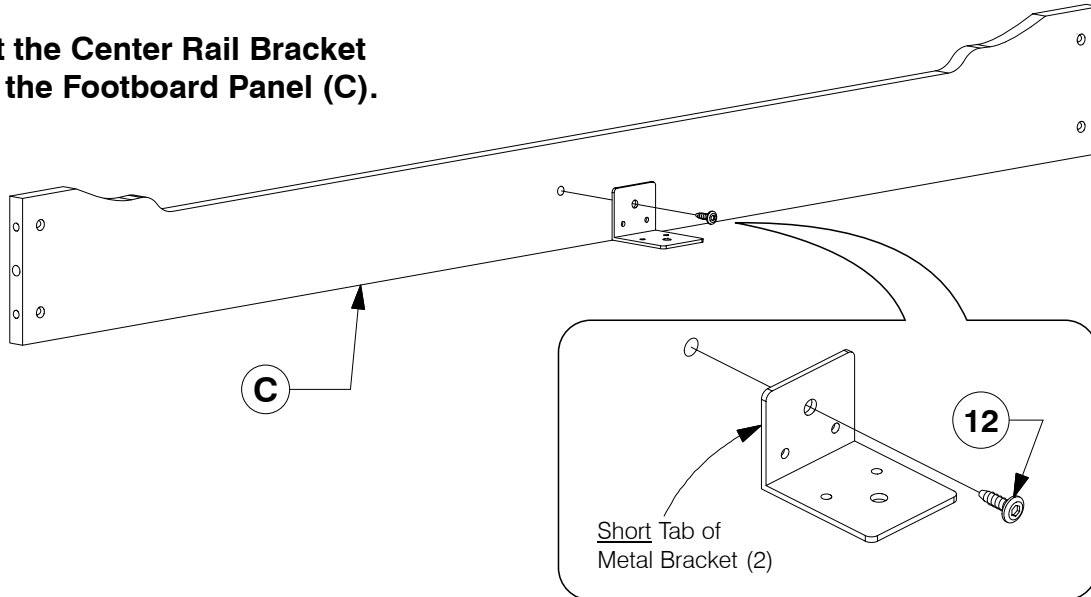

### 6 Assemble the Footboard Post (J & K) to the Footboard Panel (C).

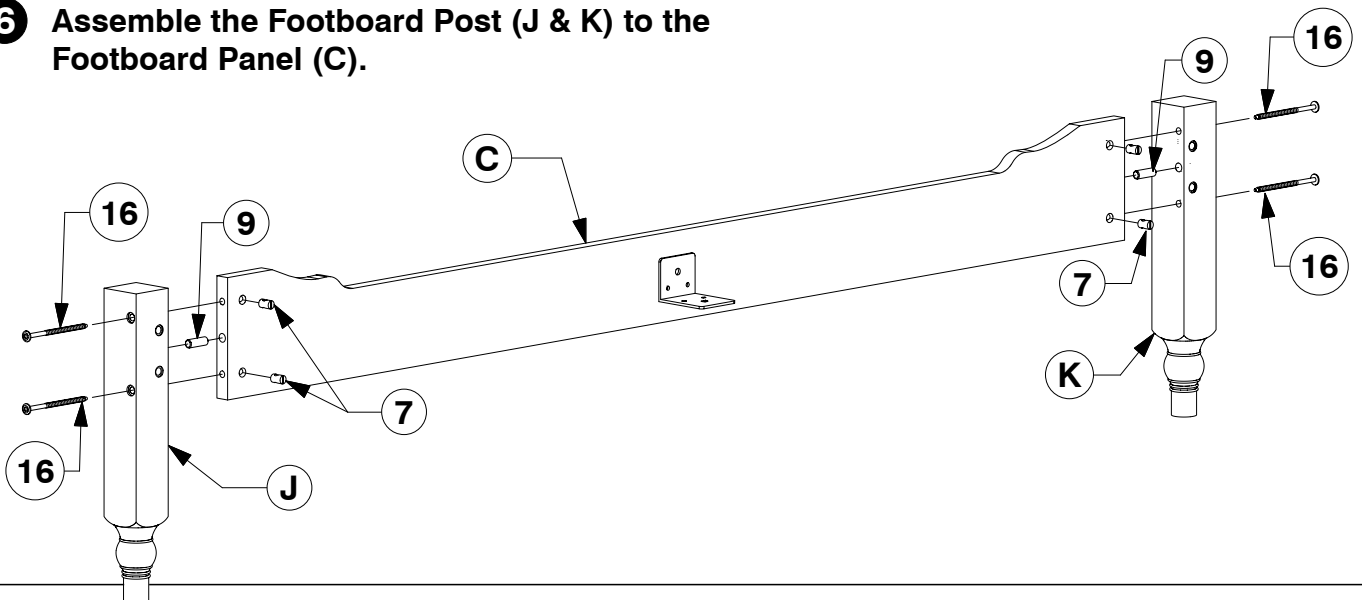

# 0018 Queen Bed

## Assembly Instructions

WII-0919

- 7** Fit the Center Rail Bracket to the Headboard Support (B).

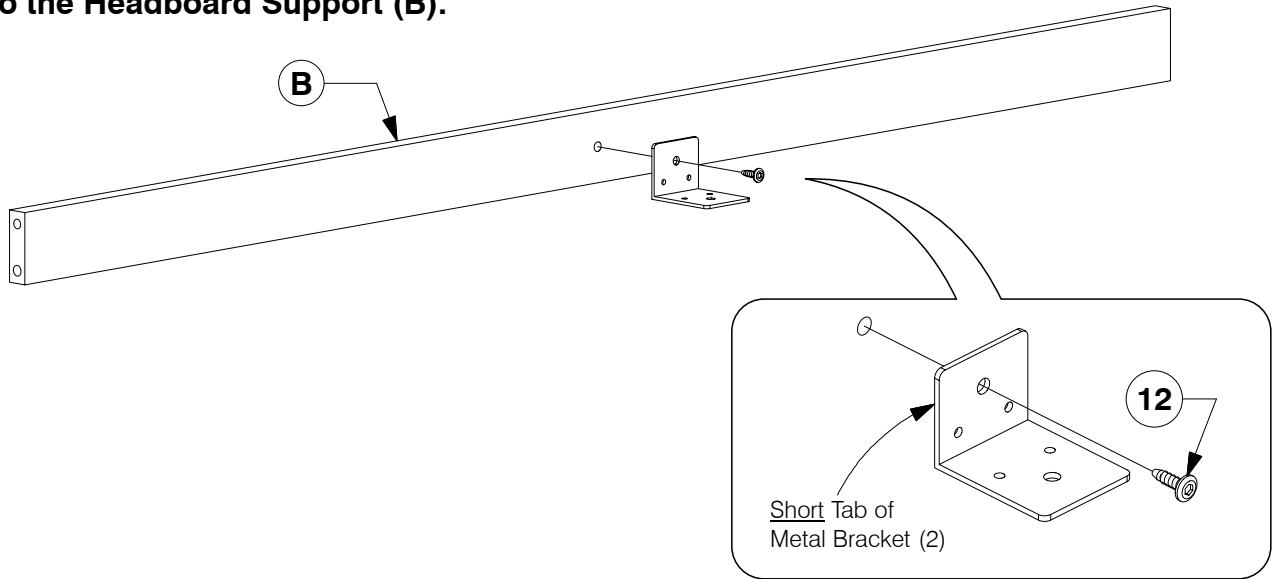

- 8** Assemble the Headboard Post (D & E) to the Headboard Panel (A) & Headboard Support (B).

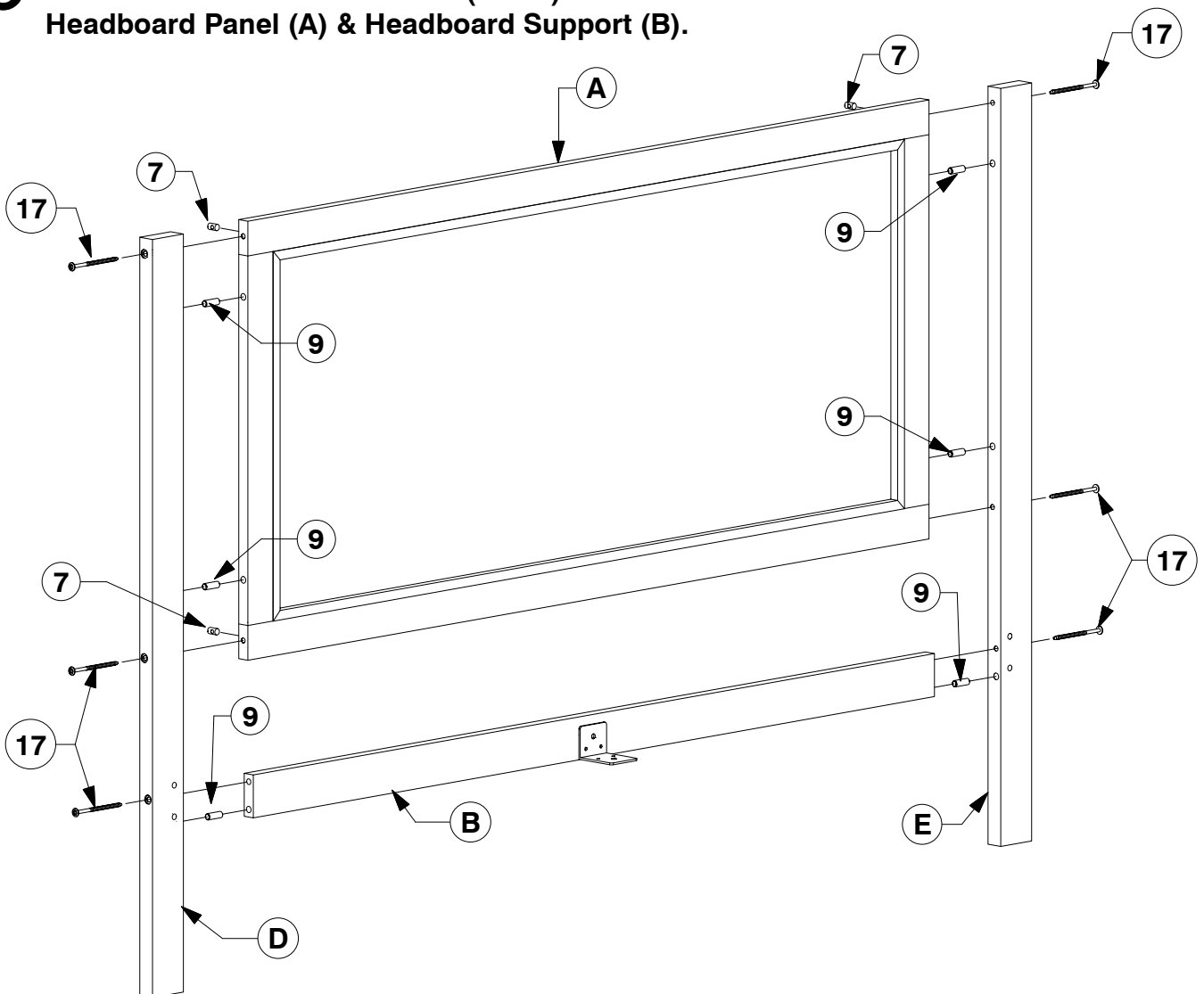

# 0018 Queen Bed

## Assembly Instructions

WII-0919

- 9** Assemble the Side Rail (F) to the Headboard & Footboard Panel (A & C).

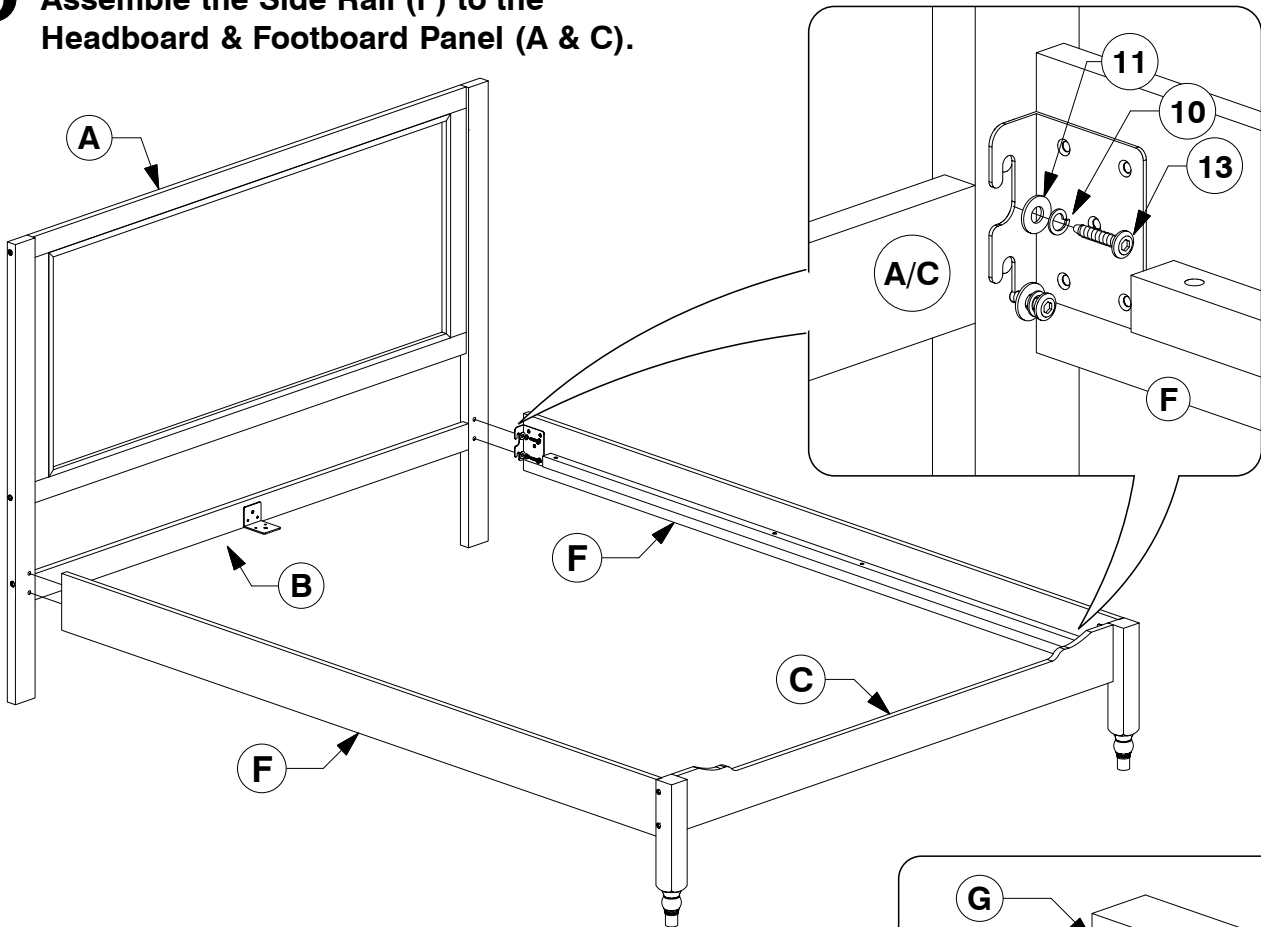

- 10** Bolt the Long Support (G) to the Center Rail Brackets on the Headboard Support (B) and Footboard Panel (C).

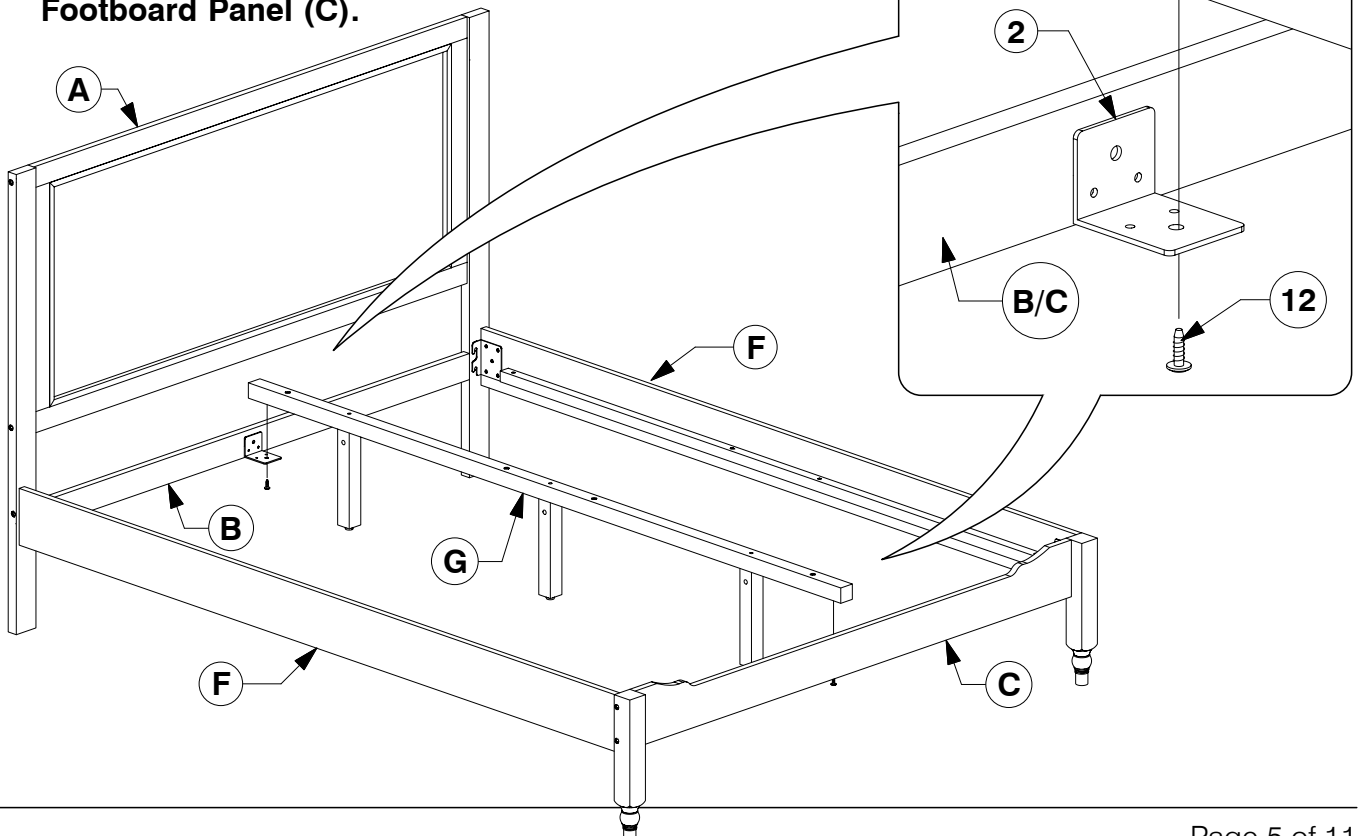

# 0018 Queen Bed

## Assembly Instructions

W11-0919

- 11** Bolt & screw the Bed Slats (H) to the Side Rail (F).

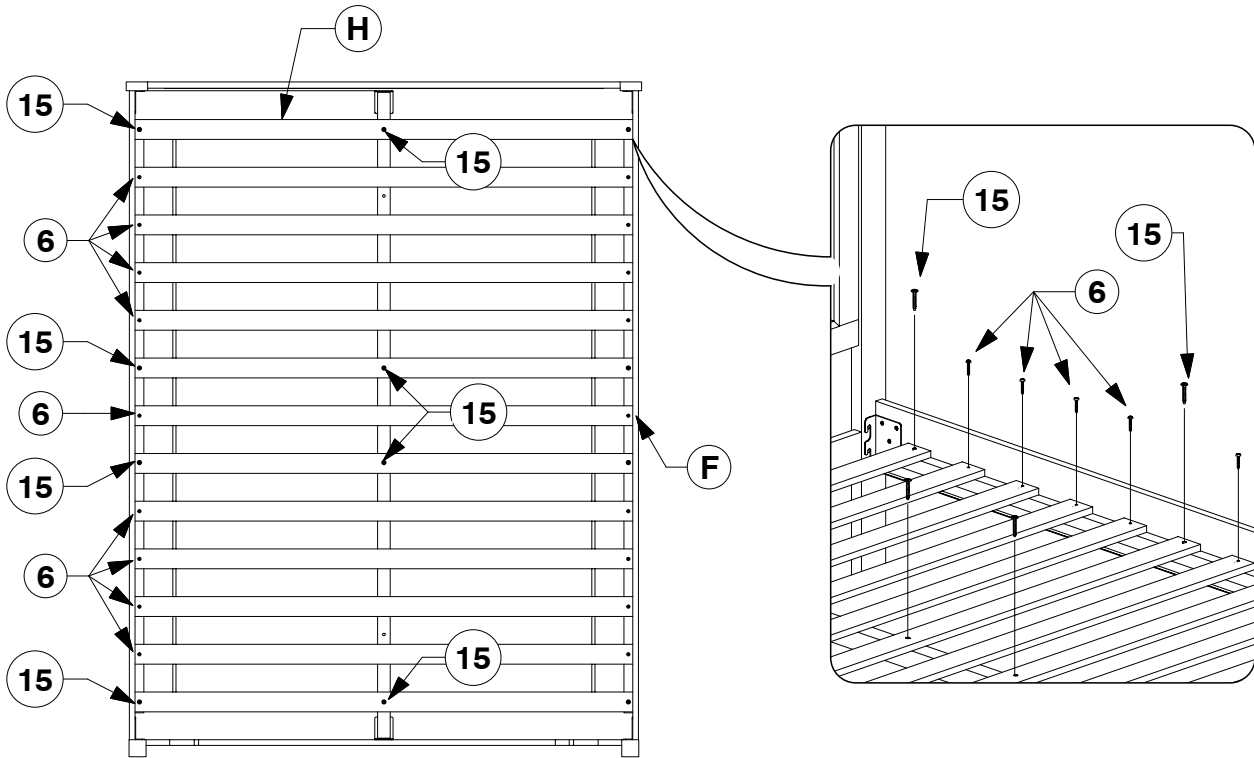

- 12** Tap the Wood Dowels (8) to the Storage Shelf (Q).

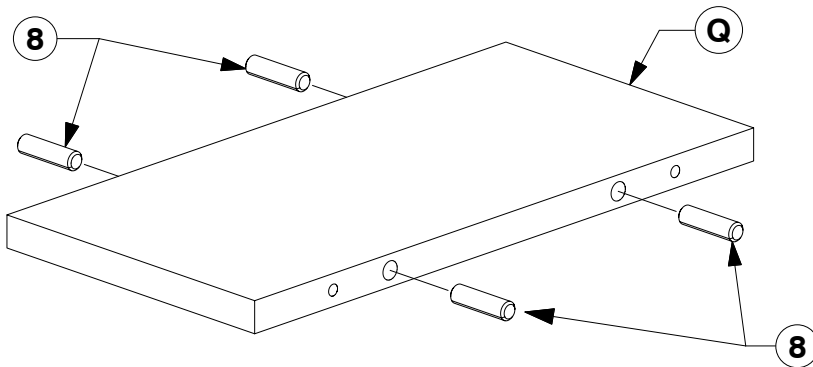

# 0018 Queen Bed

## Assembly Instructions

WII-0919

- 13** Fit the Storage Shelf (Q) to the Storage Side Panel (O).

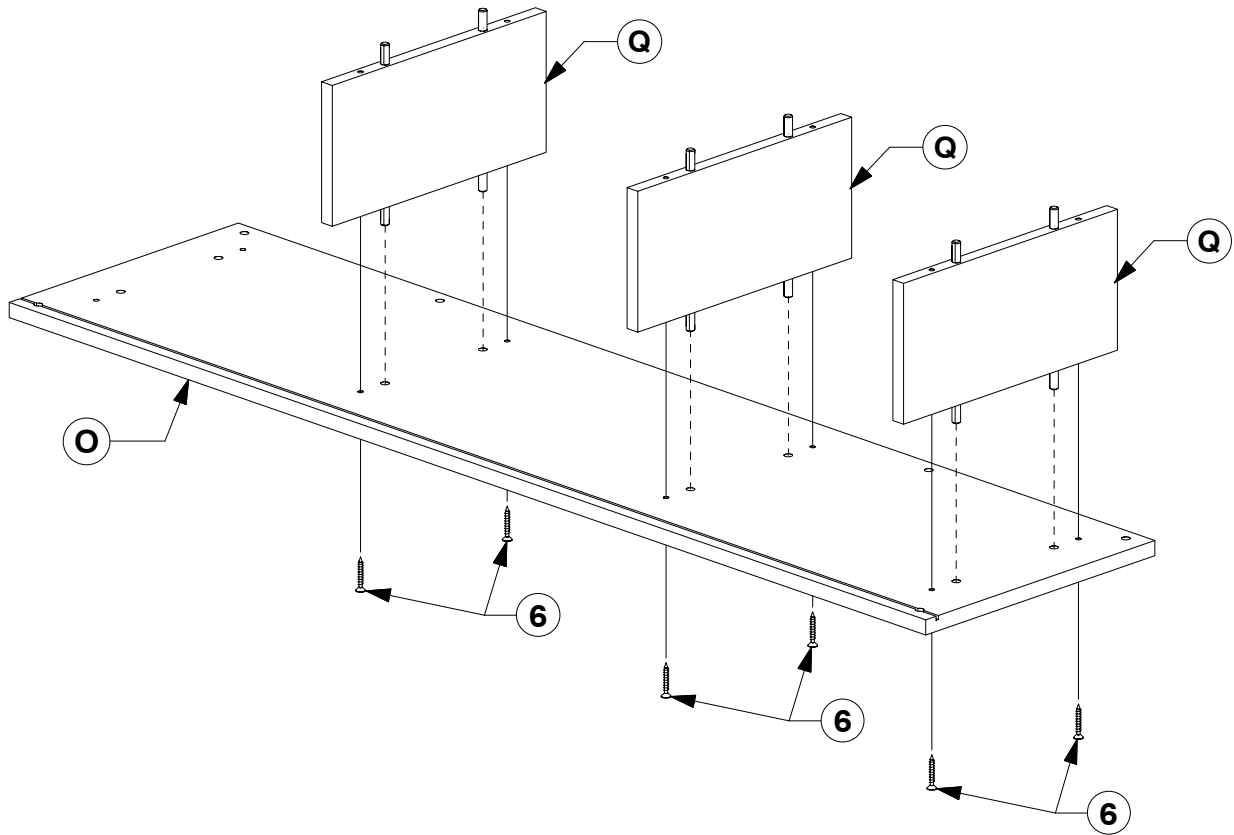

- 14** Fit the Storage Support Block (R & S) to the Storage Side Panel (O).

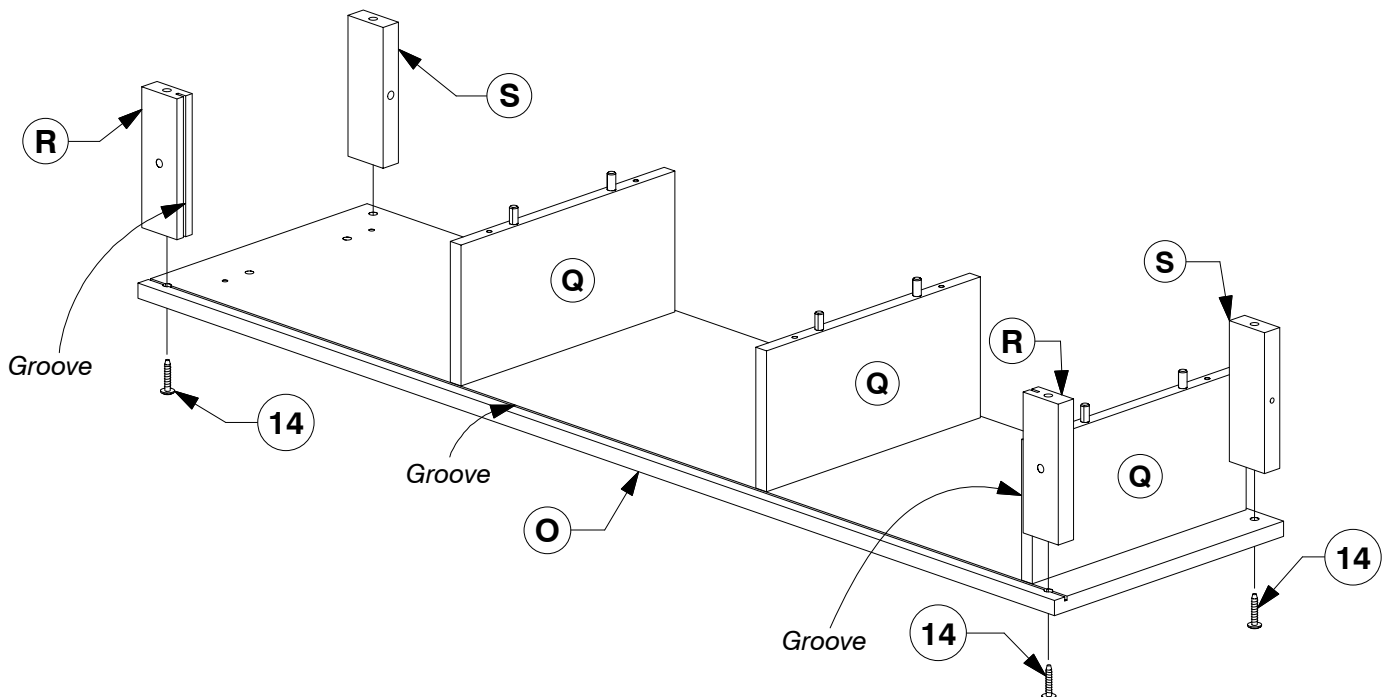

# 0018 Queen Bed

## Assembly Instructions

W11-0919

- 15** Slide the Storage Panel (P) into the groove.

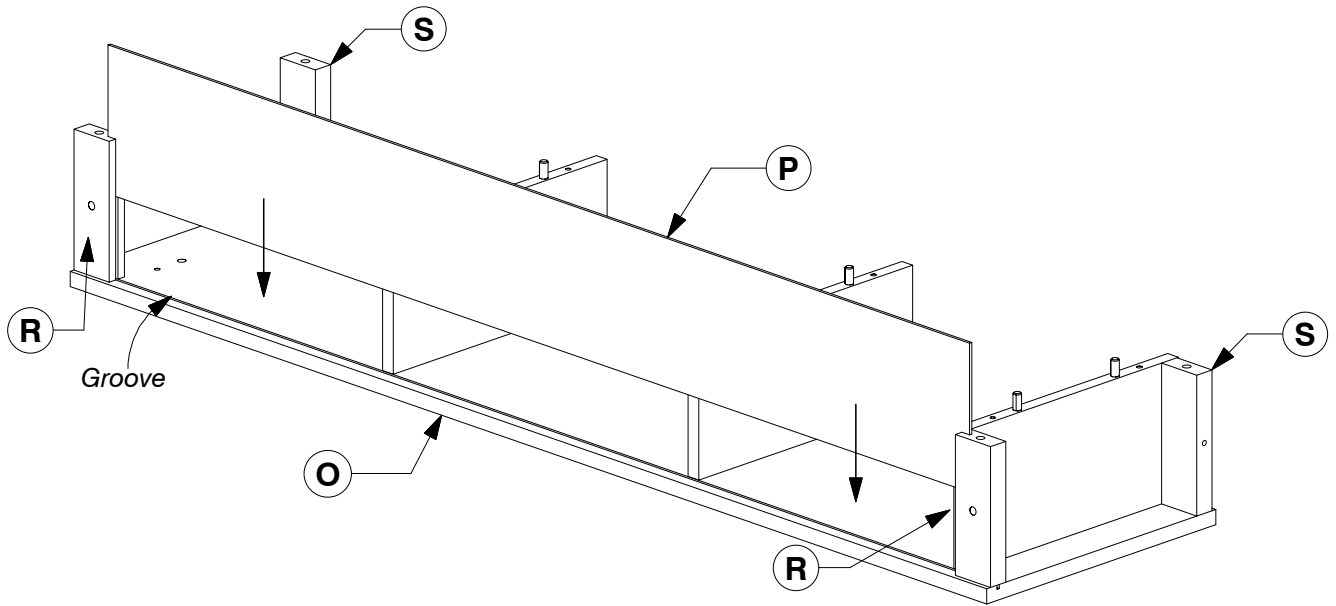

- 16** Fit the Storage Side Panel (O) in place.

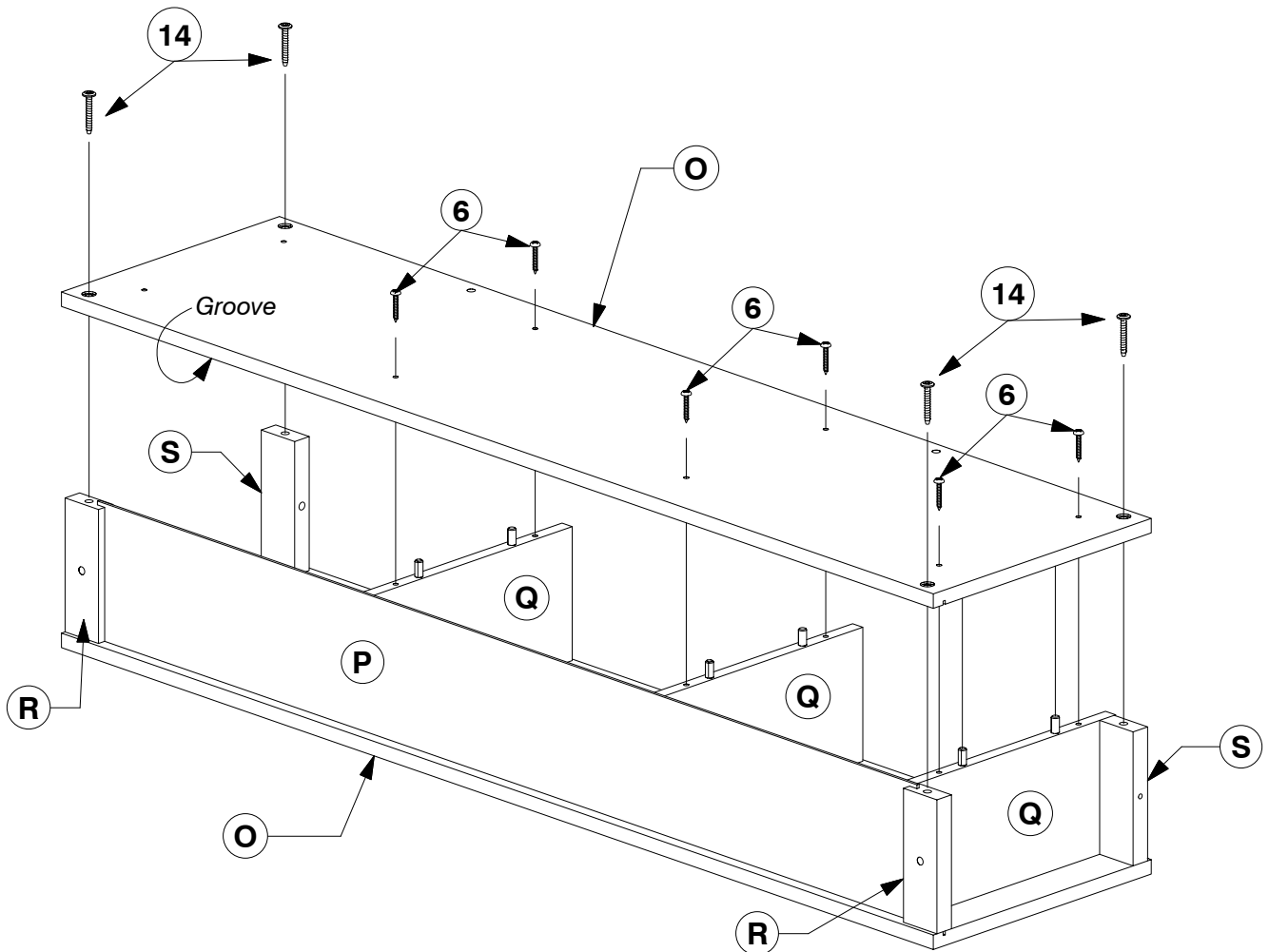



# 0018 Queen Bed

## Assembly Instructions

W11-0919

### 17 Attach the assembled Storage Box to the Headboard Post (D & E).

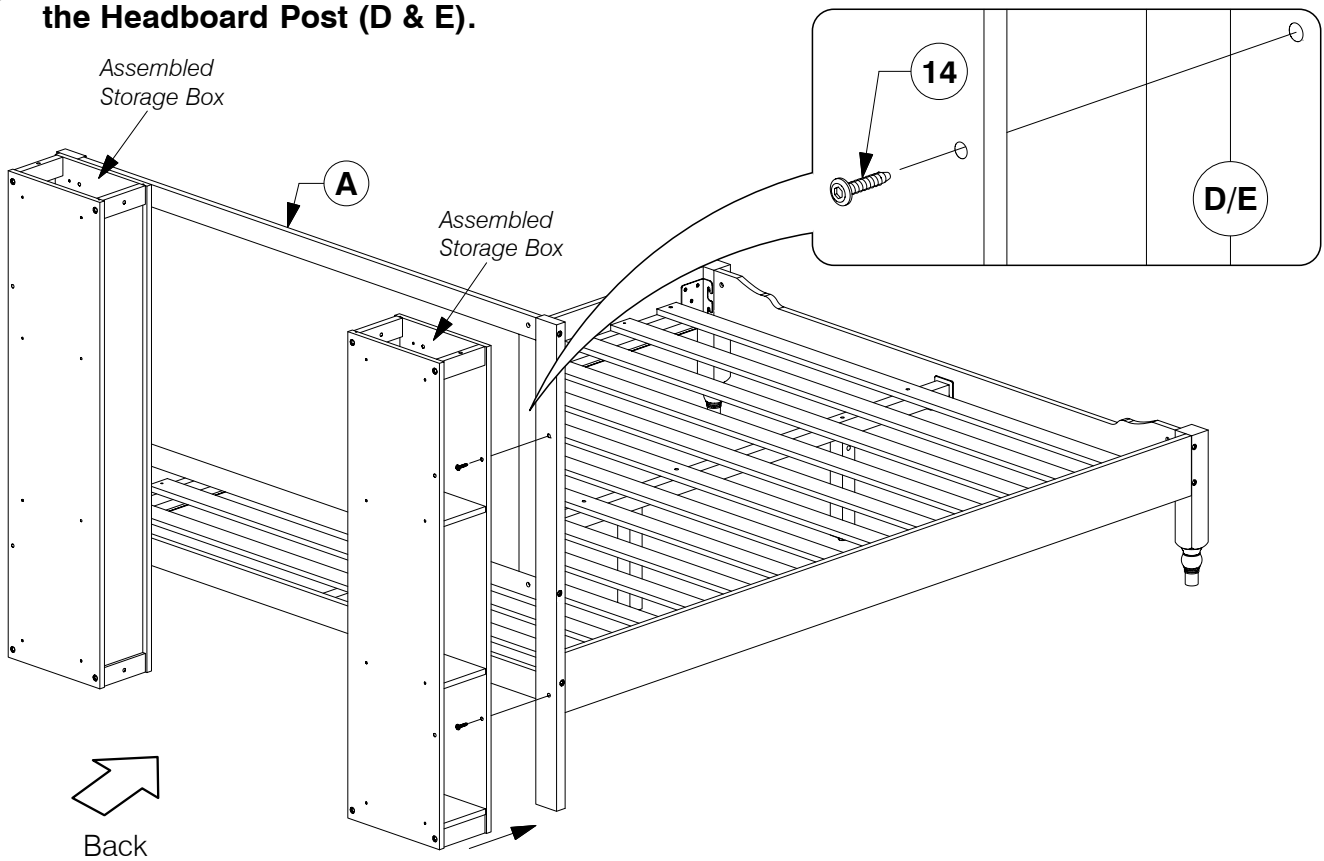

### 18 Fit the 'L' Brackets to the Headboard Panel (A).

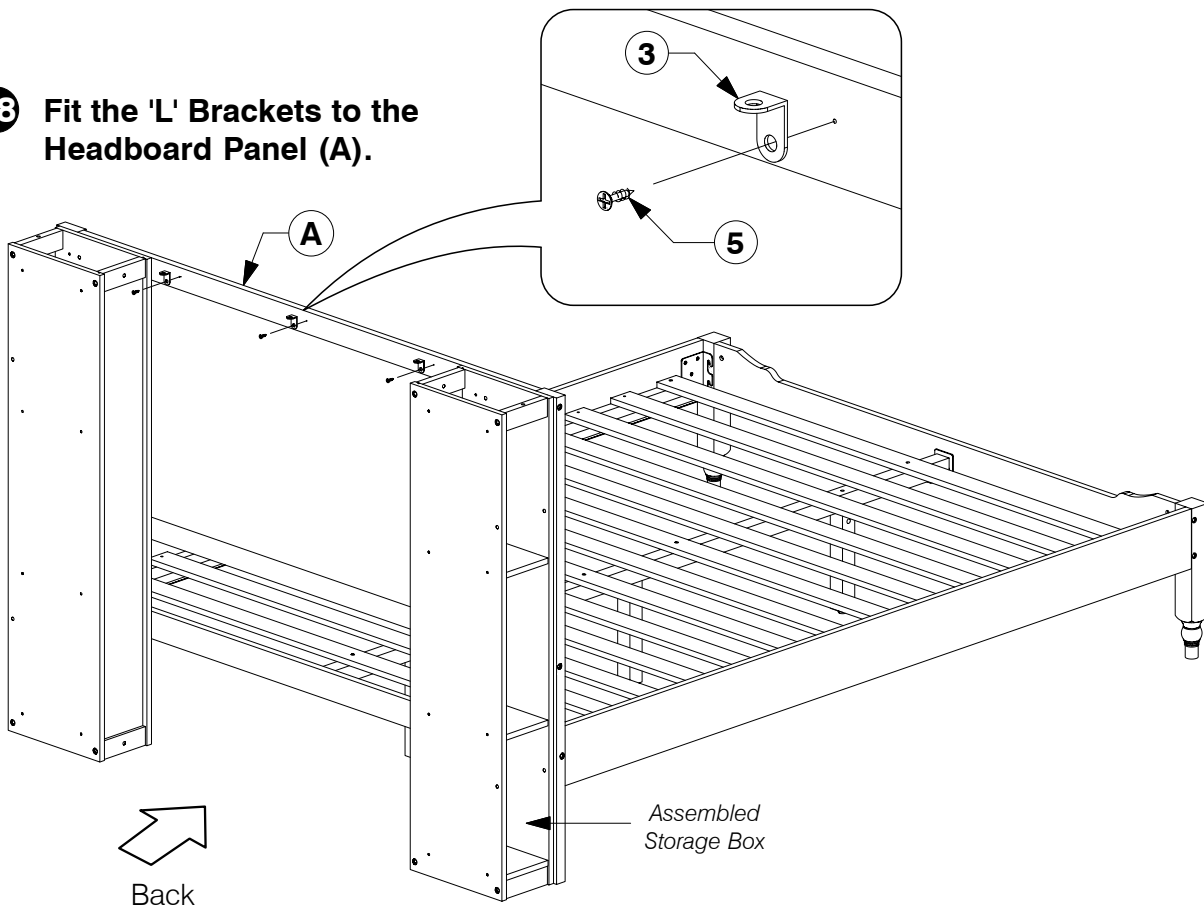

# 0018 Queen Bed

## Assembly Instructions

W11-0919

- 19** Fit the Storage Support Bar (N) in place.

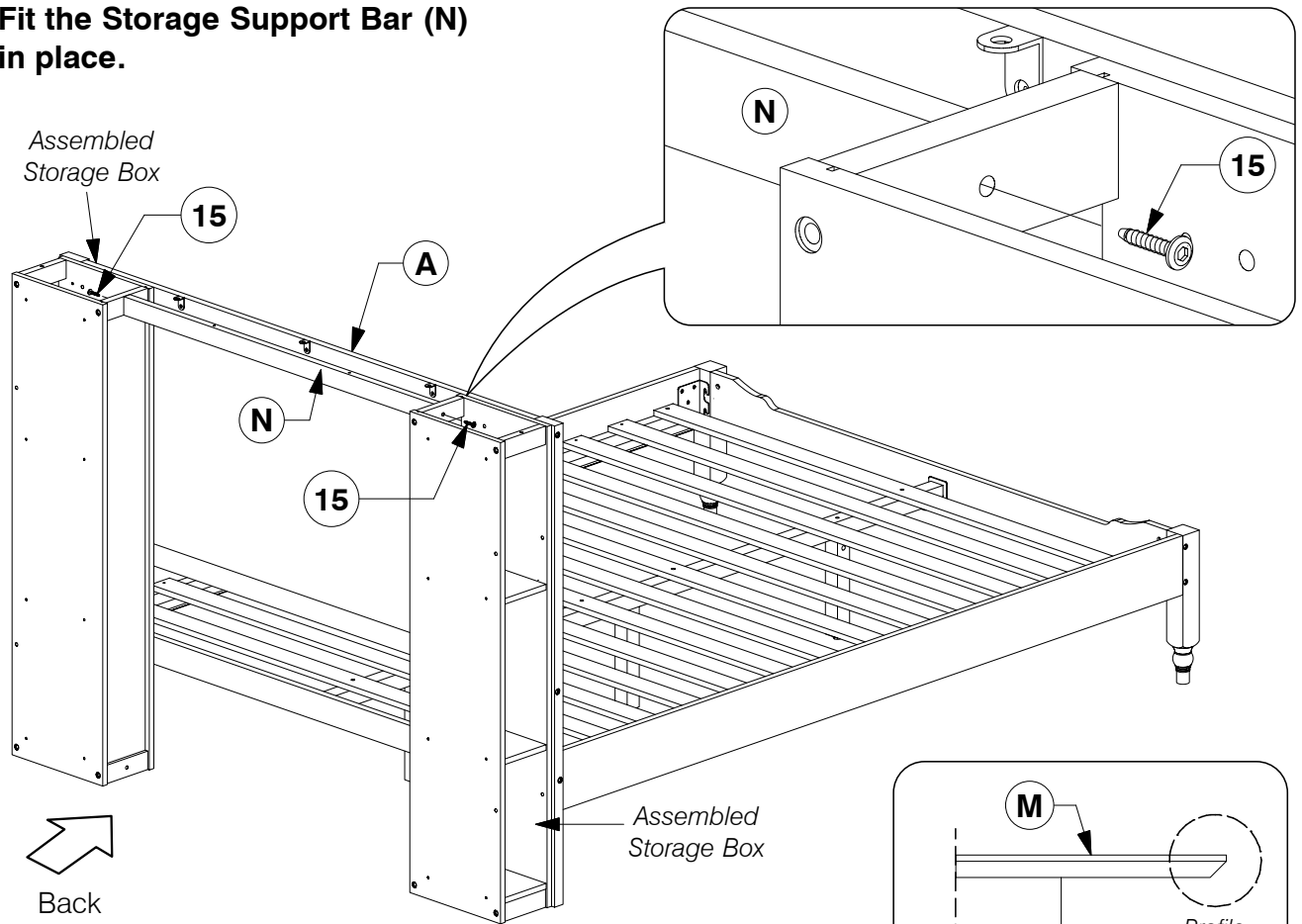

- 20** Fit the Headboard Top Panel (M) on top of the assembled Storage Box & Headboard.

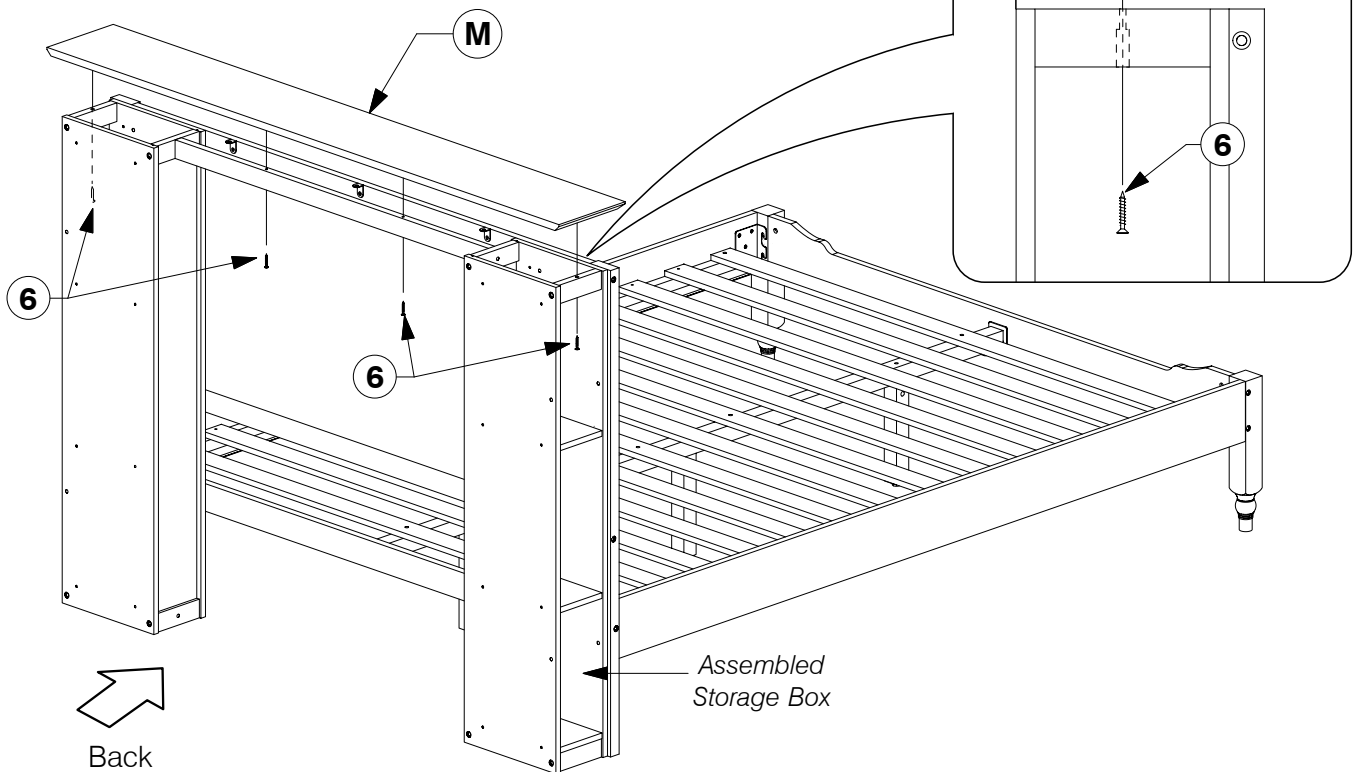

# 0018 Queen Bed

## Assembly Instructions

WII-0919

**21** Tighten the Top Cap (M) with M4 x 16mm Wood Screws.

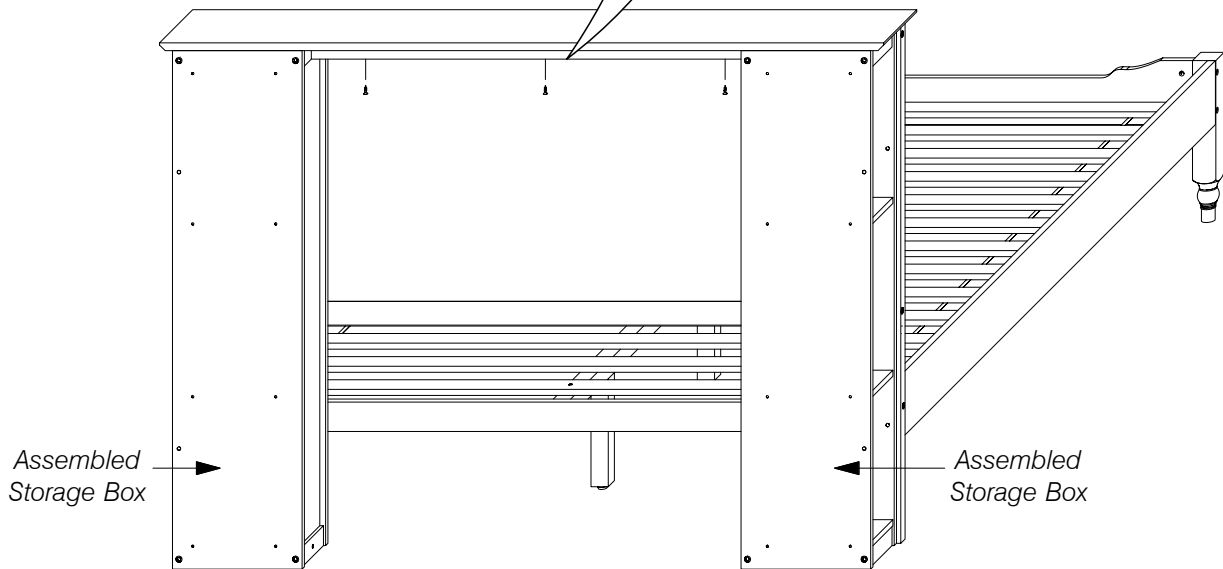
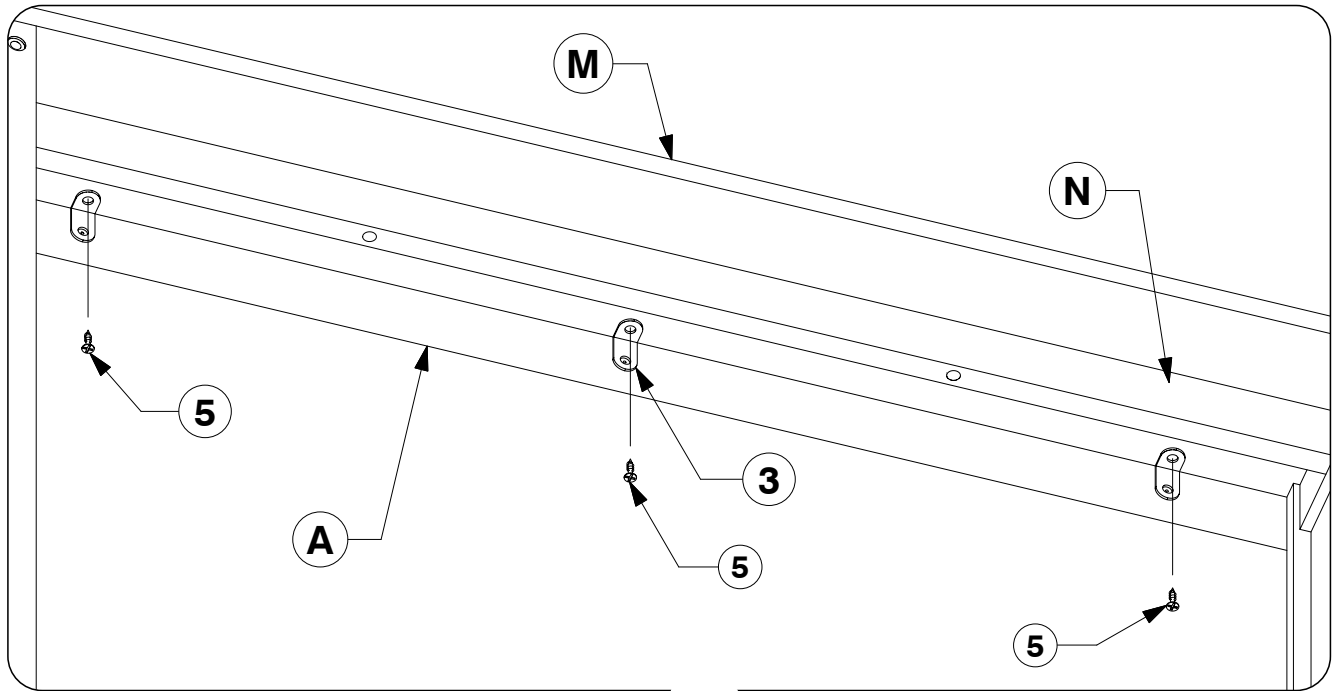

Back