

0008 S Full Bed

Assembly Instructions

WI-0221

1 Assembled View

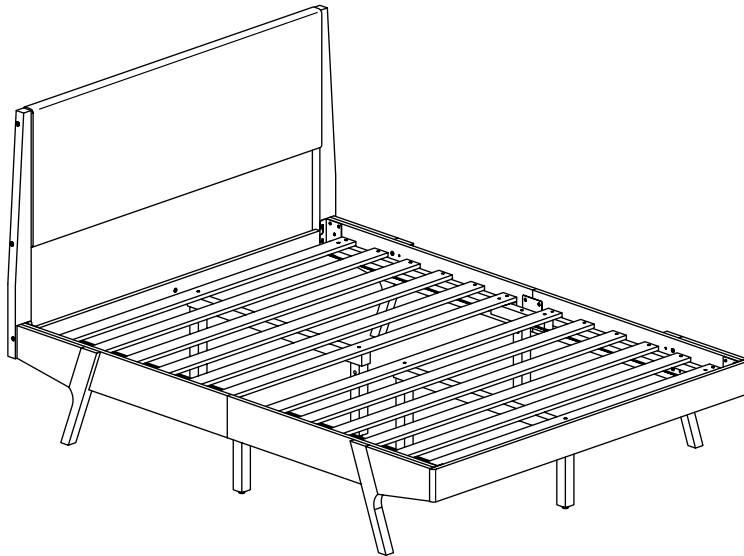

Note: Do not assemble using power tools. This can cause the bolts to be overtightened

2 Parts List

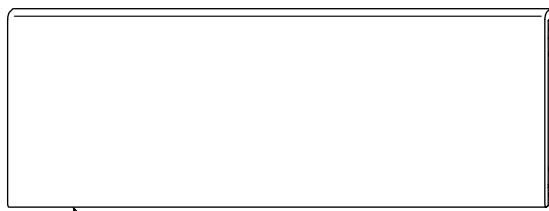

A Headboard Panel x 1

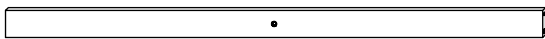

B Headboard Support x 1

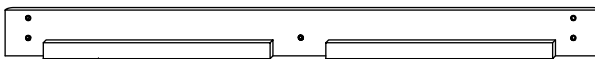

C Footboard Panel x 1

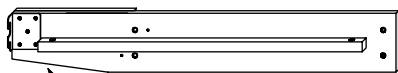

D Side Rail (Left Hand) x 2

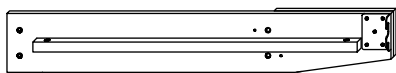

E Side Rail (Right Hand) x 2

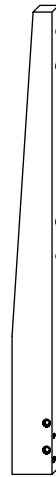

F Headboard Post (Left Hand) x 1

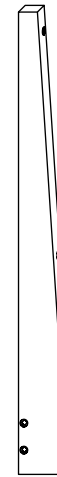

G Headboard Post (Right Hand) x 1

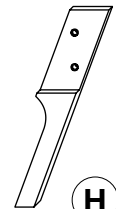

H Bed Post (Left Hand) x 2

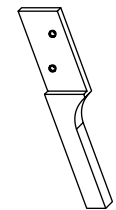

J Bed Post (Right Hand) x 2

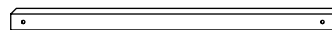

K Long Support x 2

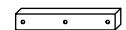

L Support Bar x 2



M Support Leg x 6

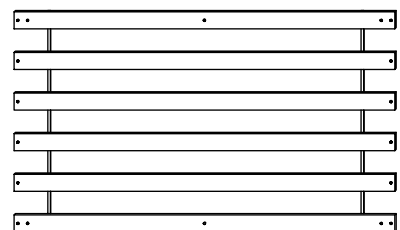

N Set of Bed Slats x 2

0008 S Full Bed

Assembly Instructions

WI-0221

3 Hardware List



1 Allen Key
x 1

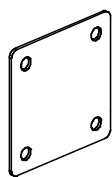

2 Metal Plate
x 2

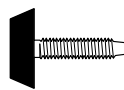

3 Adjustable
Foot x 6

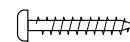

4 Wood Screw
(M4 x 32mm) x 24



5 Wood Dowel
(M10 x 40mm)
x 6



6 Barrel
Nut x 12



7 Spring
Washer
x 8



8 M6 Flat
Washer
x 26



9 M6
JCN Nut
x 4



10 M8 Flat
Washer
x 4



11 M6 x
15mm JCB
x 8



12 M6 x
20mm JCB
x 8

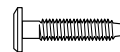

13 M6 x
30mm JCB
x 8

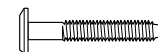

14 M6 x
40mm JCB
x 8



15 M6 x 50mm JCB
x 4



16 M6 x 90mm JCB
x 2



17 M6 x 100mm JCB
x 10

4 Fit the Adjustable foot to the bottom of the Support Leg (M).

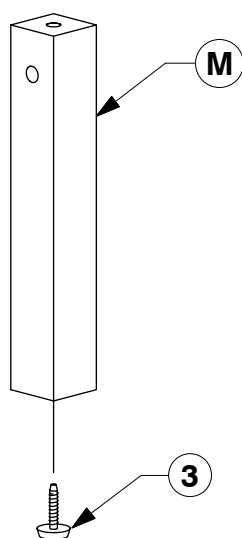

5 Fit the Support Bar (L) to the Support Leg (M).

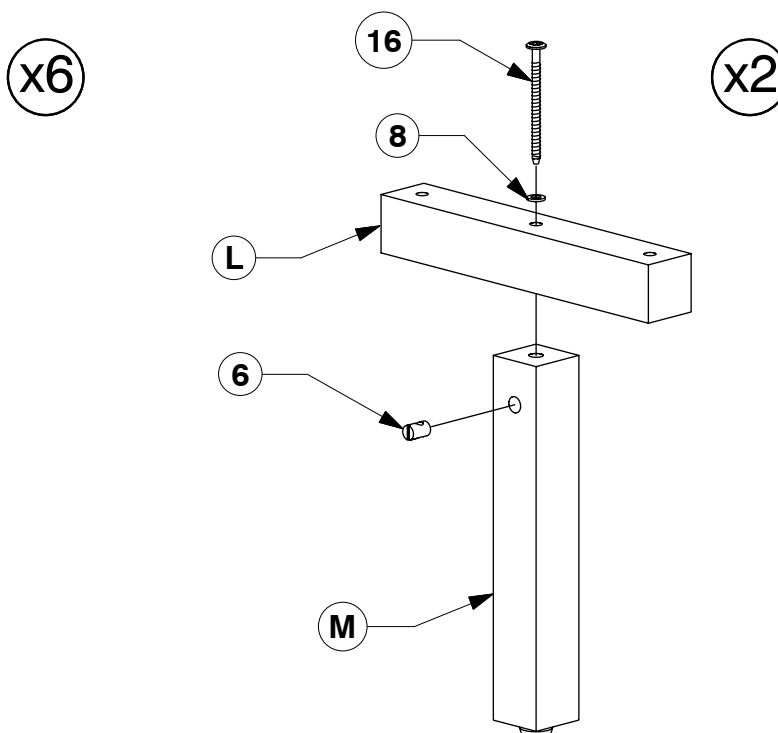

0008 S Full Bed

Assembly Instructions

WI-0221

- 6** Assemble the Headboard Panel (A) & Headboard Support (B) to the Headboard Post (F & G).

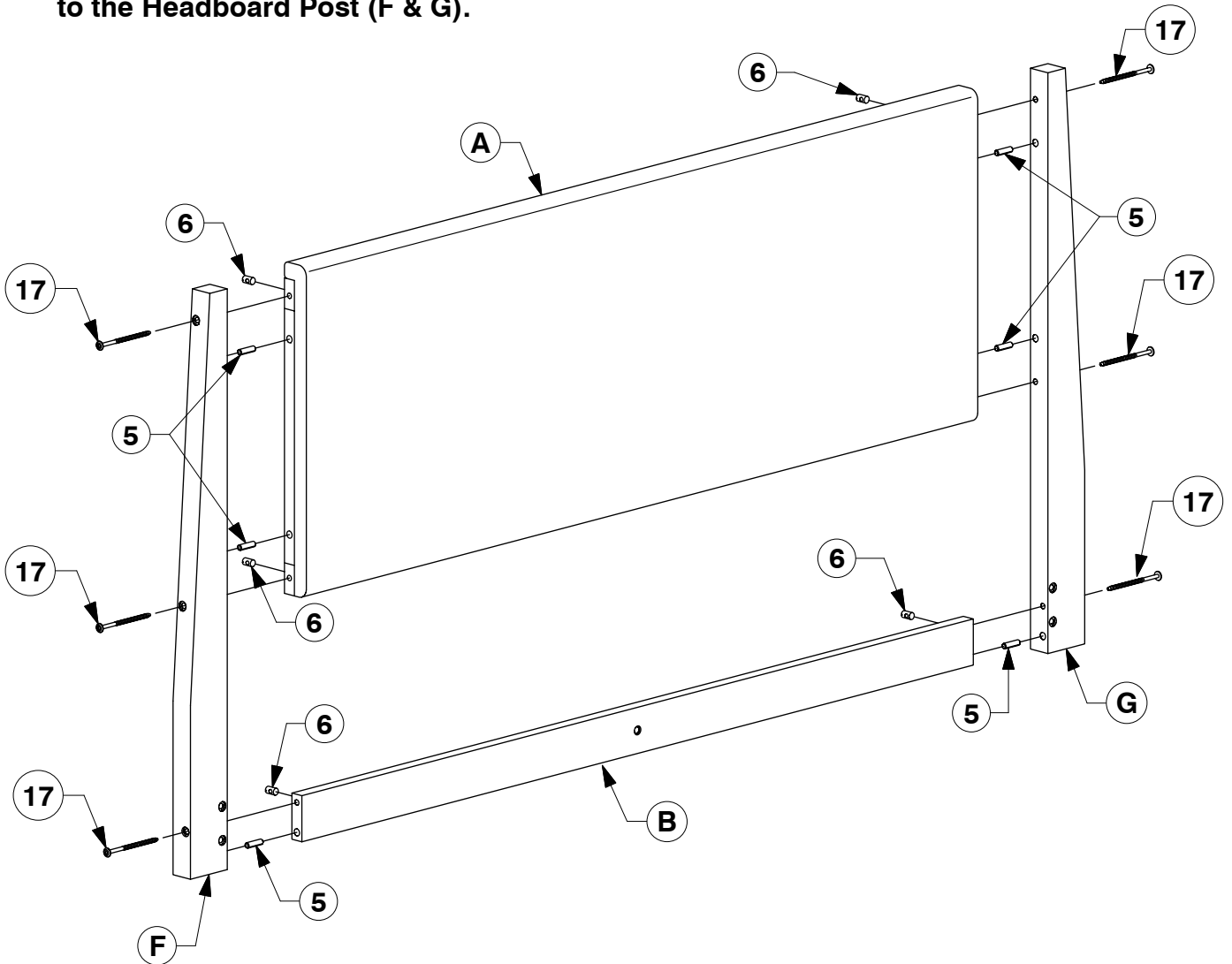

- 7** Fit the Metal Plate to the Side Rail (D & E).

x2

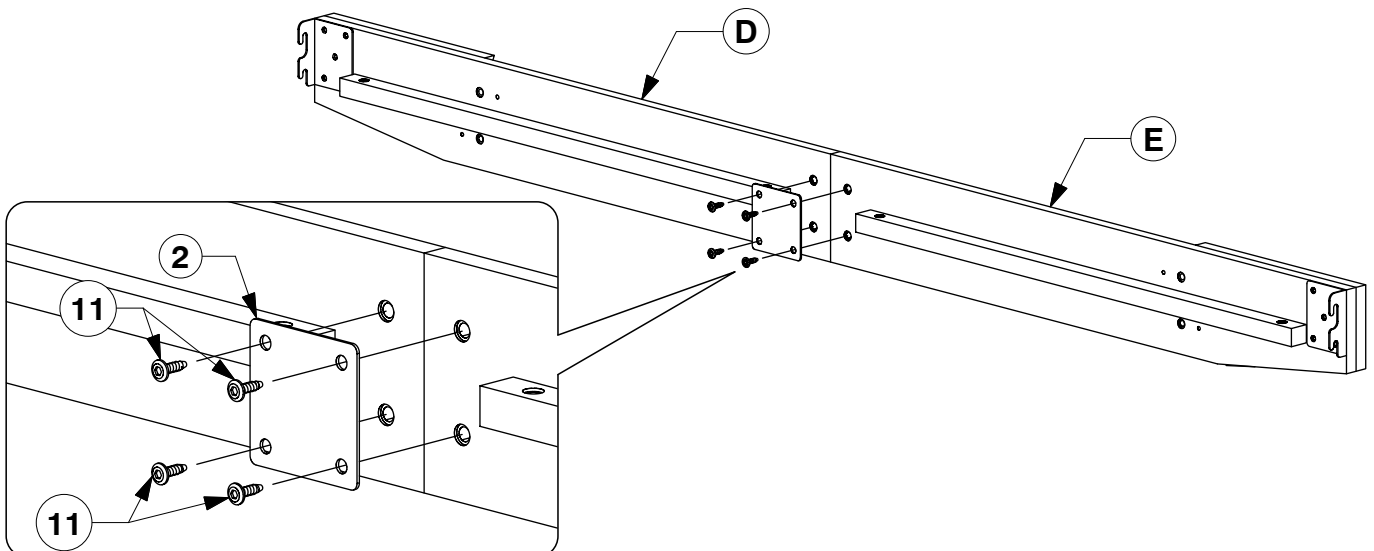

0008 S Full Bed

Assembly Instructions

WI-0221

8 Fit the Bed Post (H & J) to the Side Rail (D & E).

x2

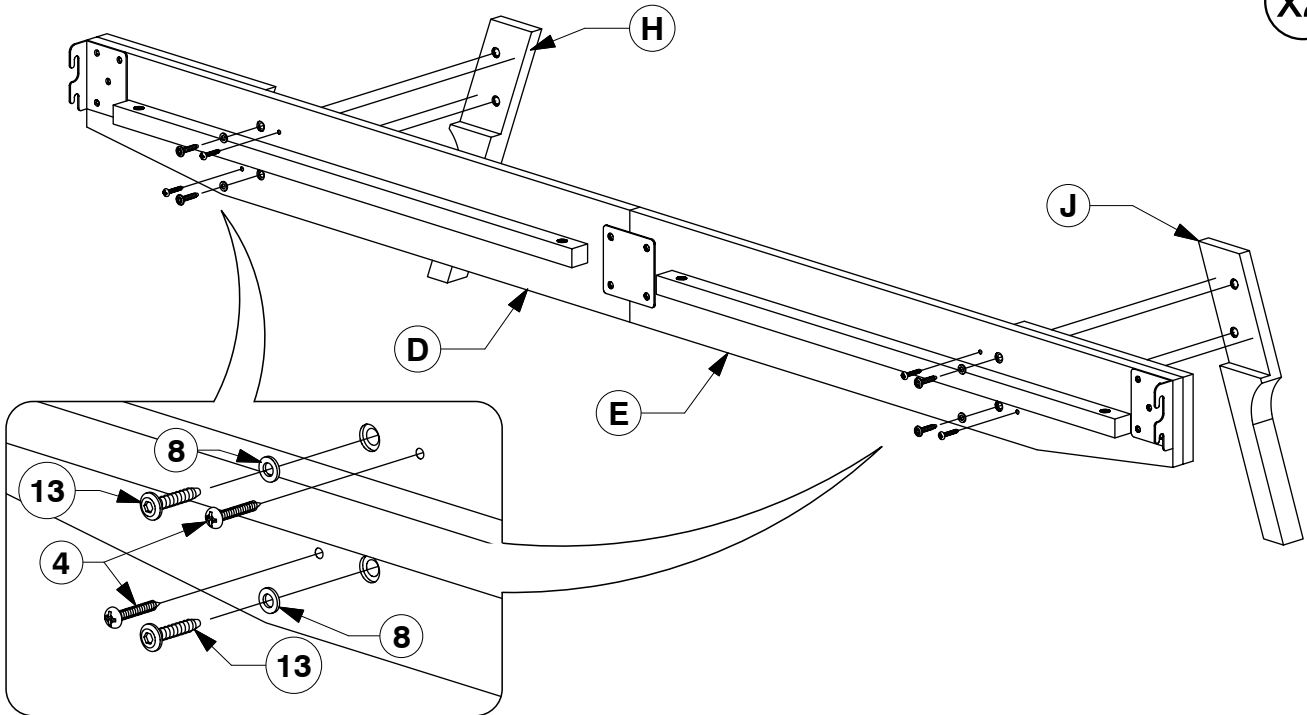

9 Assemble the Side Rail (D & E) to the Headboard & Footboard Panel (C).

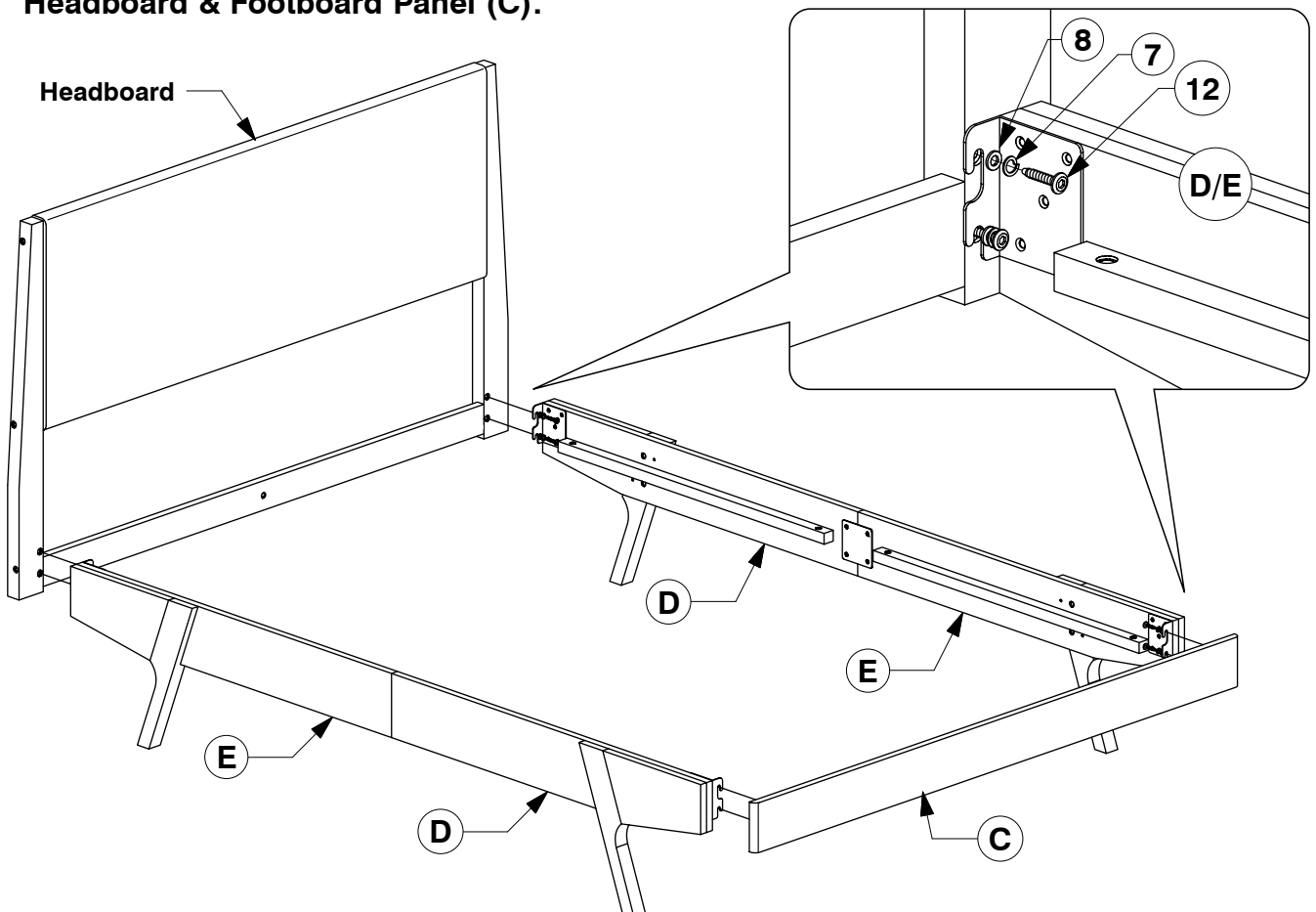

0008 S Full Bed

Assembly Instructions

WI-0221

- 10** Fit the Slats (N) to the Long Support (K) & Support Leg (M).

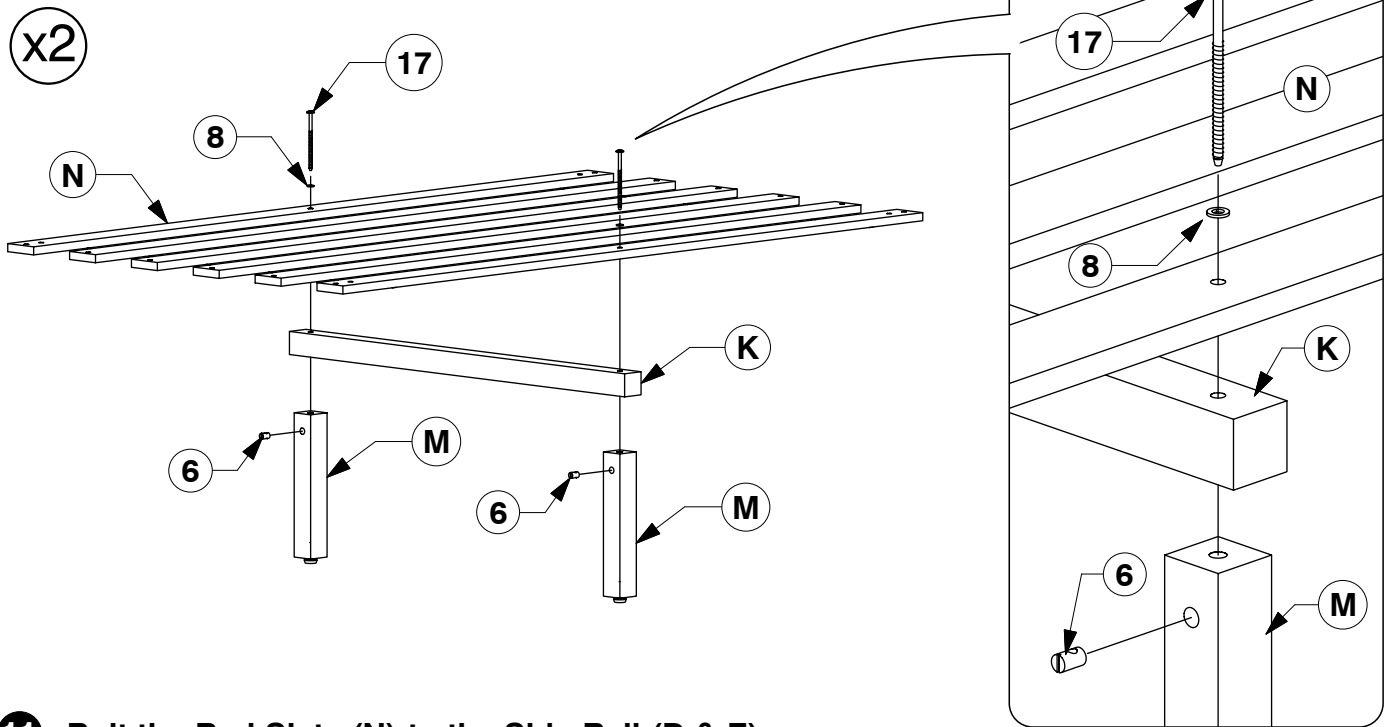

- 11** Bolt the Bed Slats (N) to the Side Rail (D & E).

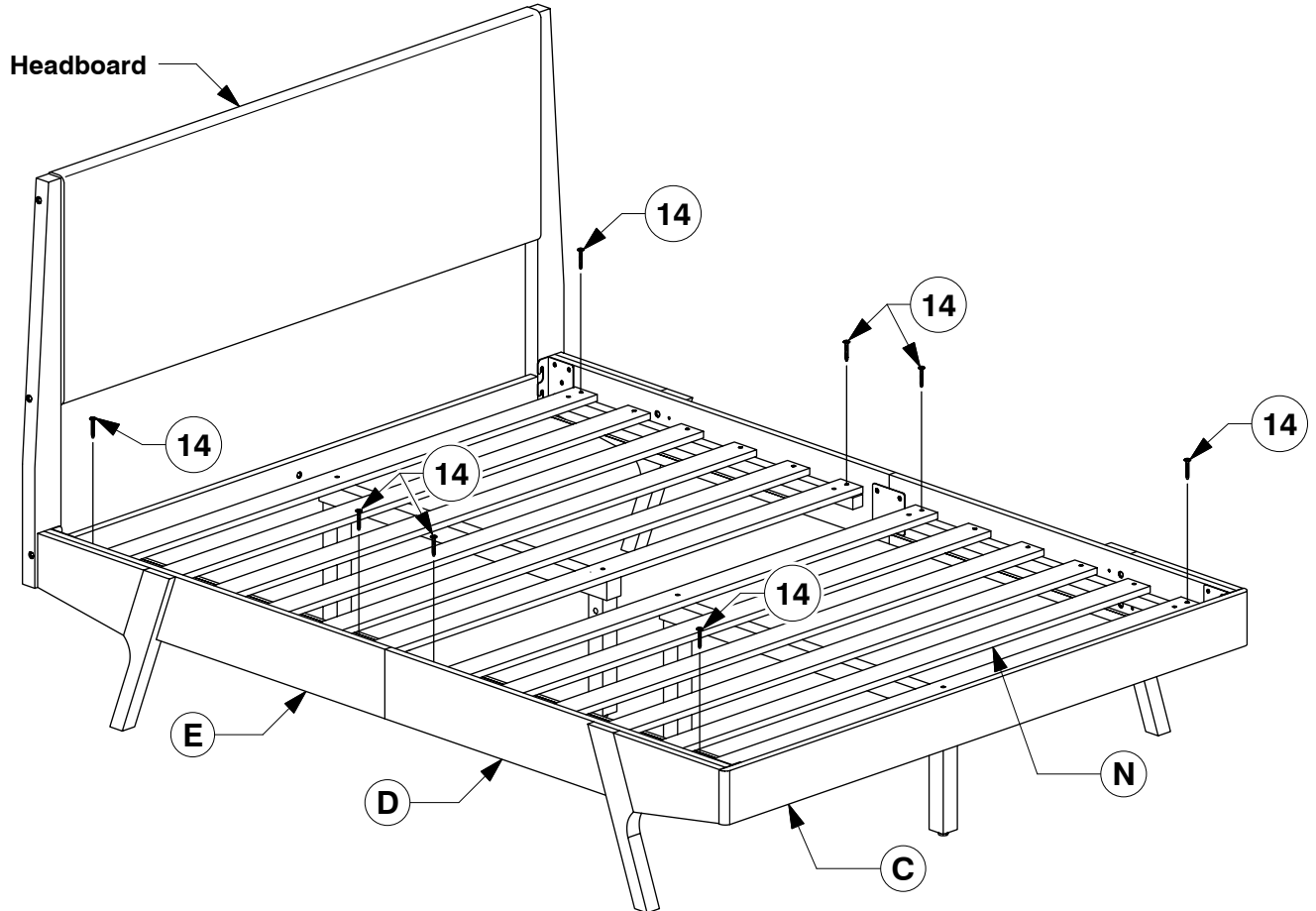

0008 S Full Bed

Assembly Instructions

WI-0221

- 12** Screw the Bed Slats (N) to the Side Rail (D & E).

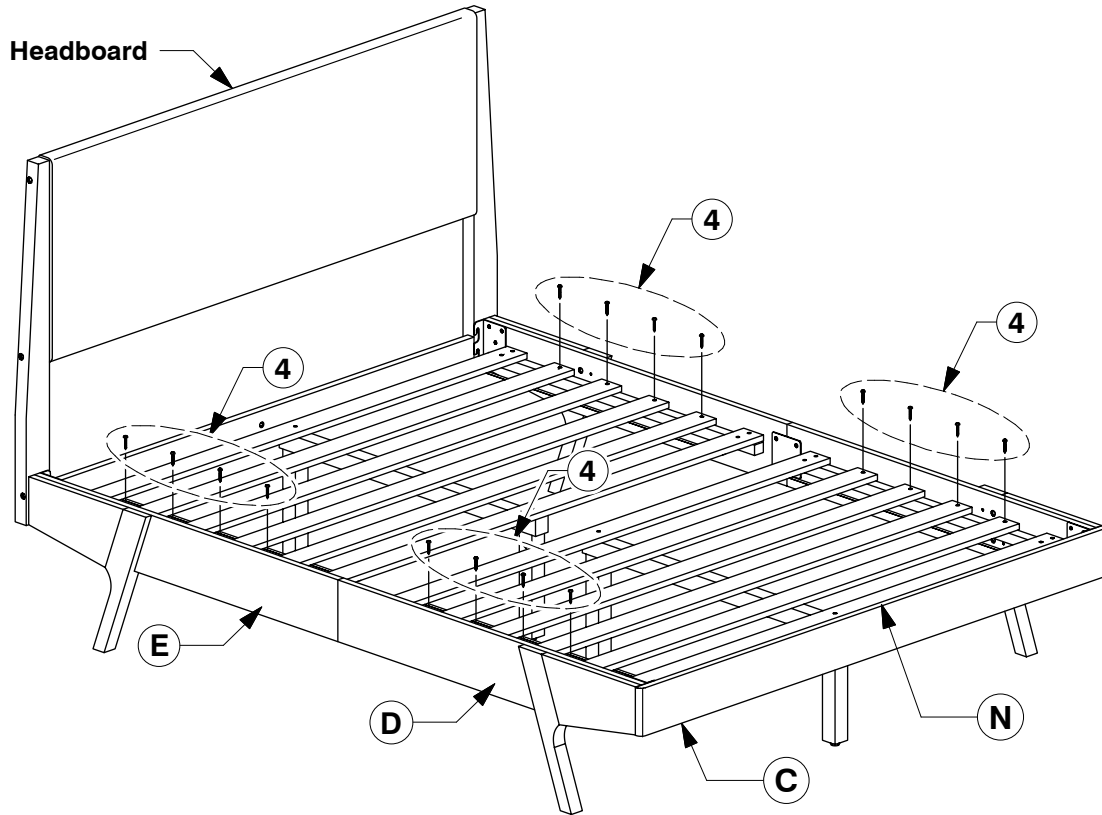

- 13** Lastly, fit the Support Bar (L) in place.

