

# Full Bed

## Assembly Instructions

WII-0419

### 1 Assembled View

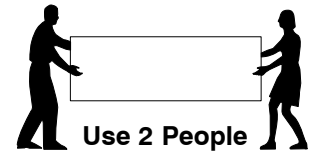
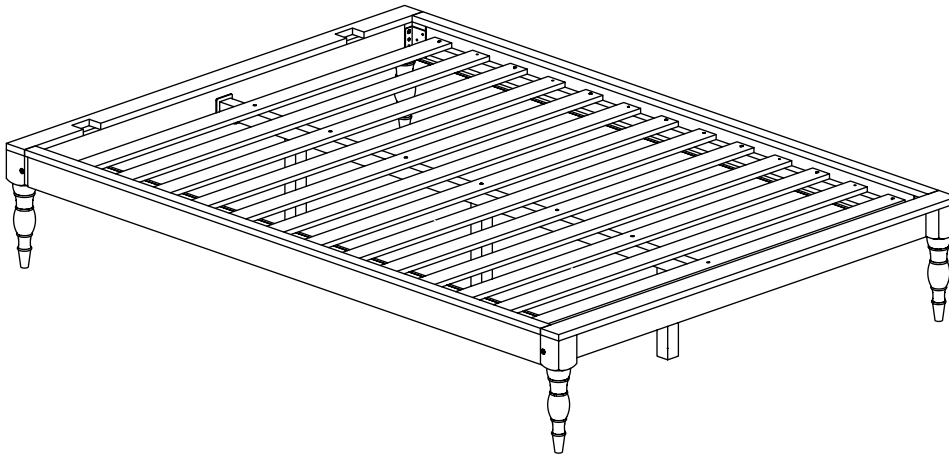

**Note:** Do not assemble using power tools. This can cause the bolts to be overtightened

### 2 Parts List

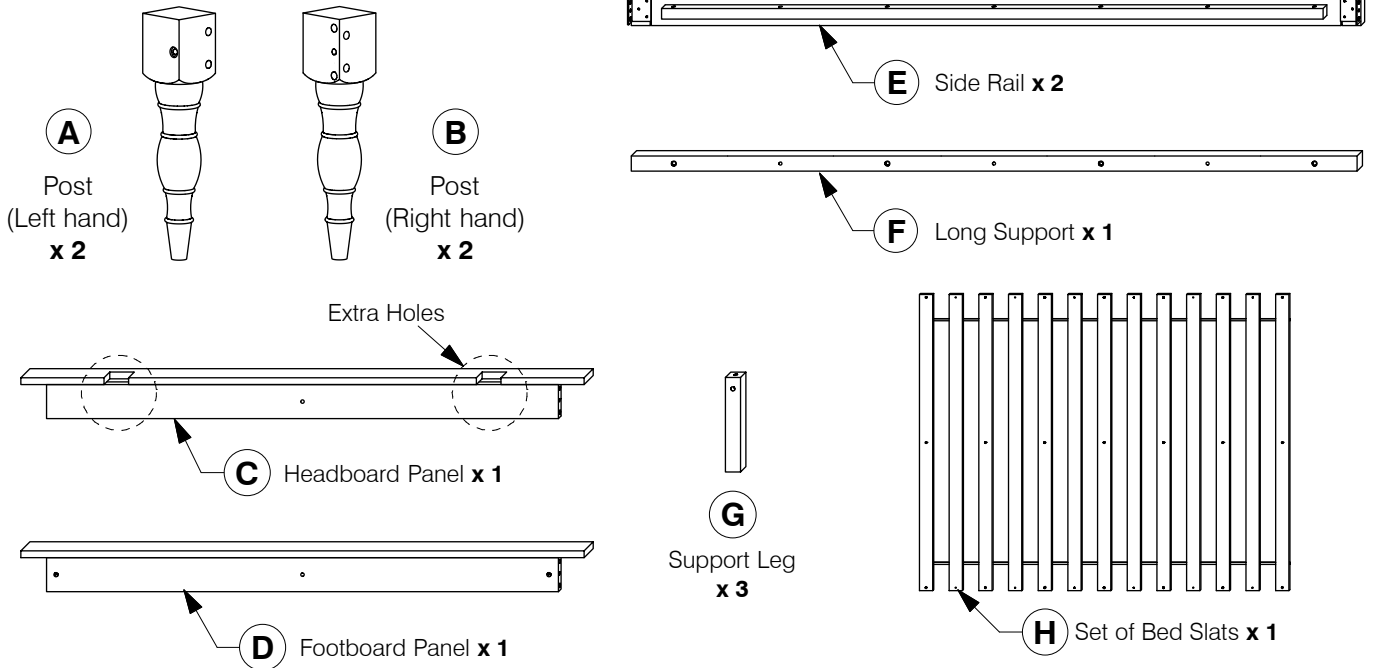

### 3 Hardware List

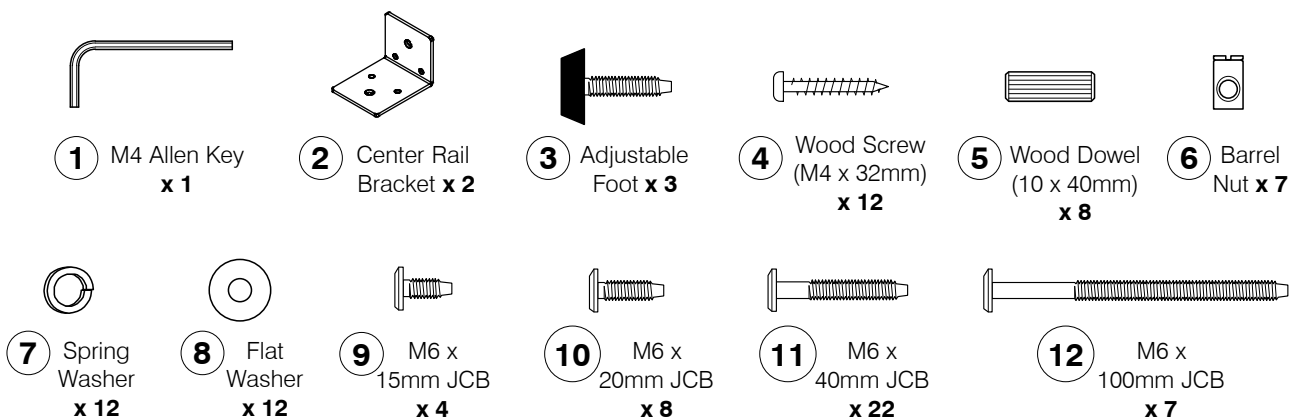

# Full Bed

## Assembly Instructions

WII-0419

- 4** Fix the Adjustable foot to the bottom of the Support Leg (G).

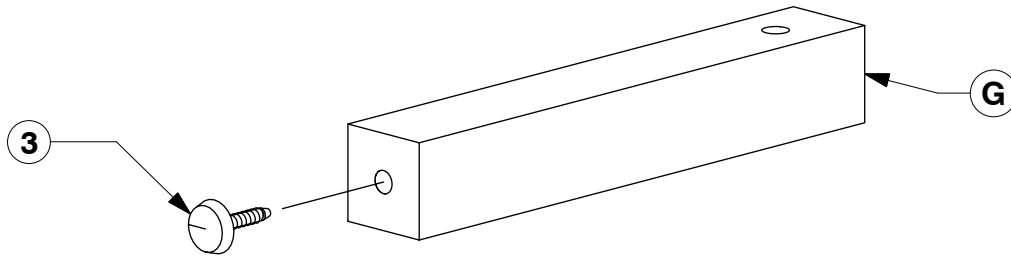

- 5** Assemble the Post (A & B) to the Headboard / Footboard Panel (C & D). Fit the Center Rail Bracket to the Headboard / Footboard Panel (C & D).

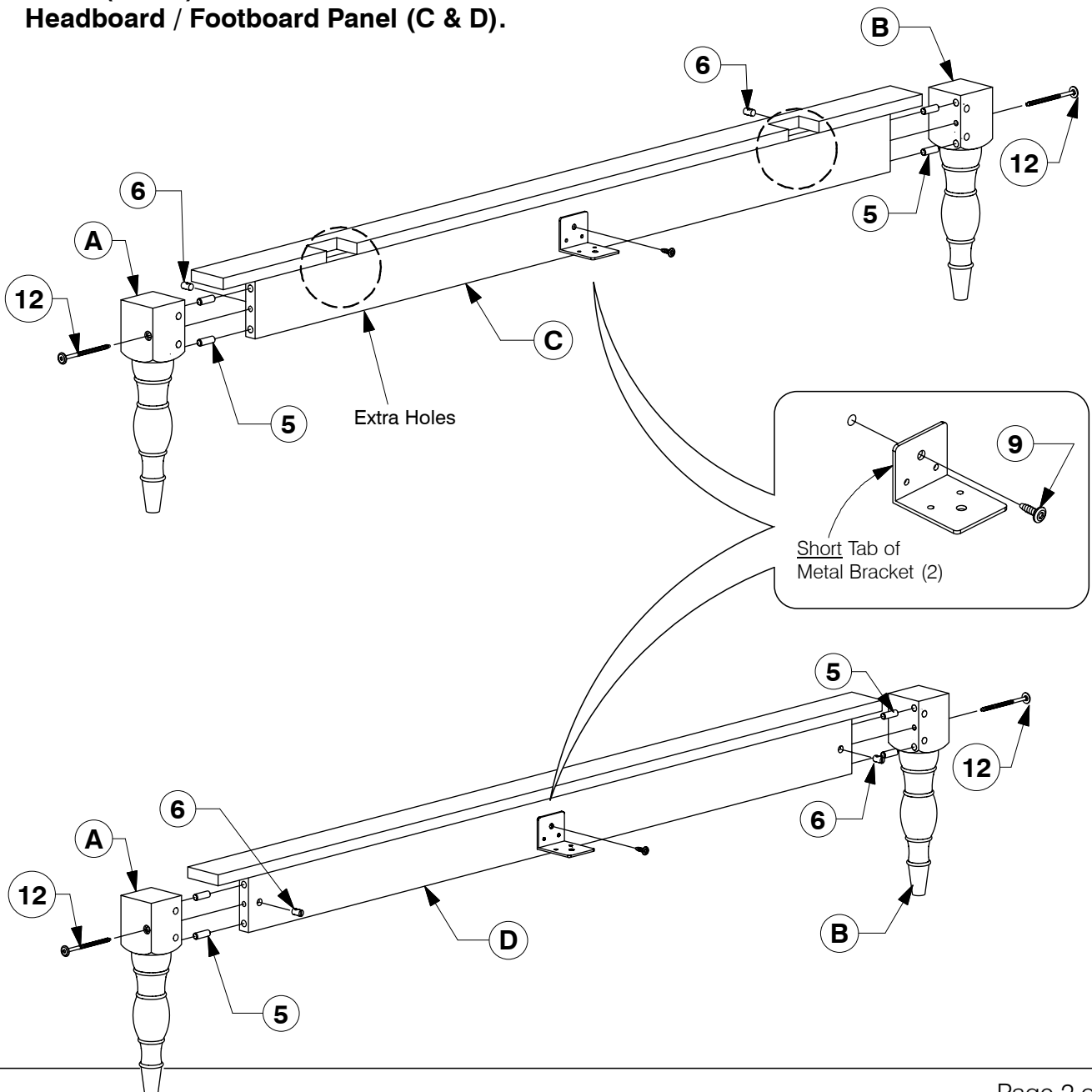

# Full Bed

## Assembly Instructions

WII-0419

- 6 Assemble the Side Rail (E) to the Headboard & Footboard Panel (C & D).**

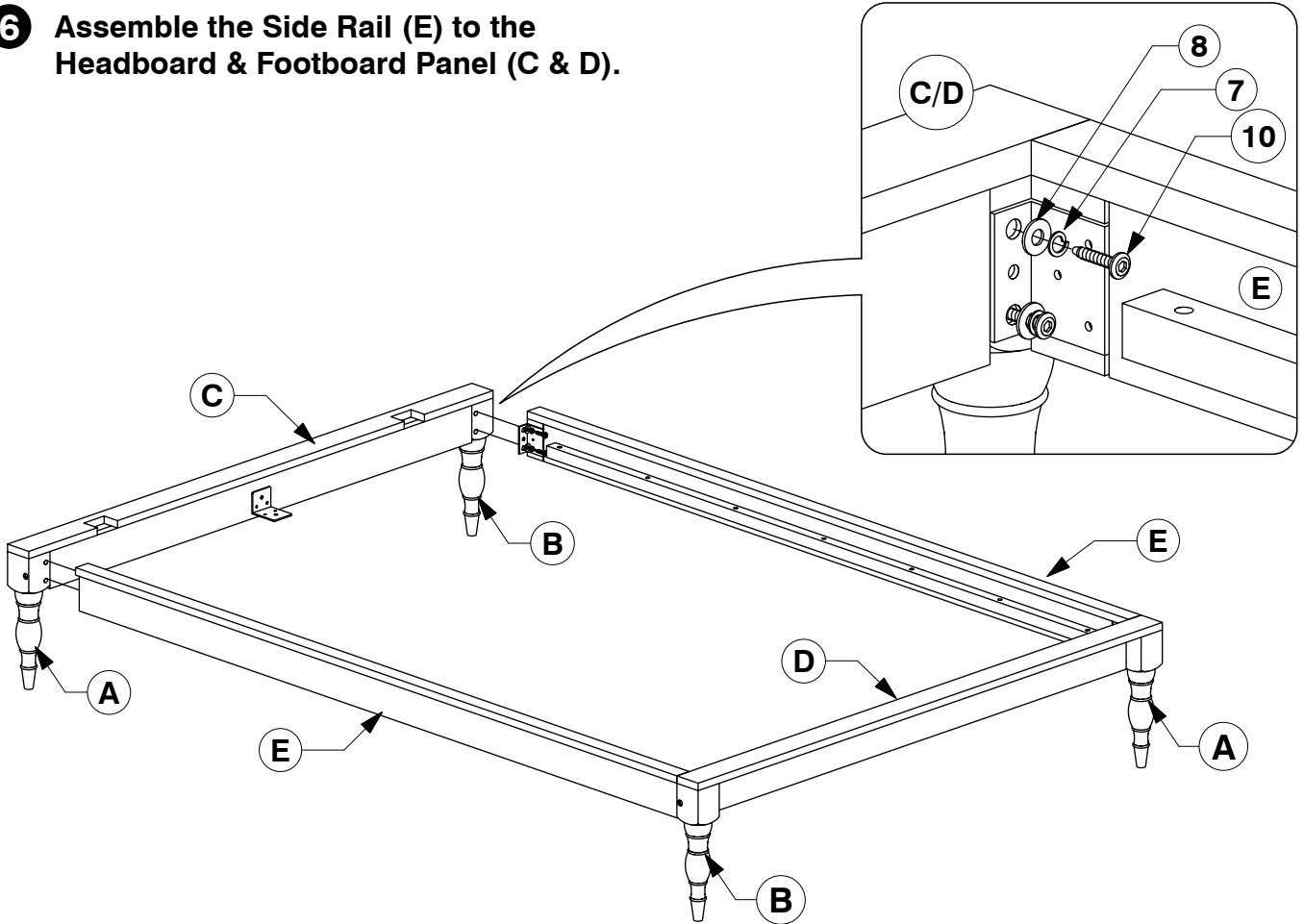

- 7 Bolt the Long Support (F) to the Center Rail Brackets (2) on the Headboard & Footboard Panel (C & D).**

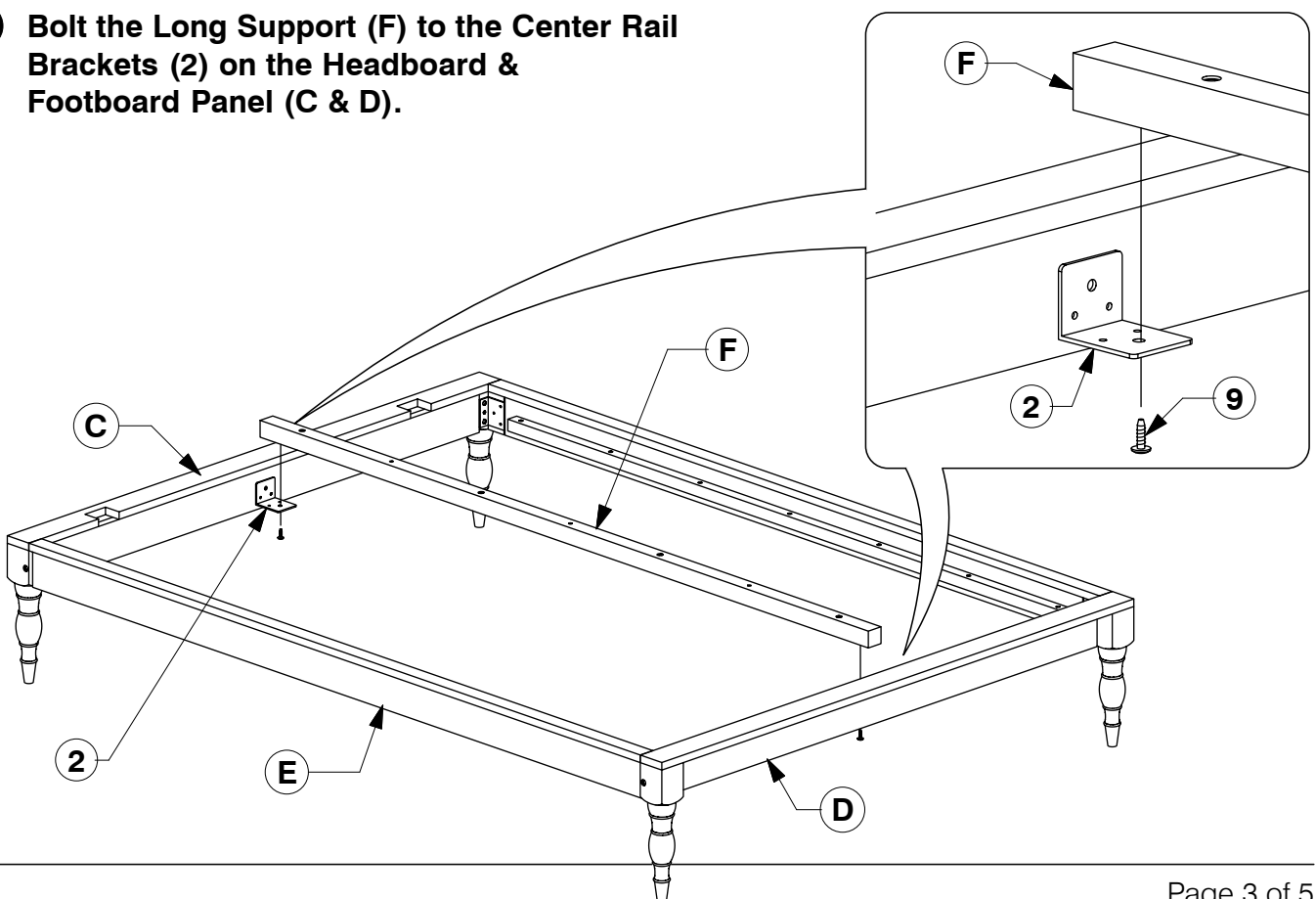

# Full Bed

## Assembly Instructions

WII-0419

- 8** Fit the first 3 Slats and assemble the Support Leg (G) to the Bed Slat (H). Bolt & screw the Bed Slats (H) to the Side Rail (E) & Long Support (F).

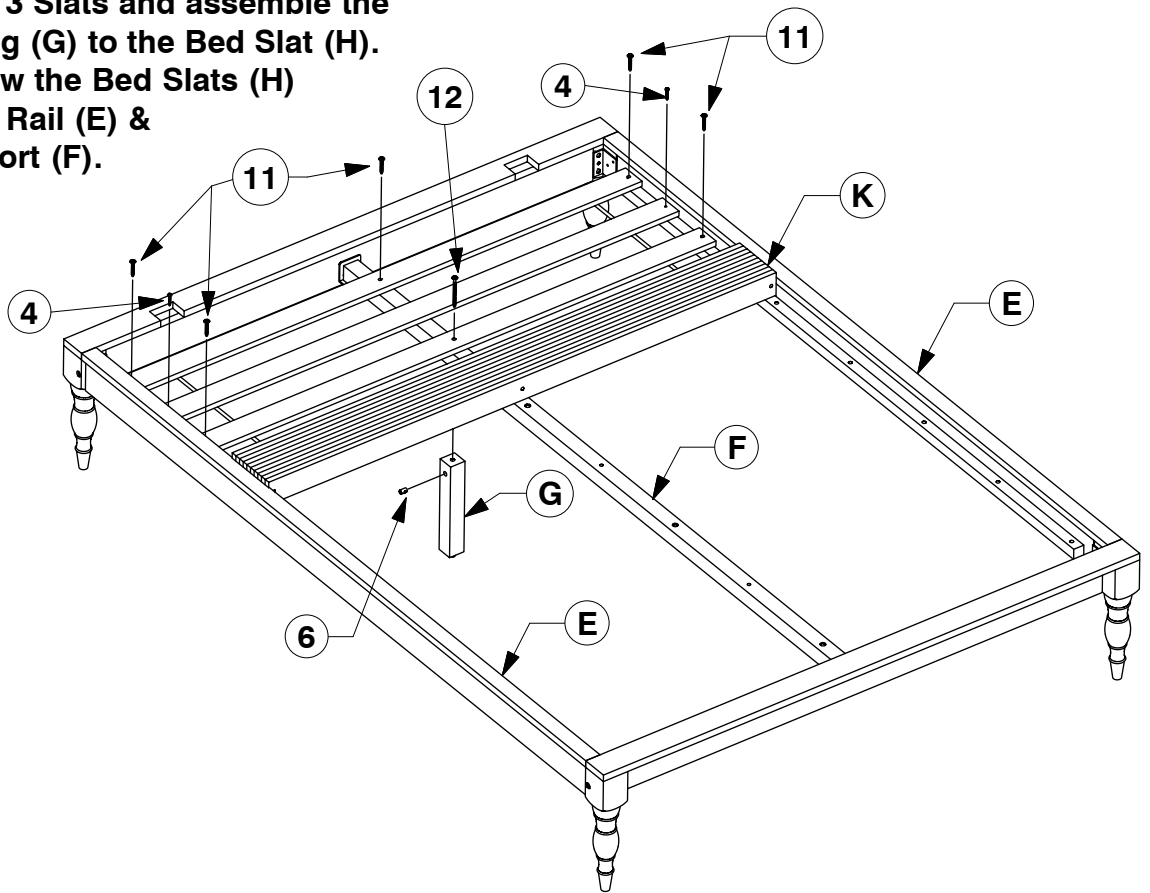

- 9** Fit the other Slats out and assemble the Support Leg (G) to the Bed Slat (H). Bolt & screw the Bed Slats (H) to the Side Rail (E) & Long Support (F).

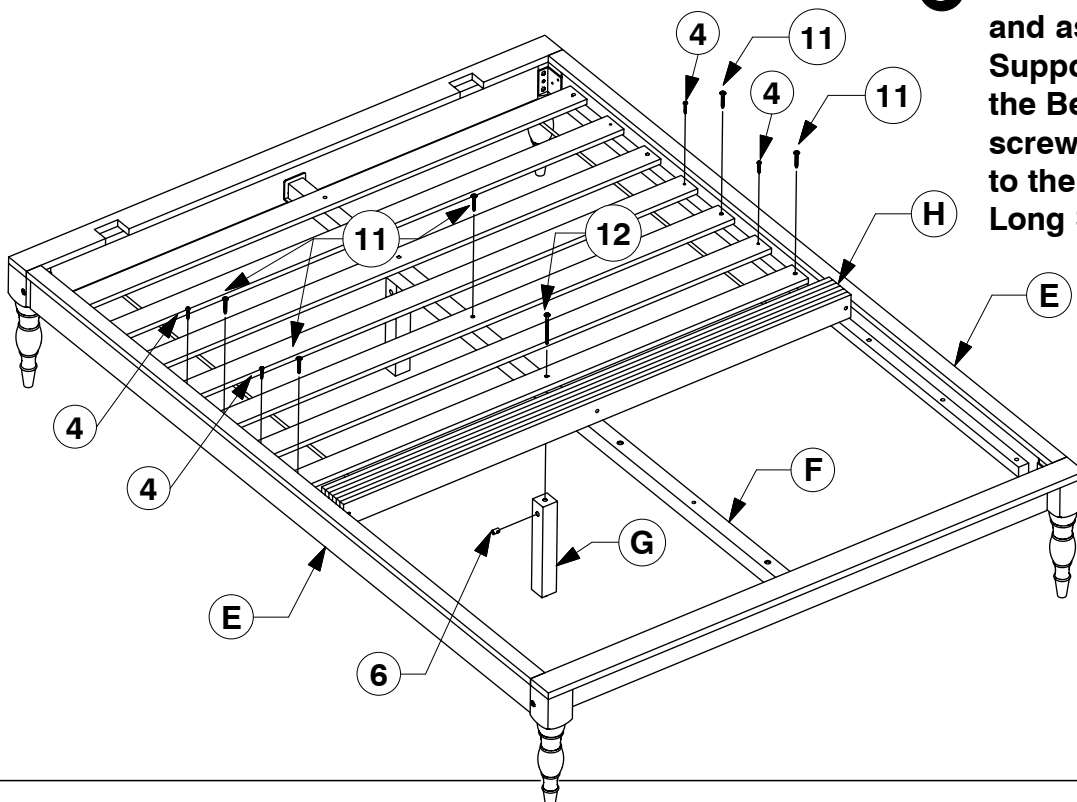

# Full Bed

## Assembly Instructions

WII-0419

- 10** Fit the other Slats out and assemble the Support Leg (G) to the Bed Slat (H). Bolt & screw the Bed Slats (H) to the Side Rail (E) & Long Support (F).

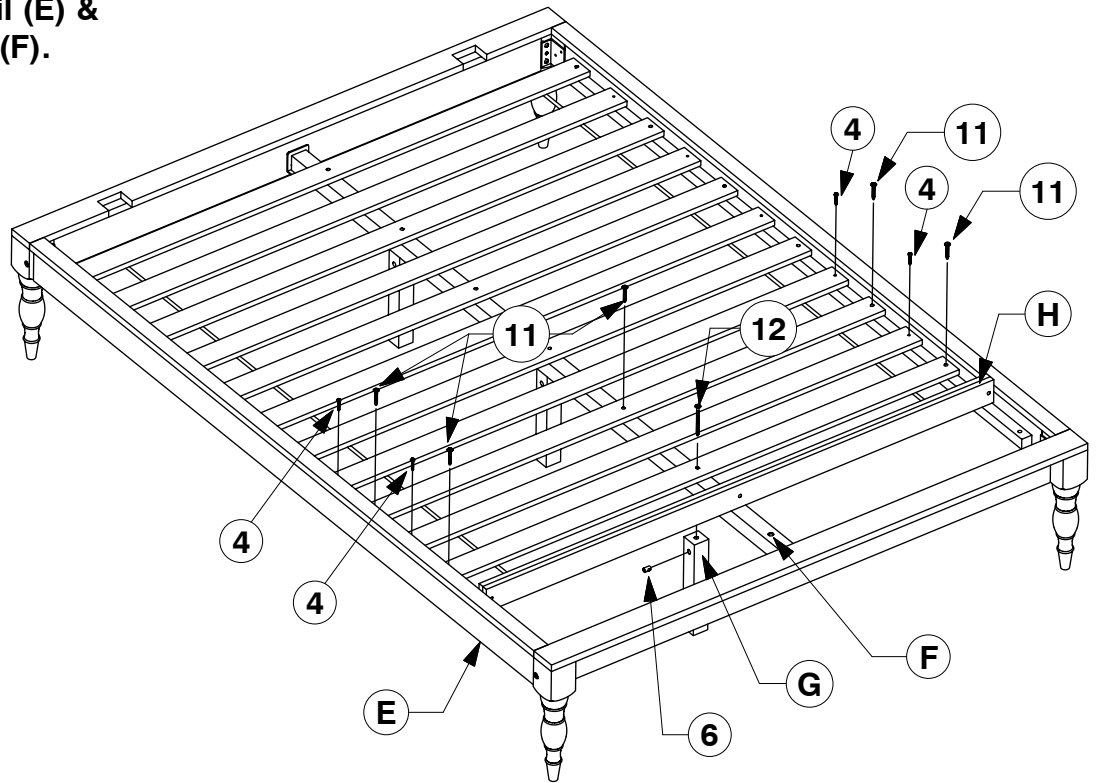

- 11** Bolt & screw the remaining Bed Slats (H) to the Side Rail (E).

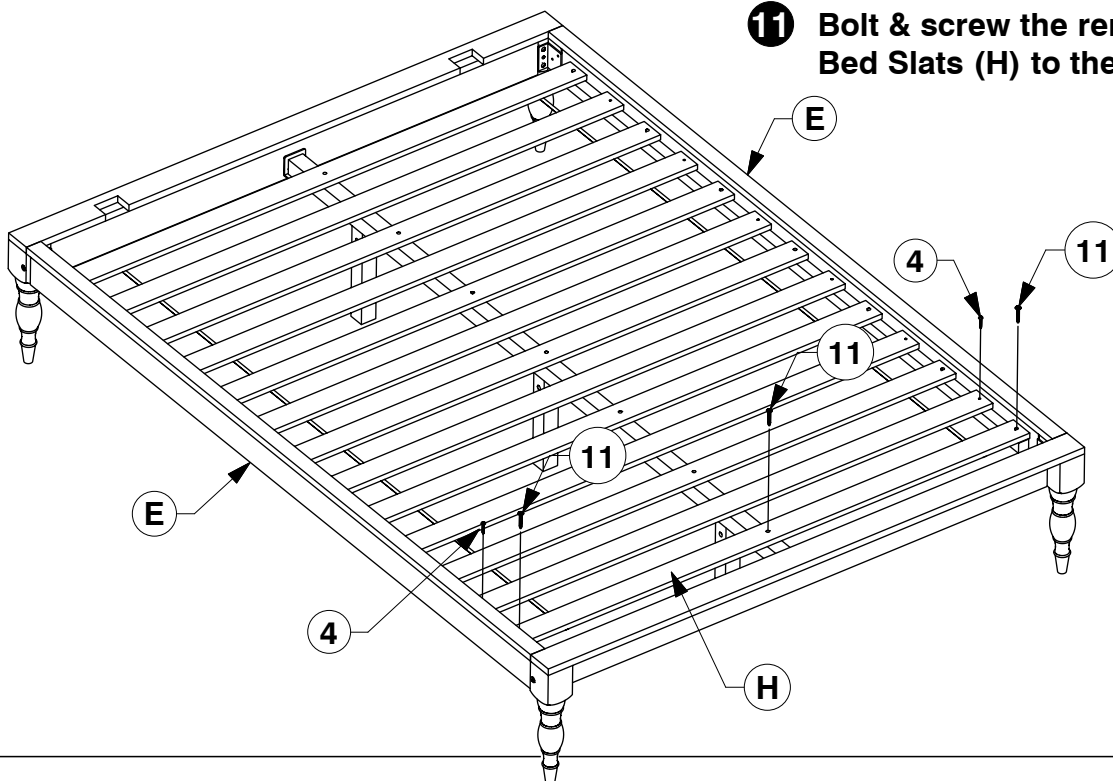

# Full Headboard

## Assembly Instructions

W11-0419

### 1 Parts List

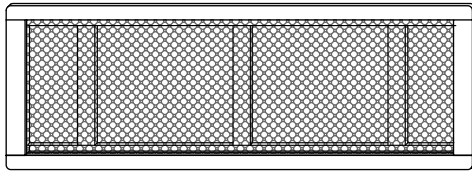

**A** Headboard Panel x 1

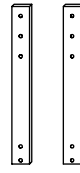

**B** Support Bar x 2

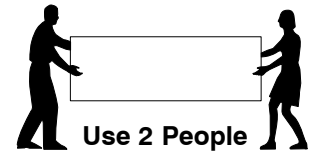

### 2 Hardware List



**1** M6 x 35mm JCB  
x 6



**2** Spring Washer  
x 6



**3** Flat Washer  
x 6



**4** Allen Key  
x 1

**Note:** Do not assemble using power tools. This can cause the bolts to be overtightened

### 3 Assemble the Support Bars (B) to the Headboard Panel.

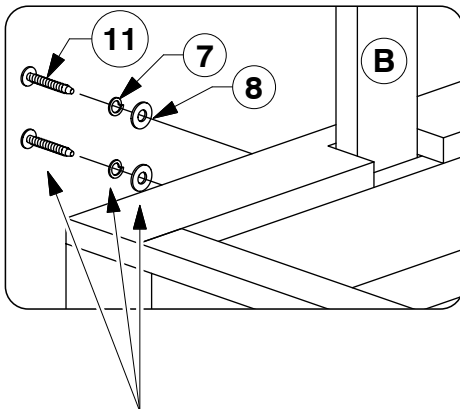

*Note: Bolts & Washers from Footboard, Rails & Slats Box.*

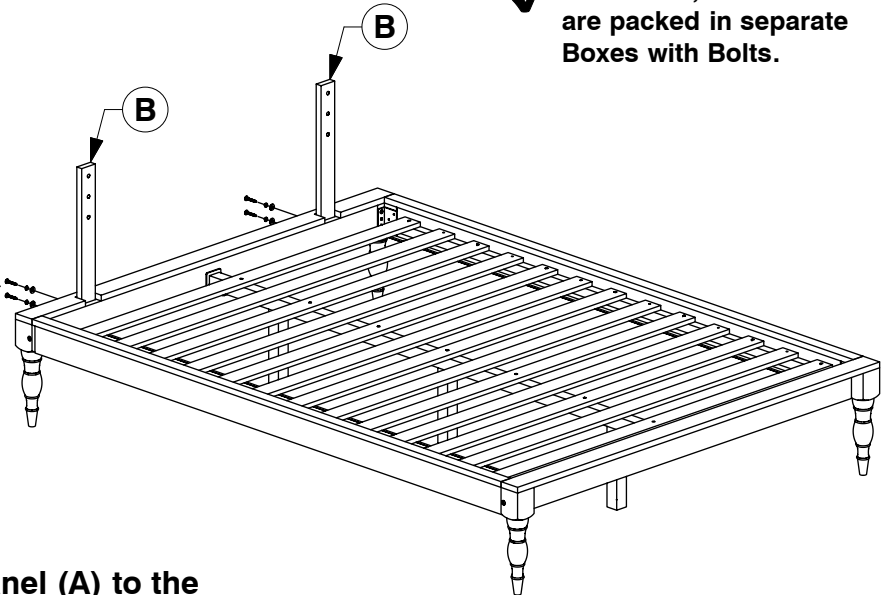

✓ Footboard, Rails & Slats are packed in separate Boxes with Bolts.

### 4 Assemble the Headboard Panel (A) to the Support Bars (B).

