

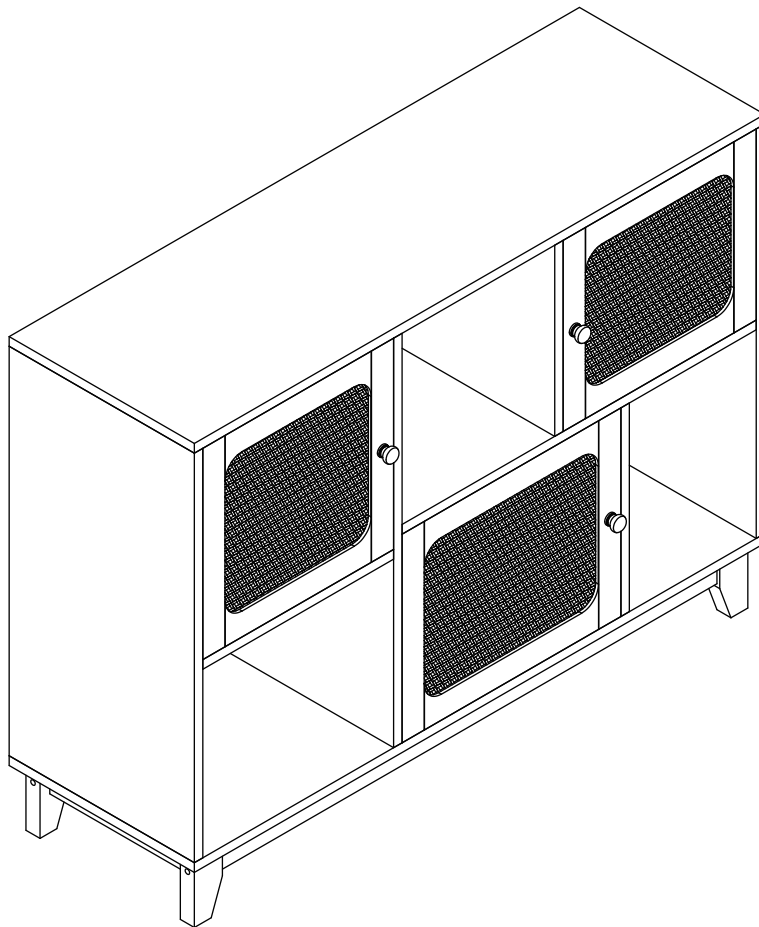

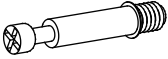







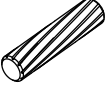
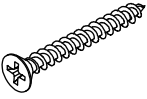



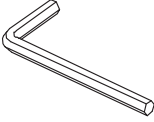



Sideboard

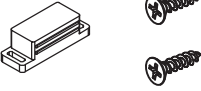

ASSEMBLY INSTRUCTION

HARDWARE LIST

<p>A</p> <p>18 PCS</p>		<p>B</p> <p>18 PCS</p>		<p>C</p> <p>38 PCS</p>		<p>D</p> <p>14 PCS</p>	
<p>E</p> <p>6 PCS</p>	 <p>Ø3.5x12mm</p>	<p>F</p> <p>3 PCS</p>	<p>F-1 F-2</p> 	<p>G</p> <p>4 PCS</p>	<p>G-1 G-2</p> 	<p>H</p> <p>12 PCS</p>	
<p>I</p> <p>1 PCS</p>		<p>J</p> <p>4 PCS</p>		<p>K</p> <p>2 PCS</p>	<p>K-1 K-2</p> 	<p>L</p> <p>2 PCS</p>	<p>L-1 L-2</p> 
<p>M</p> <p>4 PCS</p>		<p>N</p> <p>8 PCS</p>	<p>N-1 N-2</p> 	<p>O</p> <p>3 PCS</p>	<p>O-1 O-2</p> 	<p>P</p> <p>3 PCS</p>	
<p>Q</p> <p>1 PCS</p>		<p>R</p> <p>5 PCS</p>		<p>S</p> <p>5 PCS</p>		<p>T</p> <p>6 PCS</p>	

PARTS LIST

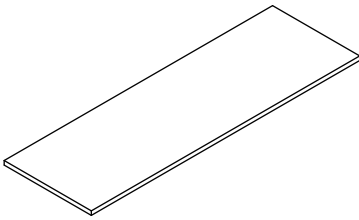

1- 1PCS

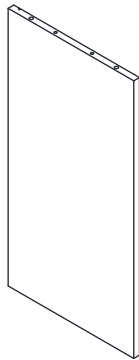

2- 1PCS

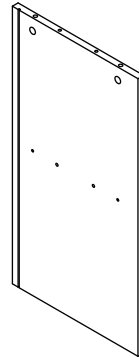

3- 1PCS

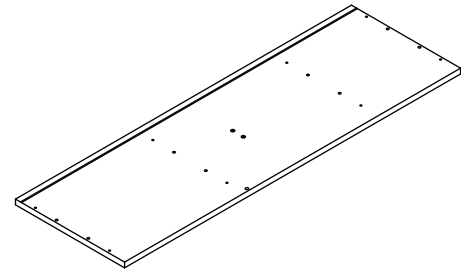

4- 1PCS

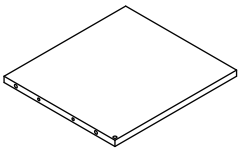

5- 1PCS

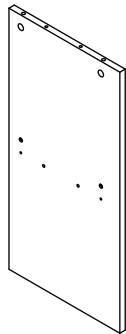

6- 1PCS

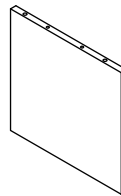

7- 1PCS

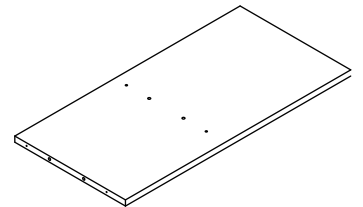

8- 1PCS

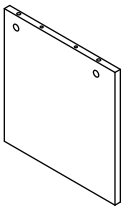

9- 1PCS



10- 1PCS

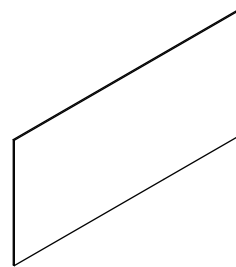

11- 1PCS

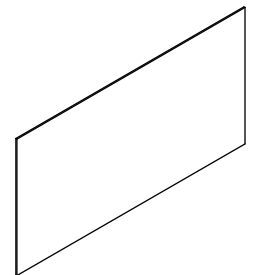

12- 1PCS



13- 2PCS

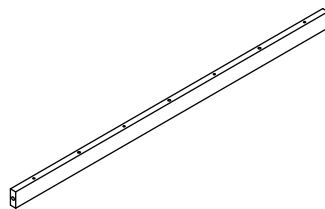

14- 2PCS



15- 2PCS

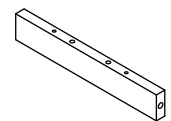

16- 2PCS

PARTS LIST



17- 1PCS

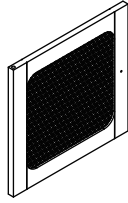

18- 1PCS

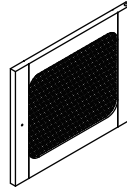

19- 1PCS

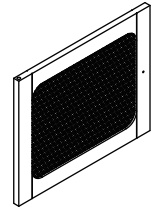

20- 1PCS

ASSEMBLY STEPS

STEP 1.

Fix magnetic door catch (O-1) to part 8 using screws (O-2), as shown. Insert quickfit screws (A) into part 8, as shown.

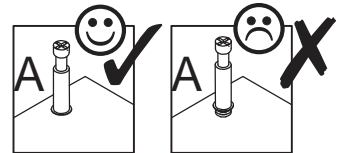
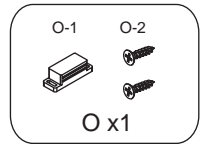
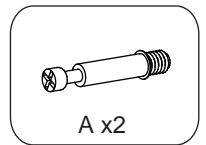
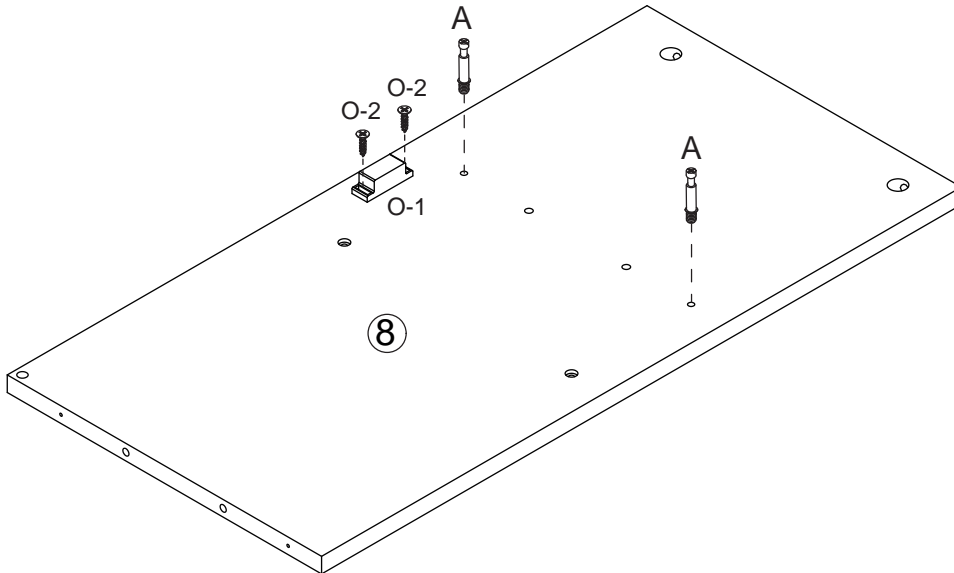

STEP 2.

Fix parts 6 and 7 to part 8 with wooden dowels (C) and screws (D), as shown.

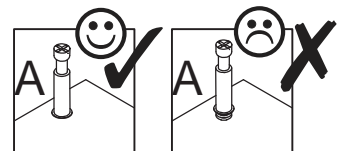
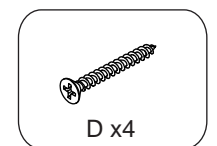
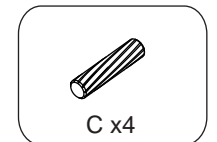
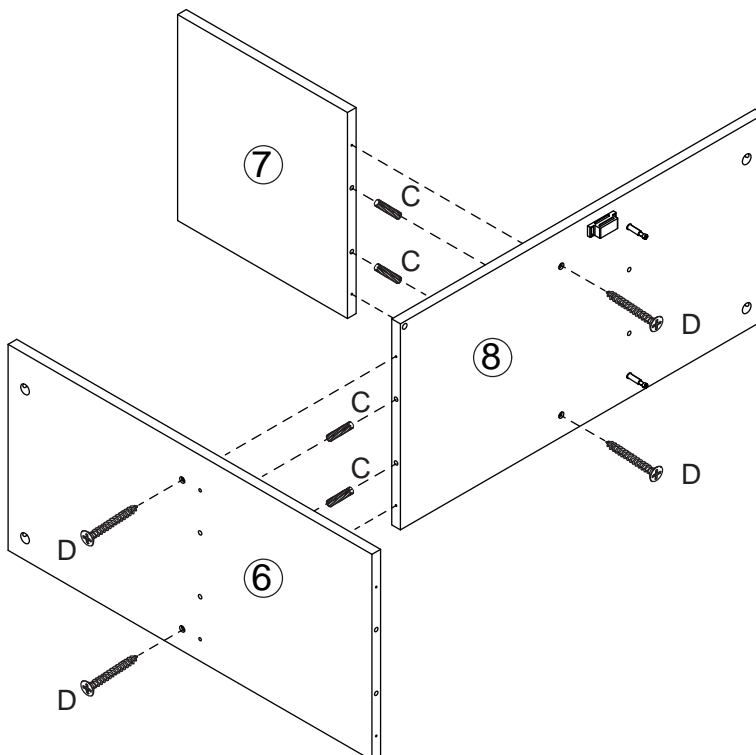

ASSEMBLY STEPS

STEP 3.

Fix part 5 to part 6 using wooden dowels (C) and screws (D), as shown.

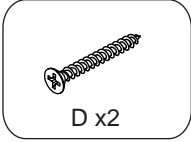
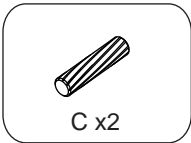
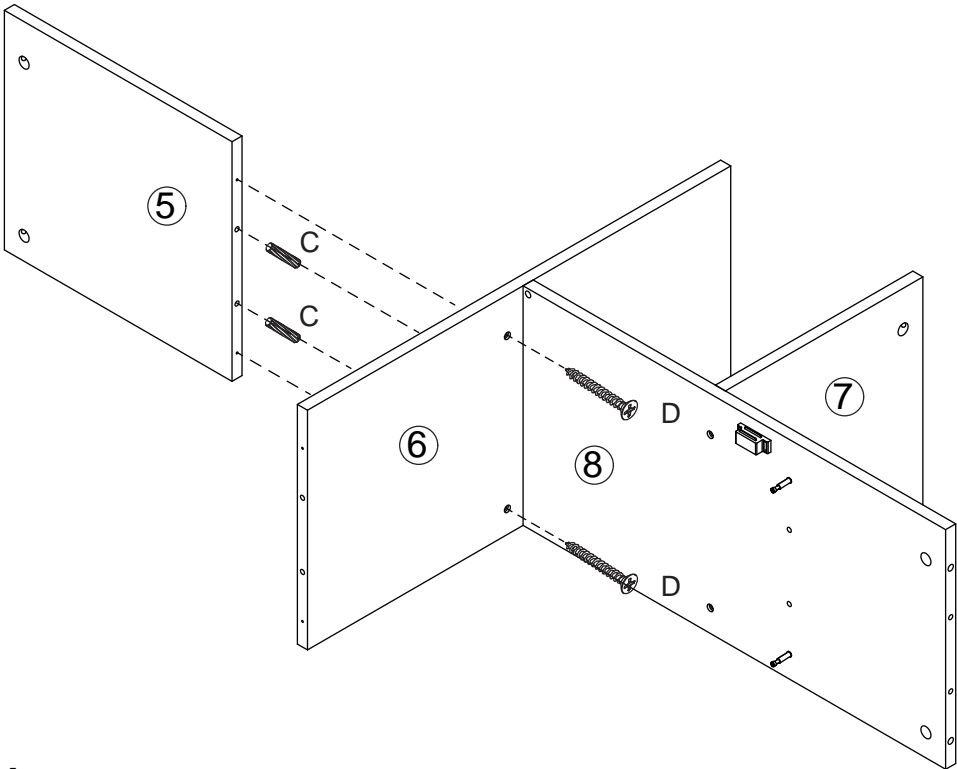

STEP 4.

Insert cam locks (B) and wooden dowels (C) into part 9, as shown.

Fit part 9 to part 8.

Turn cam locks clockwise to tighten.

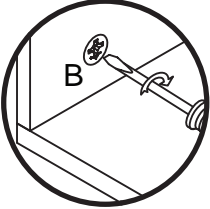
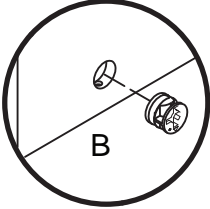
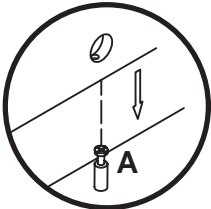
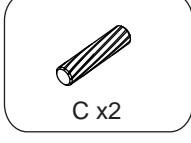
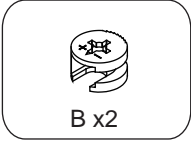
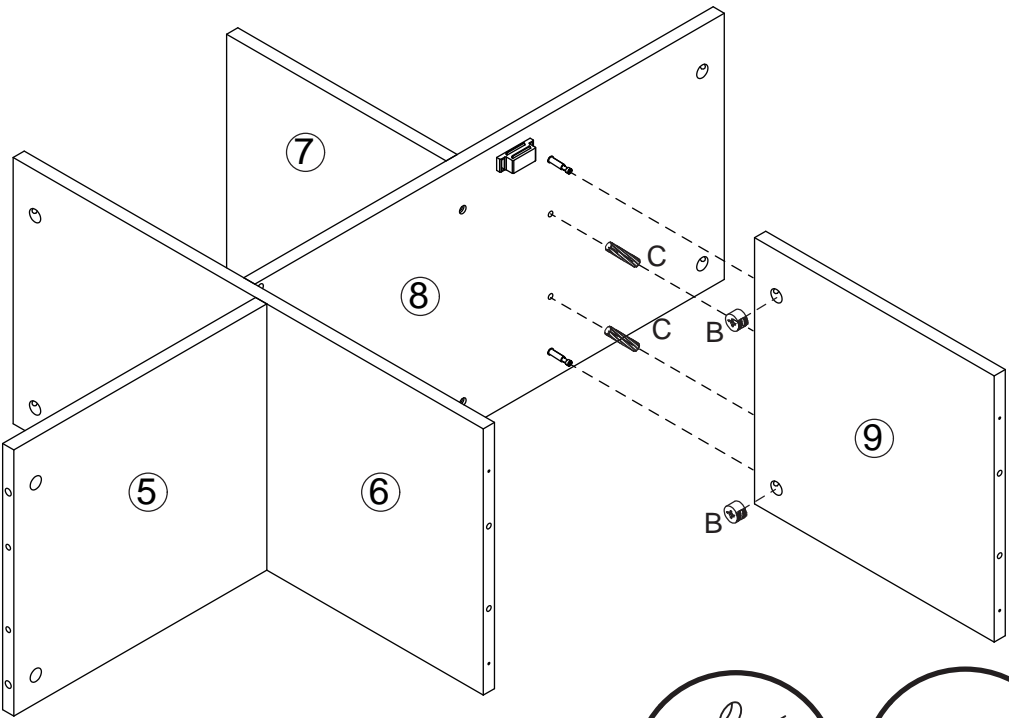

ASSEMBLY STEPS

STEP 5.

Insert quickfit screws (A) into parts 2 and 3, as shown.

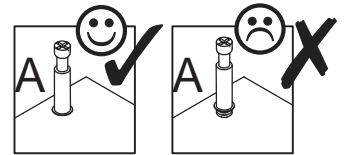
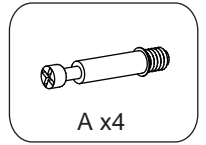
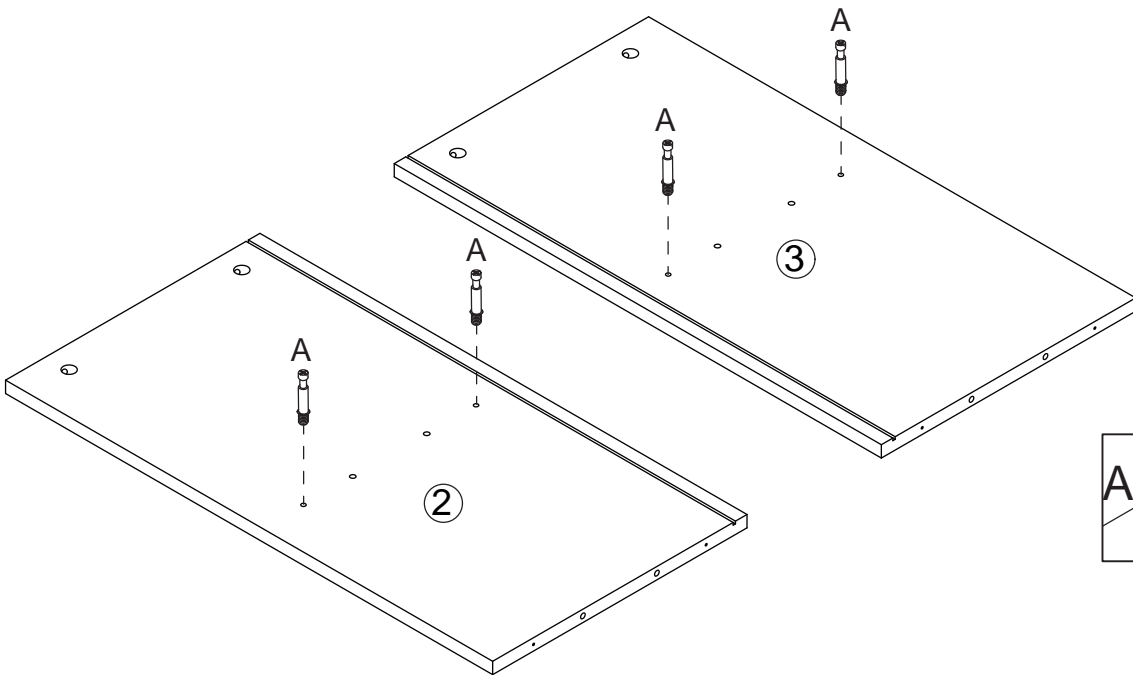

STEP 6.

Insert cam locks (B) and wooden dowels (C) into parts 5 and 8, as shown.
Fit parts 2 and 3 to parts 5 and 8, as shown.
Turn cam locks clockwise to tighten.

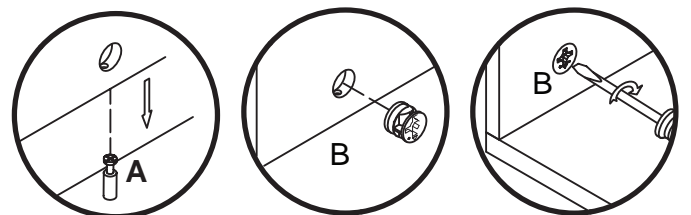
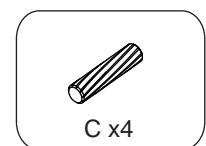
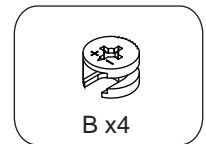
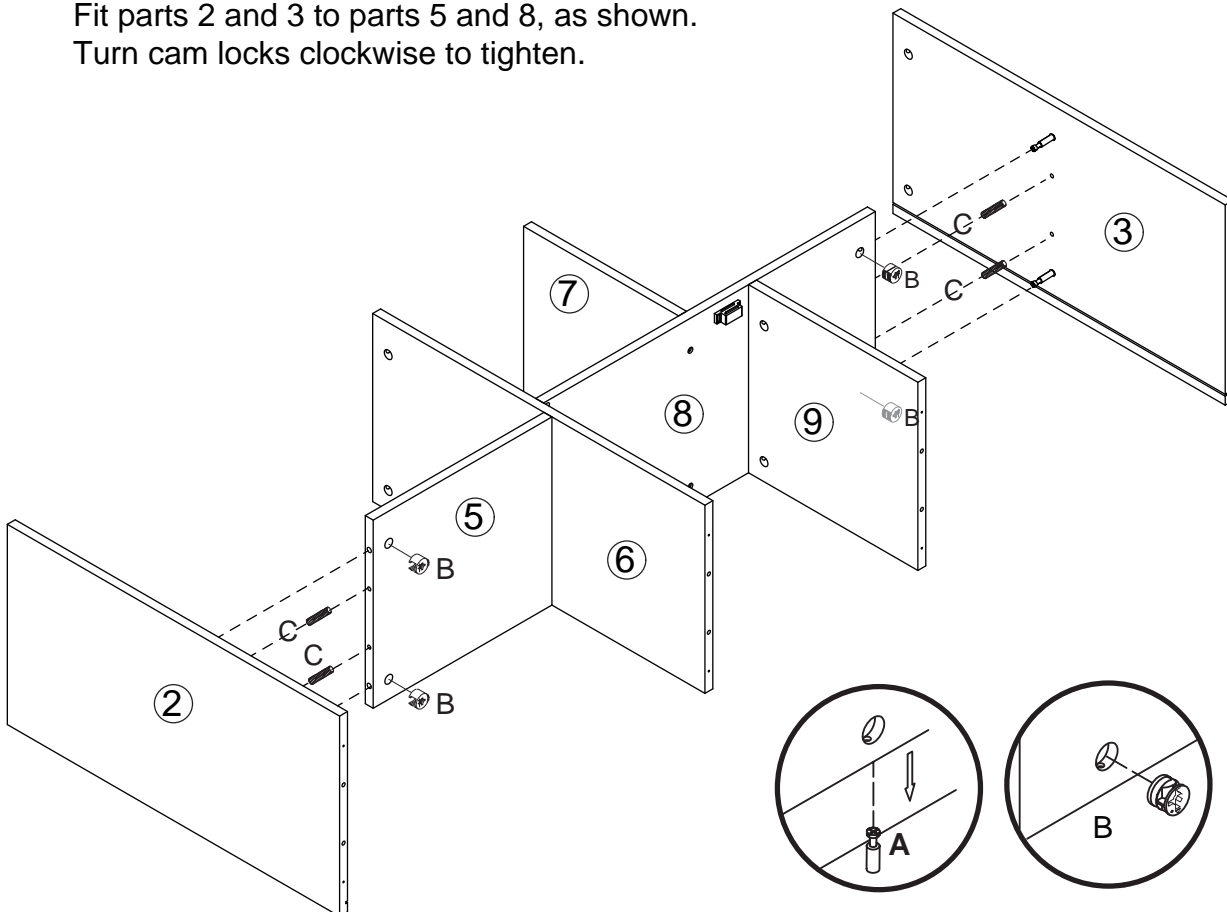

ASSEMBLY STEPS

STEP 7.

Fix part 17 to part 4 using screws (D), as shown.

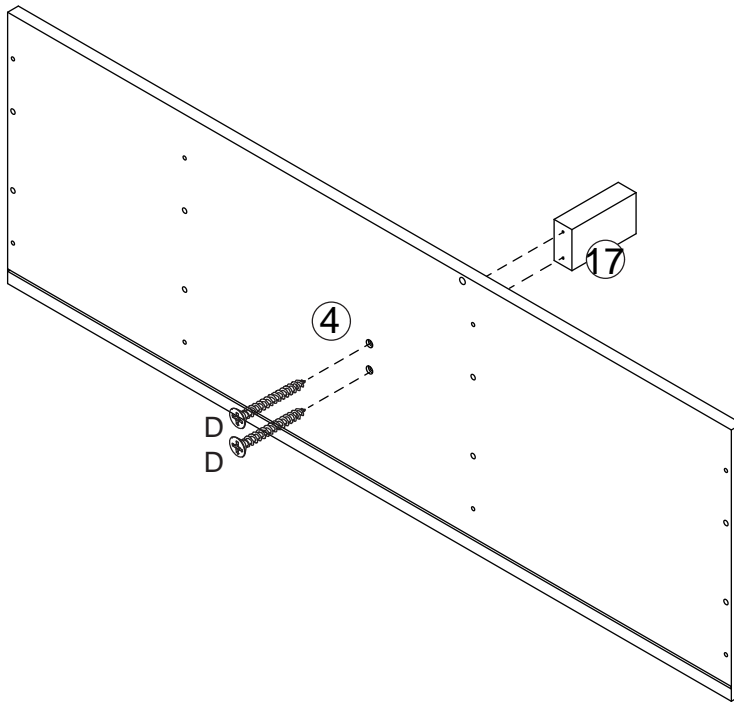
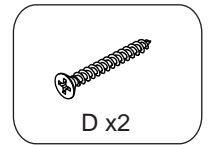

STEP 8.

Insert wooden dowels (C) into parts 2, 6, 9 and 3 and attach to part 4 using screws (D), as shown.

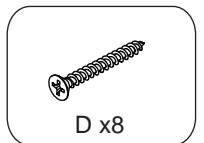
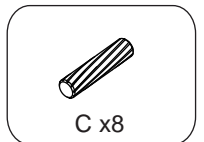
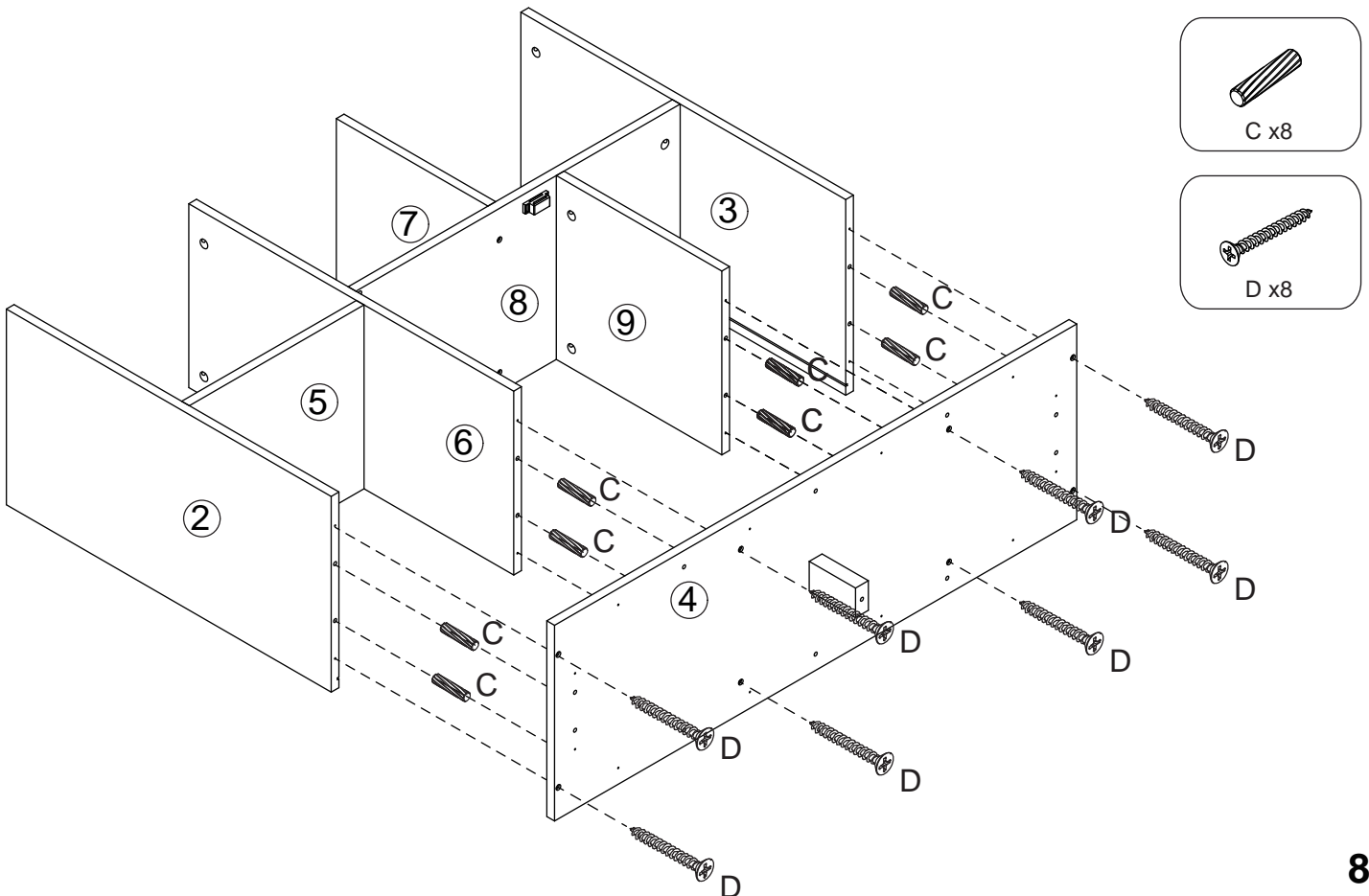

ASSEMBLY STEPS

STEP 9. x2

Insert quickfit screws (A) into parts 13 and 15, as shown.

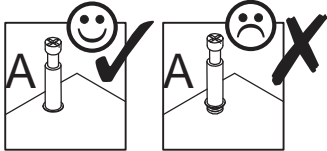
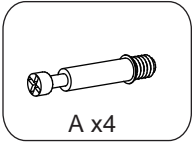
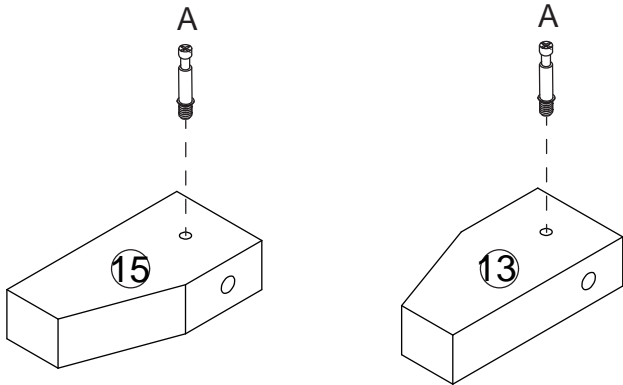

STEP 10. x2

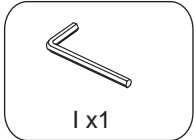
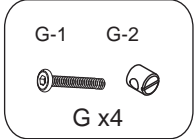
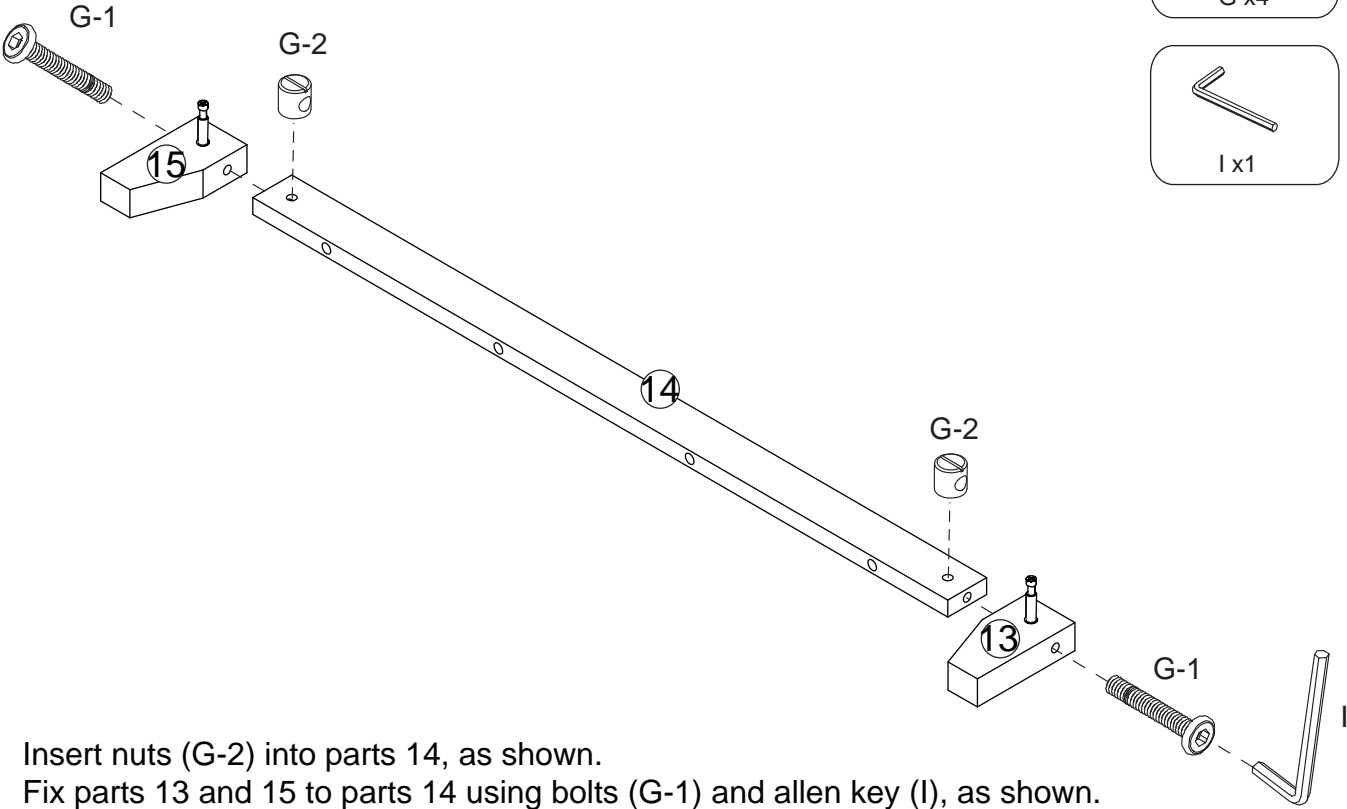

Insert nuts (G-2) into parts 14, as shown.
Fix parts 13 and 15 to parts 14 using bolts (G-1) and allen key (I), as shown.

ASSEMBLY STEPS

STEP 11.

Insert cam locks (B) into parts 16.
Fit parts 13 and 15 to parts 16, as shown.
Turn cam locks clockwise to tighten.

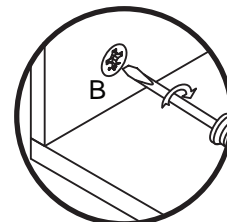
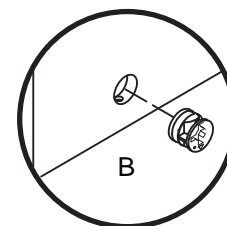
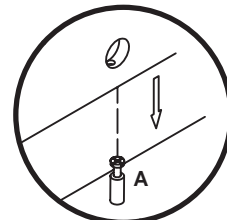
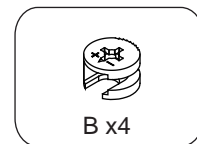
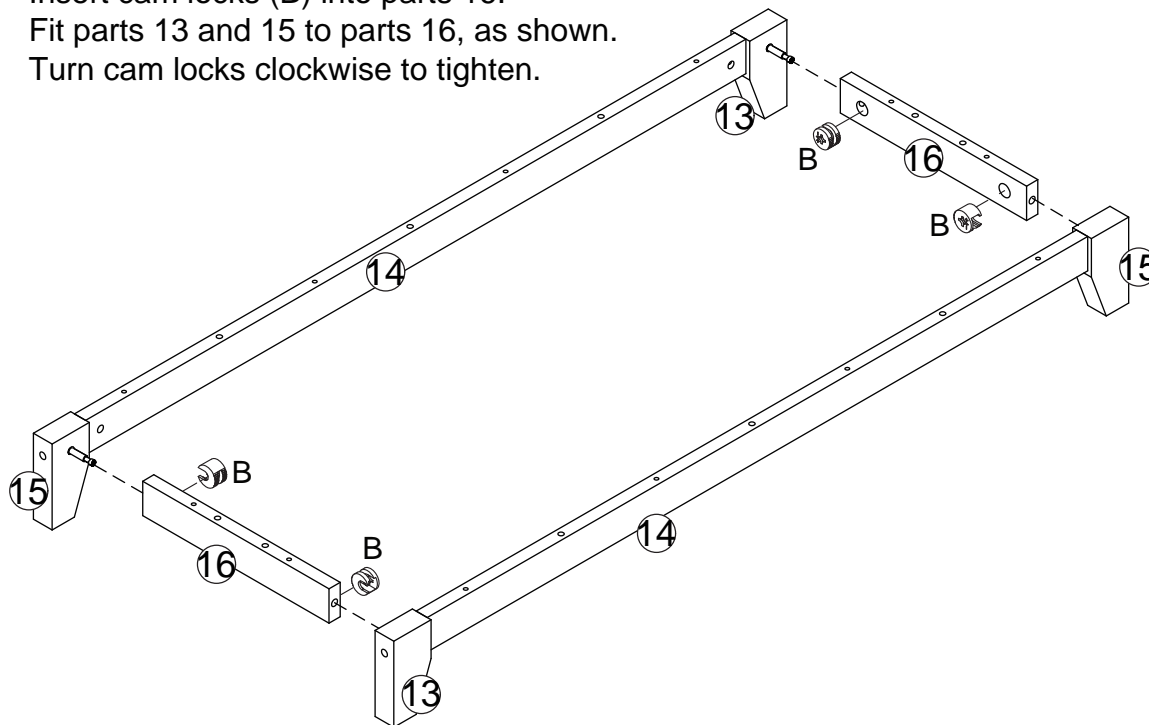

STEP 12.

Insert wooden dowels (C) into part 14 and 16, as shown.
Attach screw covers (M) to the legs, as shown.

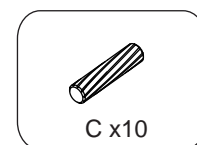
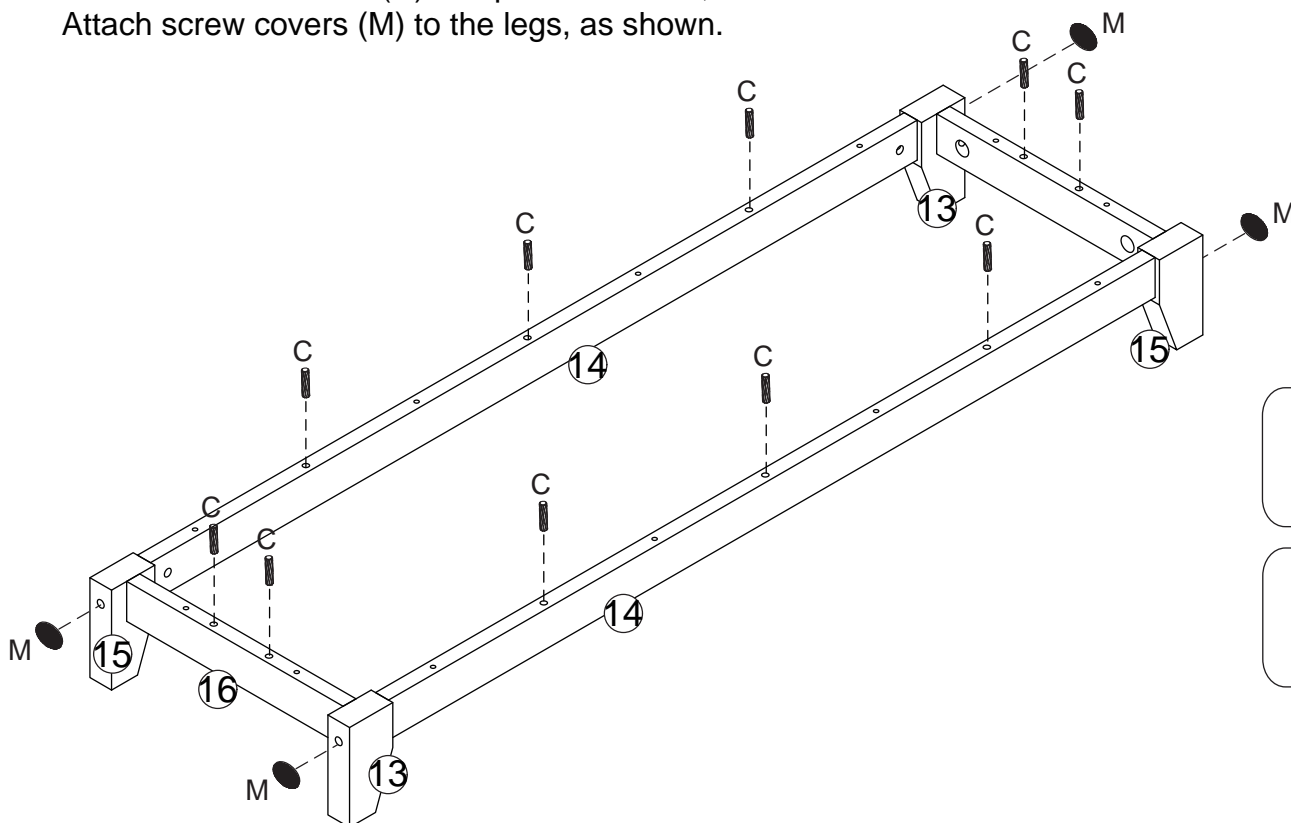

ASSEMBLY STEPS

STEP 13.

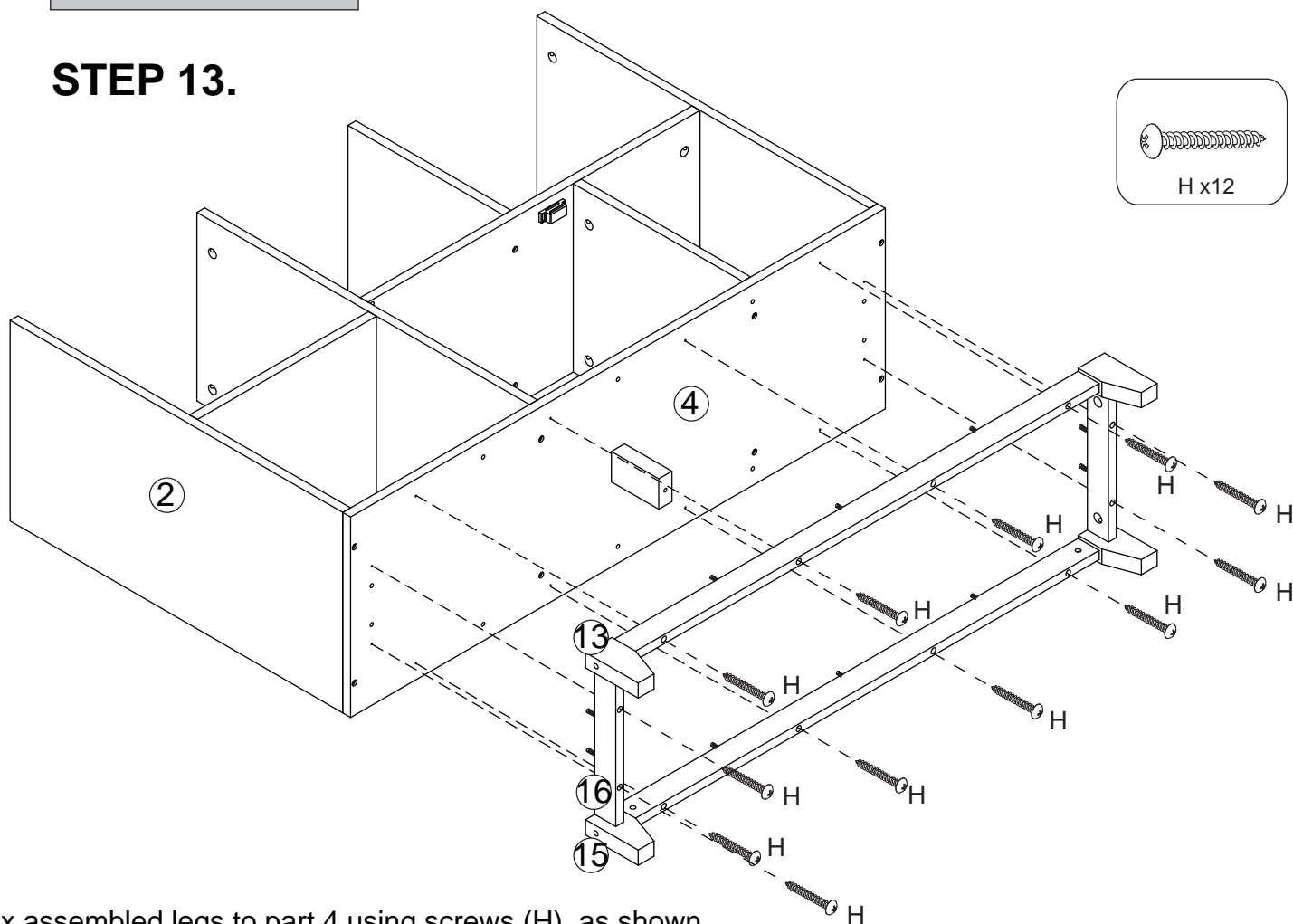

Fix assembled legs to part 4 using screws (H), as shown.

STEP 14.

Fix foot nails (J) to legs 13 and 15, as shown.
Fix foot nails (Q) to leg 17, as shown.

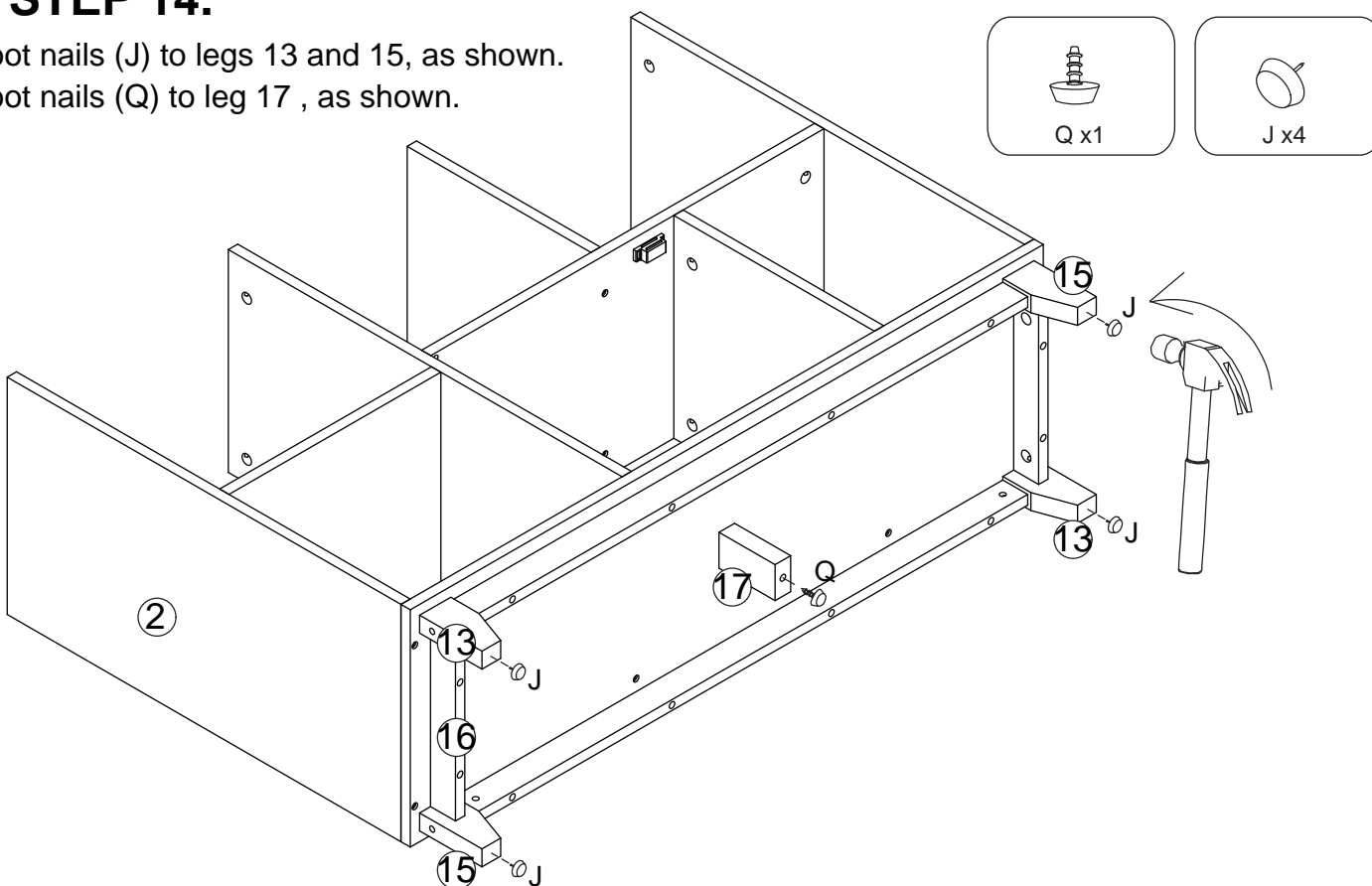

ASSEMBLY STEPS

STEP 15.

Insert part 10 into grooves between parts 2 and 4, as shown.
Insert part 12 into grooves between parts 3 and 4, as shown.

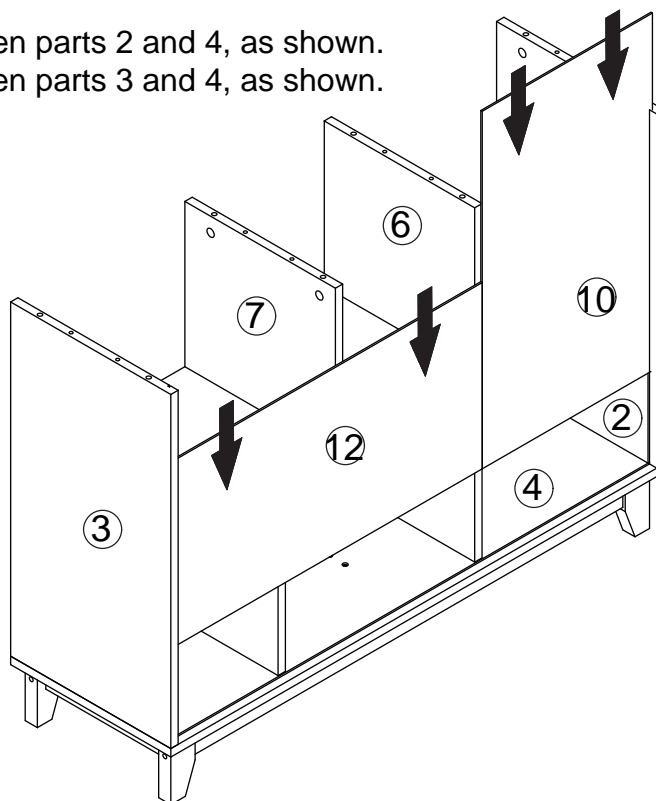

STEP 16.

Fix connecting braces (R) to connected parts 10 and 12 using screws (s), as shown.

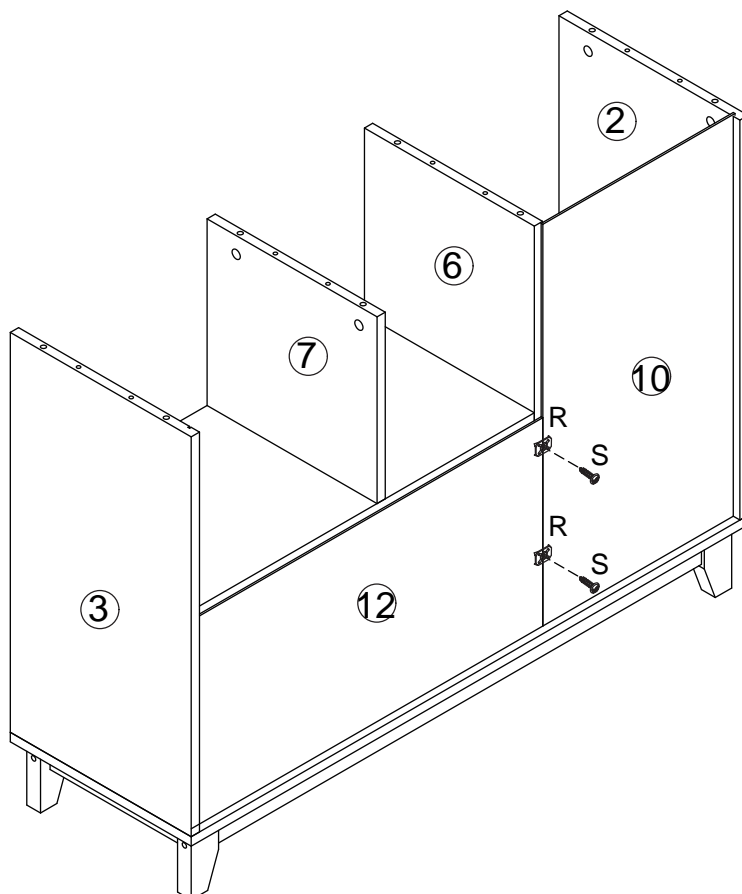

R x2



S x2

ASSEMBLY STEPS

STEP 17.

Insert part 11 into groove of part 3, as shown.

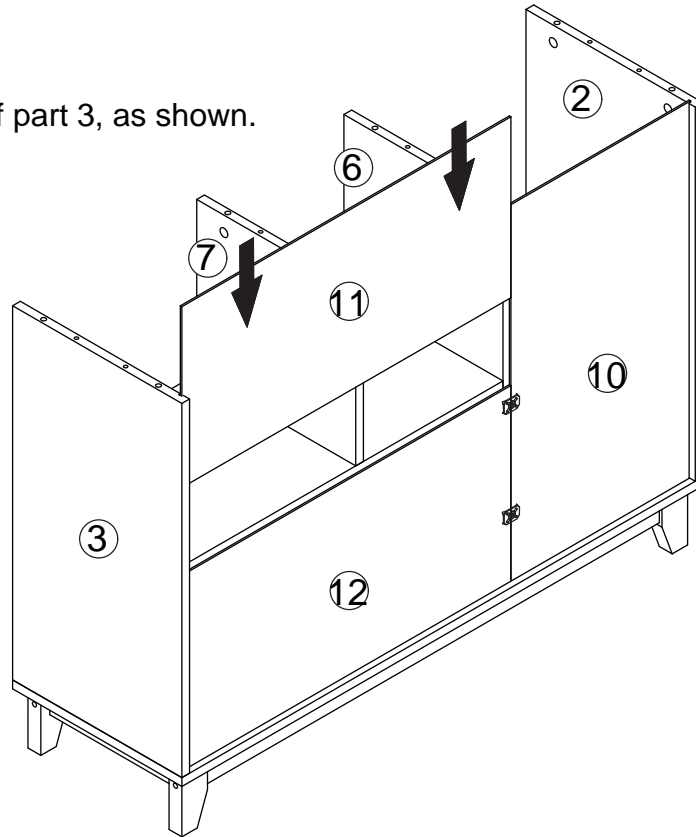

STEP 18.

Fix connecting braces (R) to connected parts 11, 12 and 10 using screws (s), as shown.

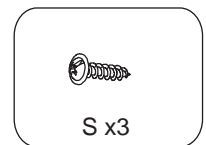
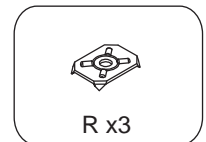
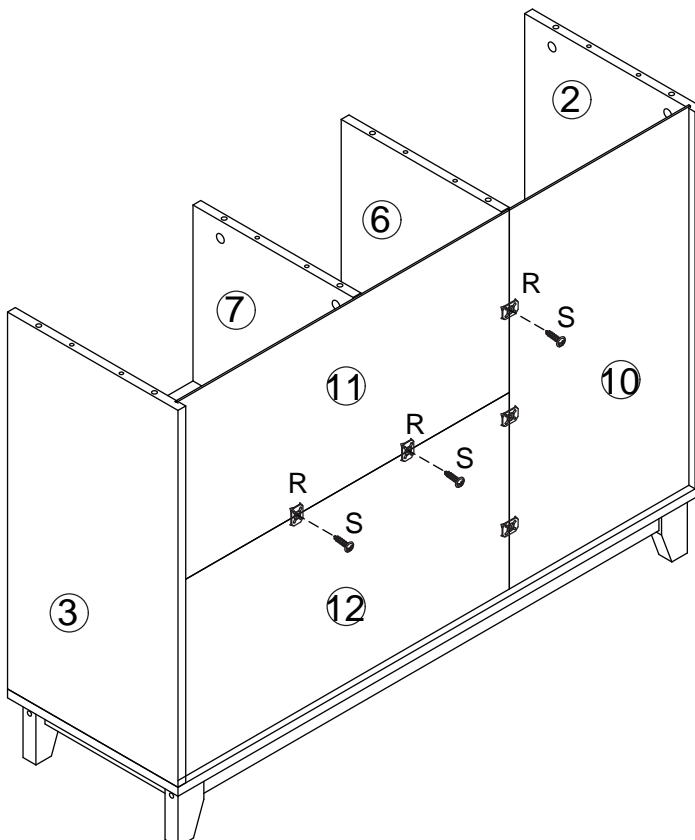

ASSEMBLY STEPS

STEP 19.

Fix magnetic door catch (O-1) to part 1 using screws (O-2), as shown.
Fit quickfit screws (A) into part 1, as shown.

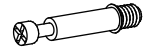

A x8

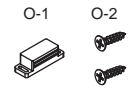

O x2

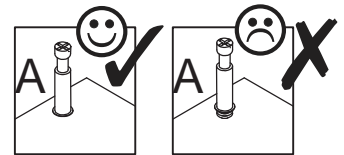
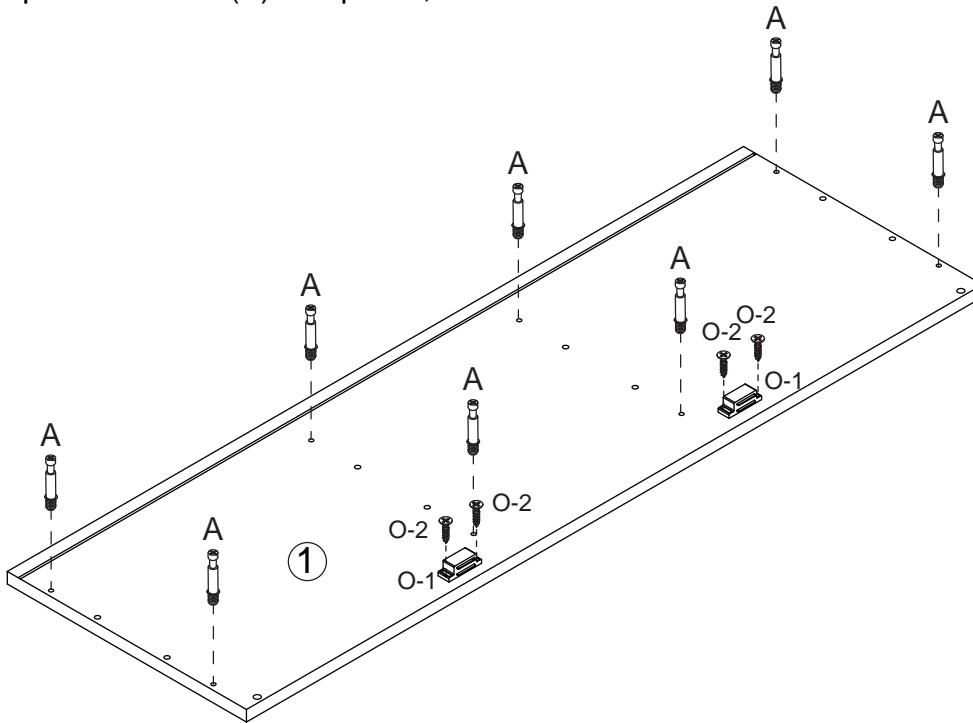

STEP 20.

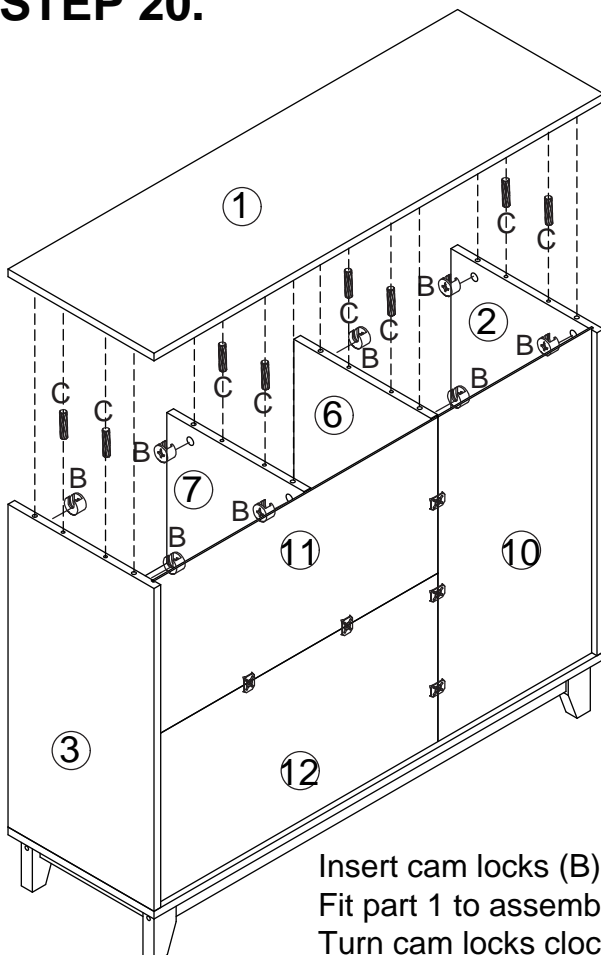

B x8



C x8

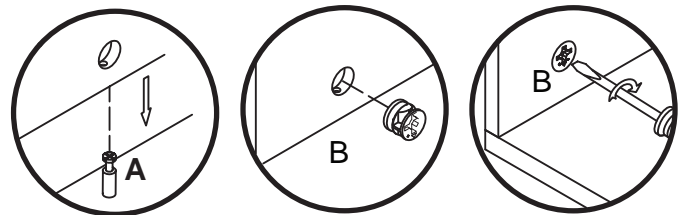

Insert cam locks (B) and wooden dowels (C) into parts 2, 6, 7 and 3, as shown.
Fit part 1 to assembled unit, as shown.
Turn cam locks clockwise to tighten.

ASSEMBLY STEPS

STEP 21.

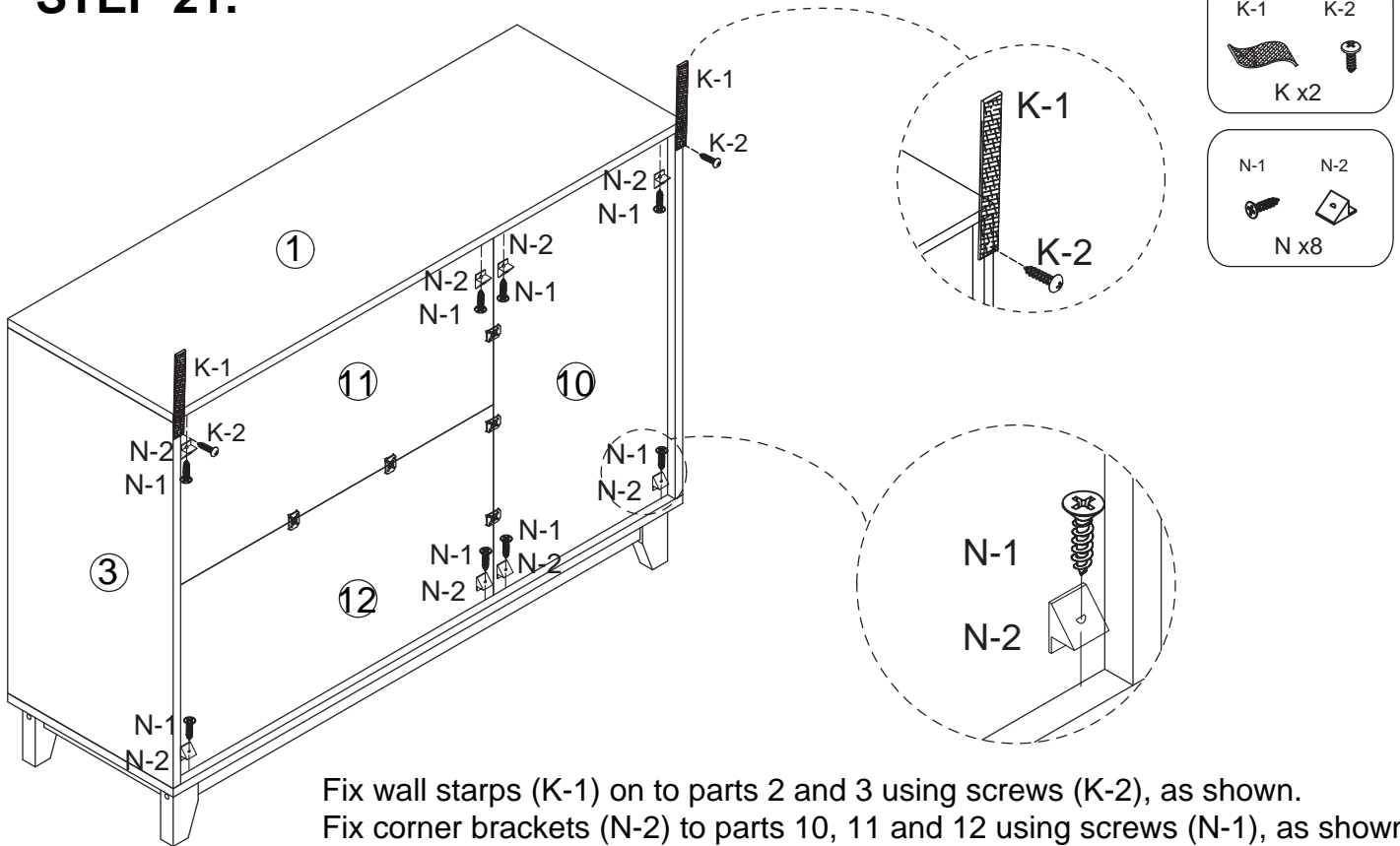

Fix wall stirrups (K-1) on to parts 2 and 3 using screws (K-2), as shown.
Fix corner brackets (N-2) to parts 10, 11 and 12 using screws (N-1), as shown.

STEP 22.

Fix handles (F-2) to doors 18, 19 and 20 using screws (F-1), as shown.
Fix door catches to doors 18, 19 and 20 using screws (E), as shown.
Insert bearings (T) into doors 18, 19 and 20, as shown.

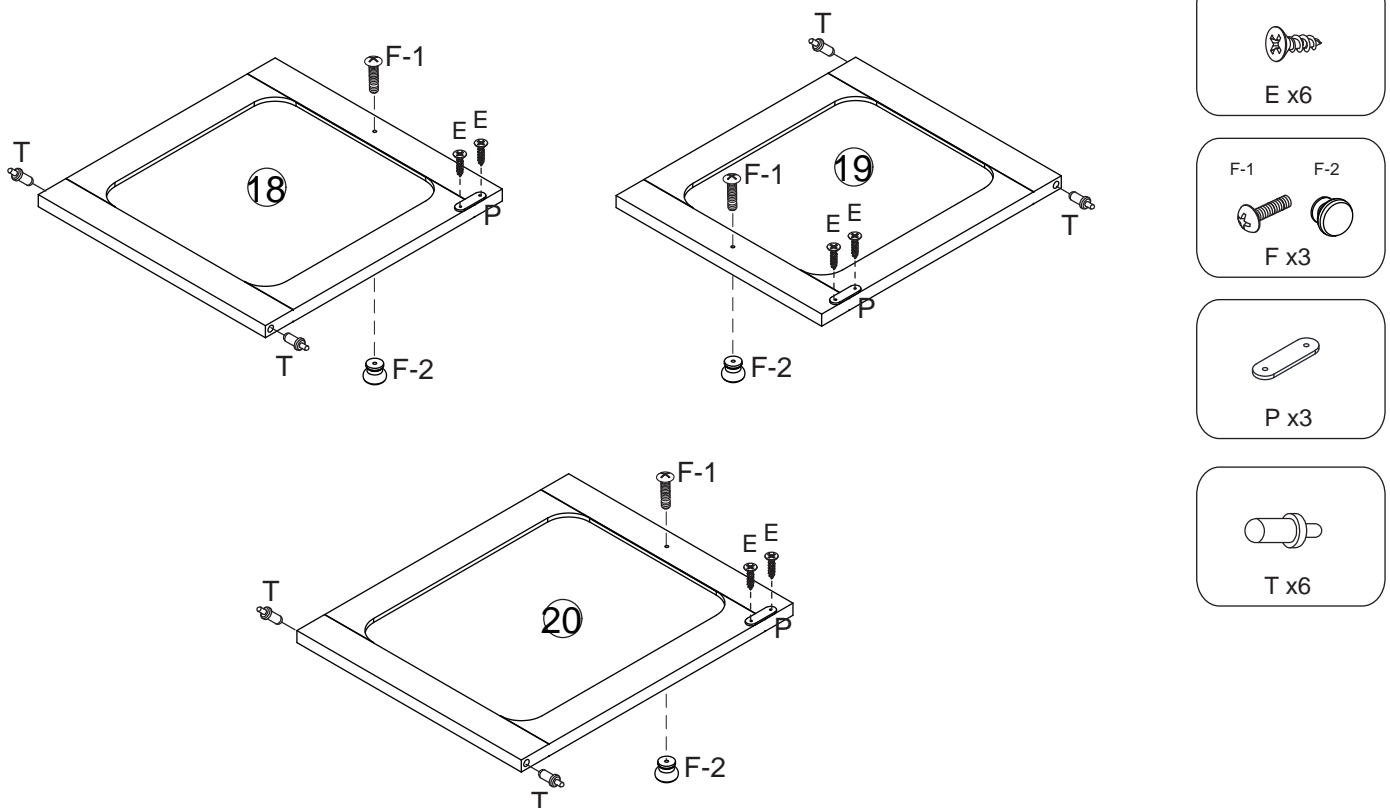

ASSEMBLY STEPS

STEP 23.

Press down breaing and fit doors 18, 19 and 20 into assembled unit, as shown.

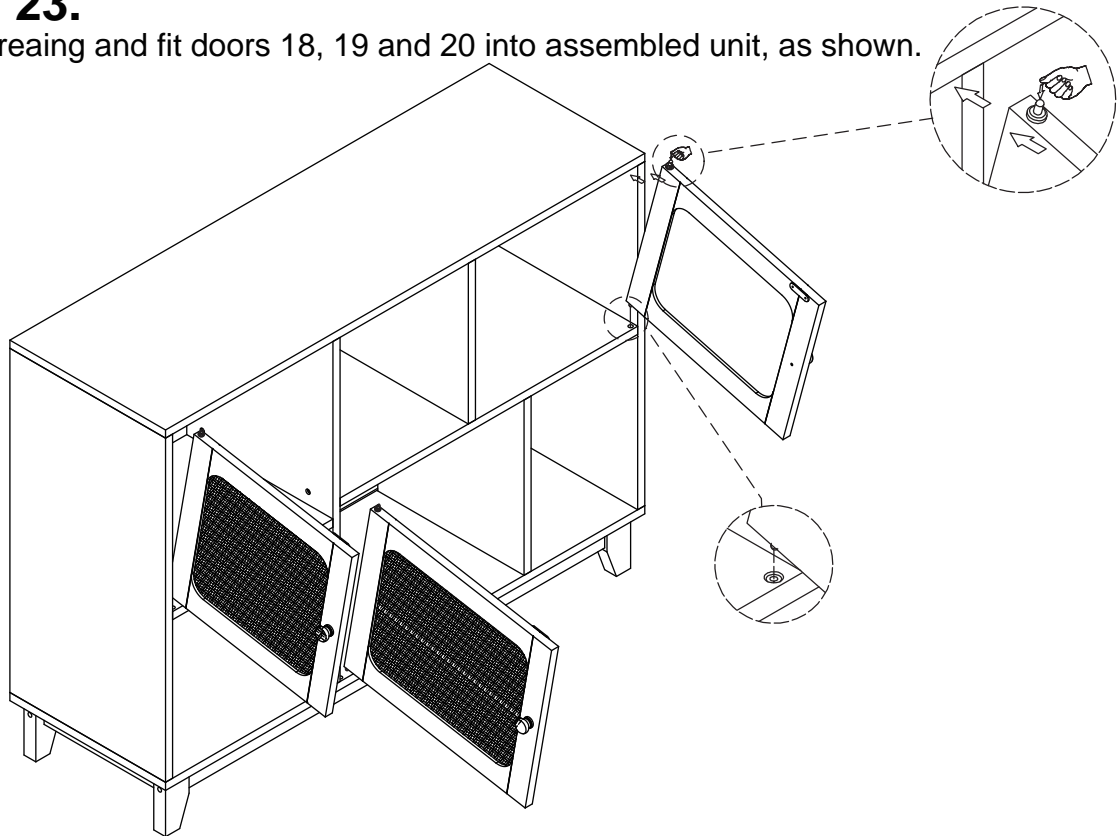

STEP 24.

For extra stability, you must fix your sideboard to the wall using hardware (L-1 and L-2), as shown. Screws (L-2) are fixed through wall straps and into the wall plugs (L-1). Should you choose not to affix the product to the wall, serious injury may be caused if the product tips over.

