

ASSEMBLY INSTRUCTION

MODEL: 11018 HUA BAR CHAIR

Read this instruction carefully. Remove all wrapping material, staples and straps from the carton. See hardware and furniture part list for guidance. Be sure you have all wooden furniture parts on a clean and flat soft surface, such as a carpet or rug, to prevent from being scratched.

CAUTION :

1. Do Not FULLY - TIGHTEN the nut or screw until all is ready to assemble.
2. Do Not OVER - TIGHTEN the nut or screw to avoid causing damages to the tread.
3. Keep all hardware part out reach of children.

Part List

| No. | Description | Qty. |
|-----|-------------------|-------|
| A | Seat | 1 pc |
| B | Chair Leg R/L | 2 pcs |
| C | Stretcher (Short) | 2 pcs |
| D | Stretcher (Long) | 2 pcs |

Hardware List

| No. | Description | Qty. |
|-----|----------------------|--------|
| 1 | JCBC M6 x 40mm | 8 pcs |
| 2 | JCBC M6 x 50mm | 4 pcs |
| 3 | Spring Washer M6 | 12 pcs |
| 4 | Allen Key M4 x 110mm | 1 pc |

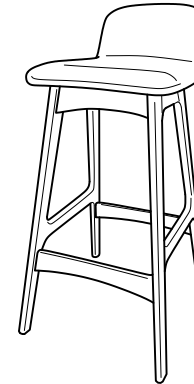

Step 1

Install item (C) and (D) after identified the front leg. Make sure to install item (C) as level as item (B).

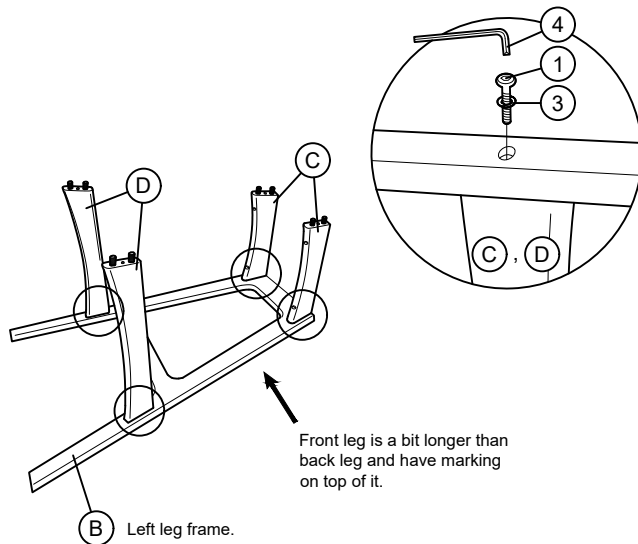

Step 2

Install another side of Item (B).

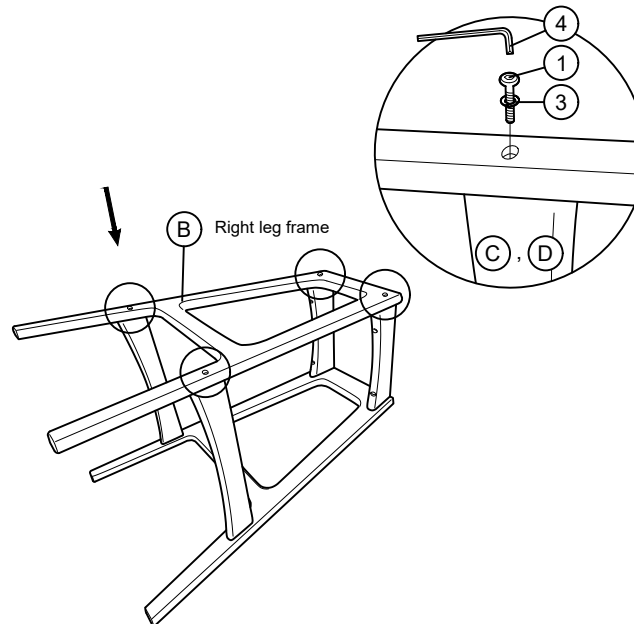

Step 3

