

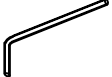





Assembly Instructions

Model : CT-8003

Part List			Hardware		
		QTY			QTY
1	Top Panel	1	A	Allen Key M4 	1
2	Right Side Panel	1	B	Wood Dowel 	20
3	Left Side Panel 1	1	C	Mini Fix Bolt 	20
4	Left Side Panel 2	1	D	Mini Fix Housing 	20
5	Bottom Panel	1	E	Mini Fix Cap 	20
6	Middle Panel Support	1	F	White Nail Leg 	6
7	Middle Panel	1			

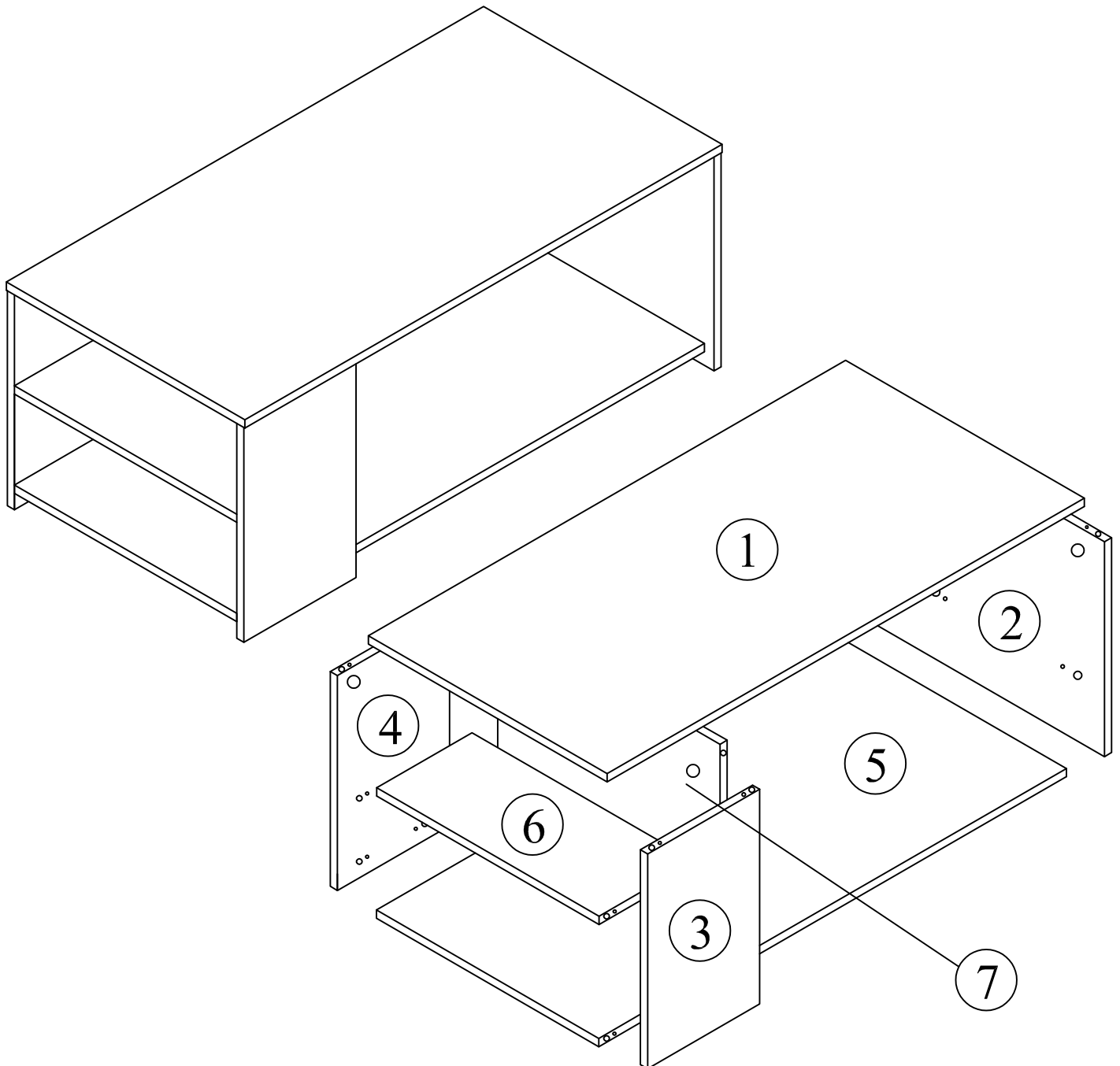

Step 1

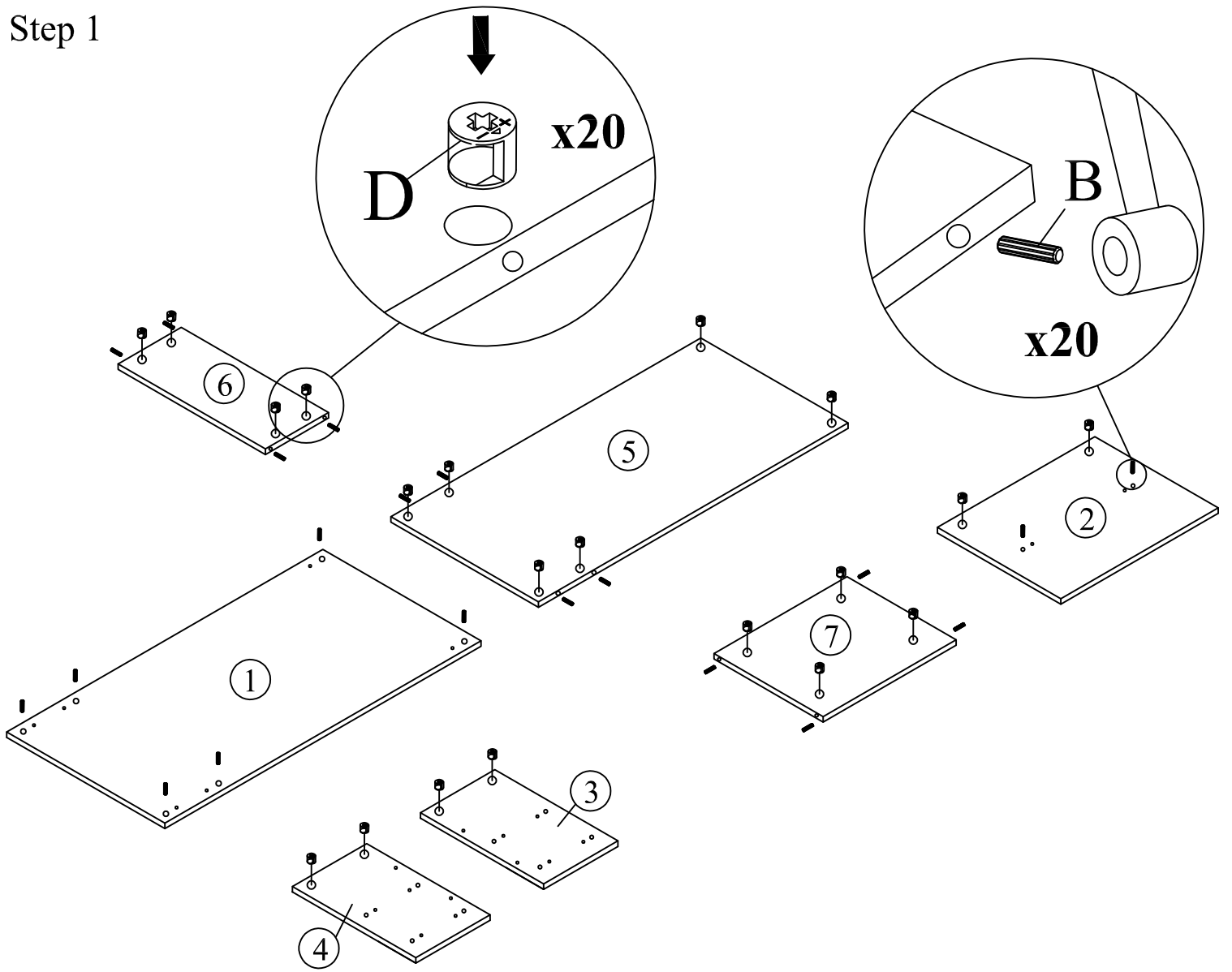

Step 2

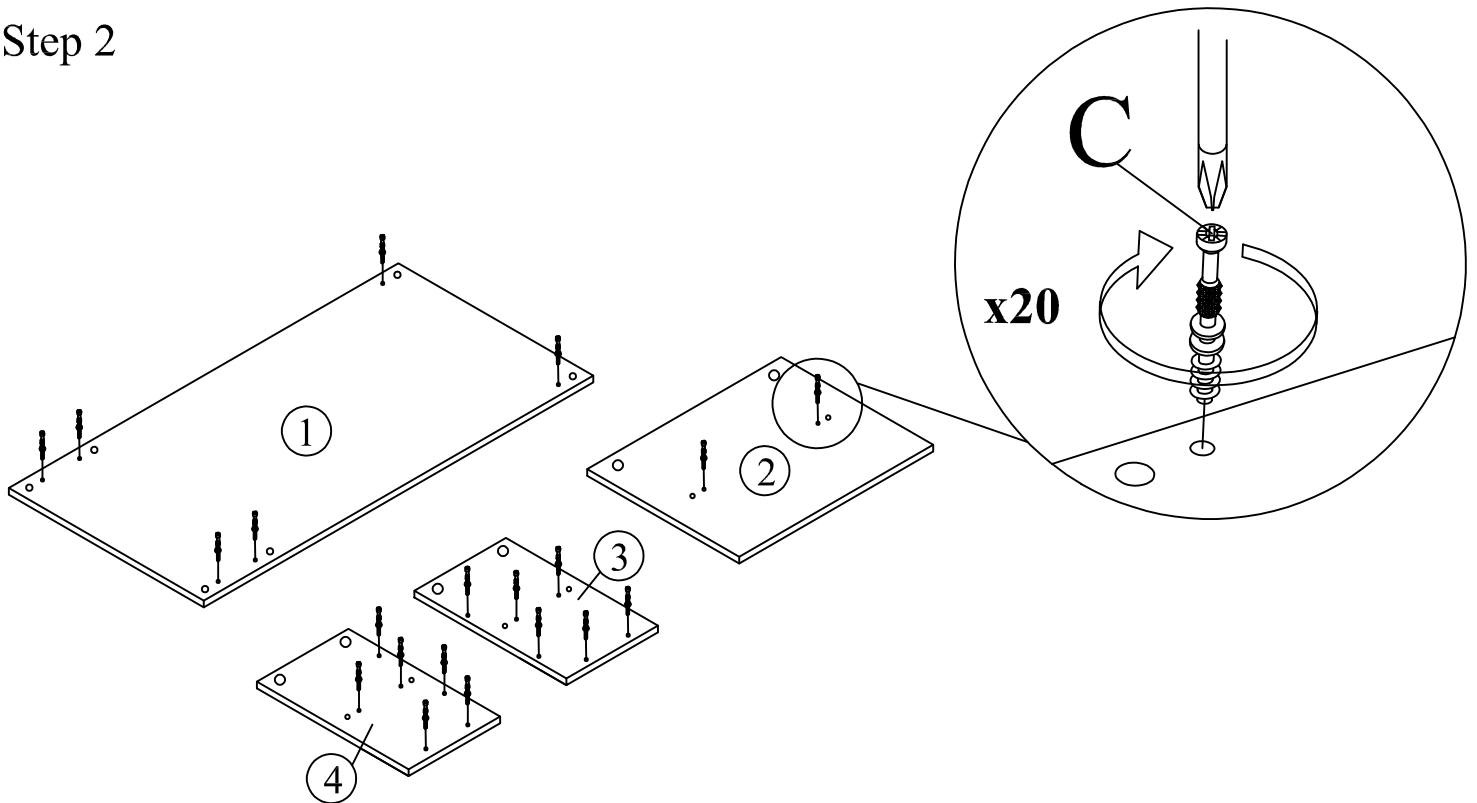

Step 3

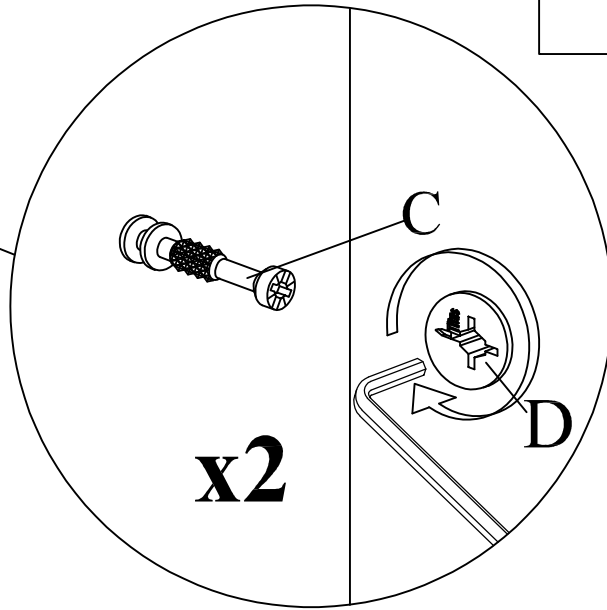
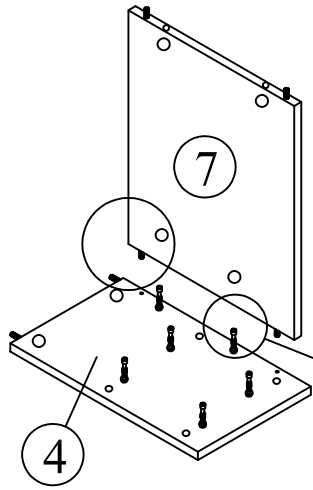

This is how a mini fix works...

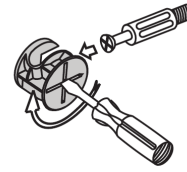

The head of the mini fix housing goes into the open mouth of the mini fix bolt. You then turn the mini fix housing so it tightens over the mini fix bolt.

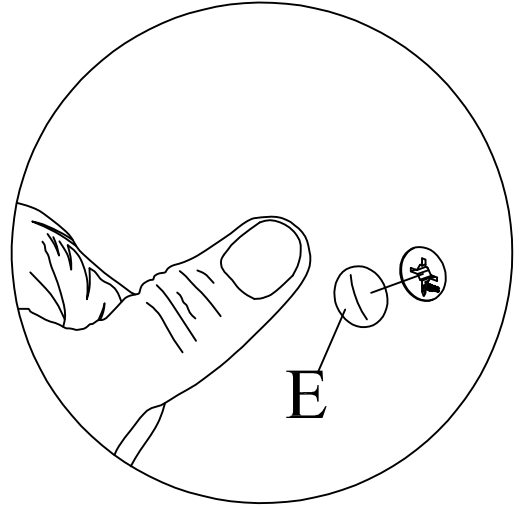

****Attach Minifix Cap as shown.***

Step 4

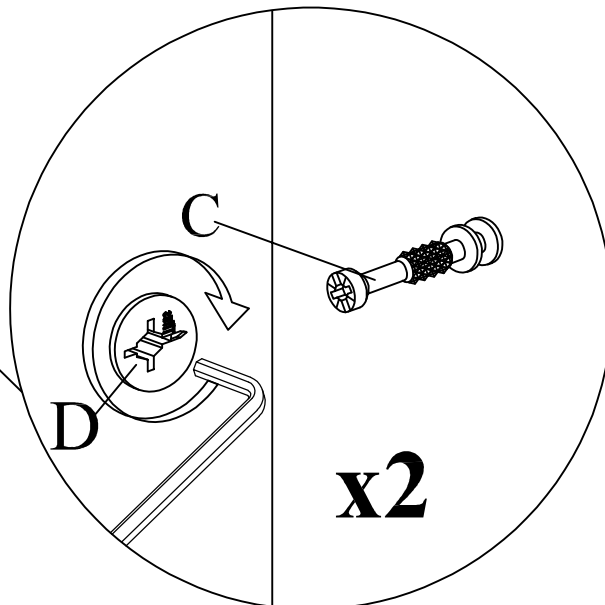
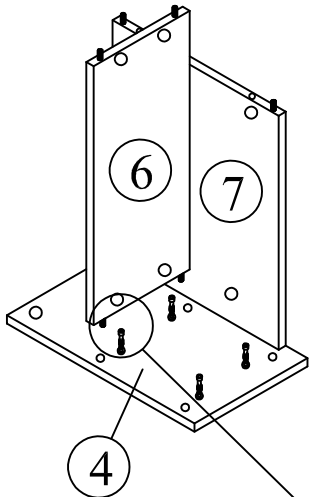

This is how a mini fix works...

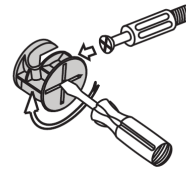

The head of the mini fix housing goes into the open mouth of the mini fix bolt. You then turn the mini fix housing so it tightens over the mini fix bolt.

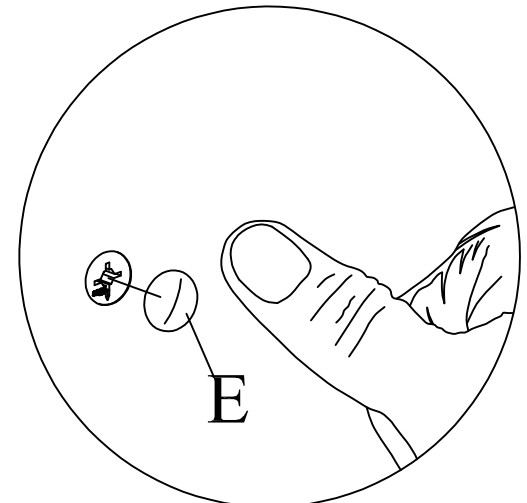

****Attach Minifix Cap as shown.***

Step 5

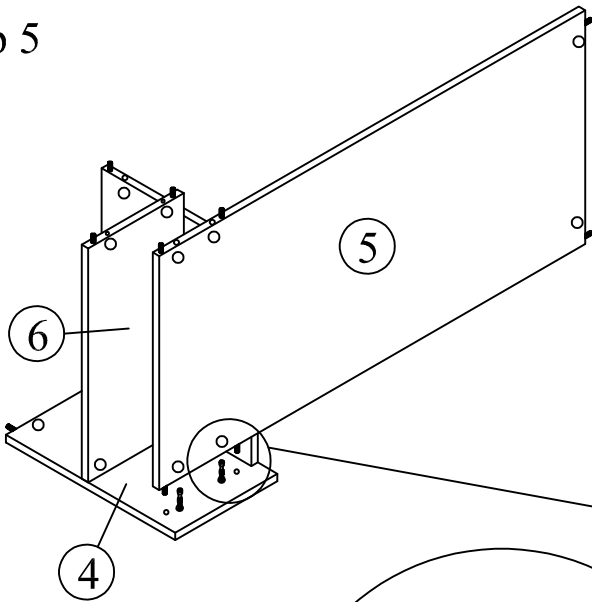

This is how a mini fix works...

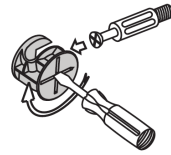

The head of the mini fix housing goes into the open mouth of the mini fix bolt. You then turn the mini fix housing so it tightens over the mini fix bolt.

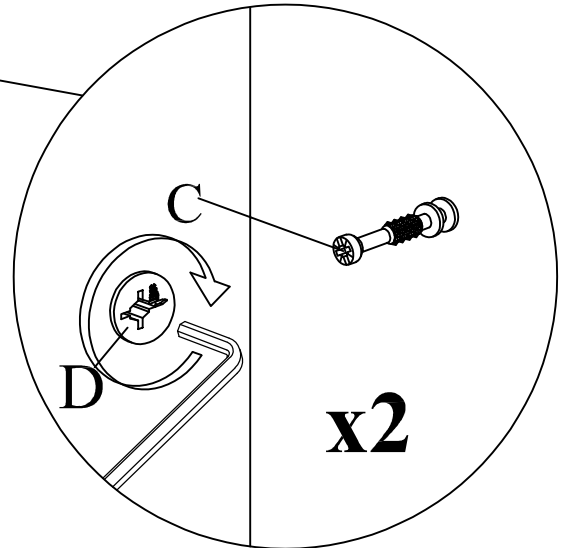
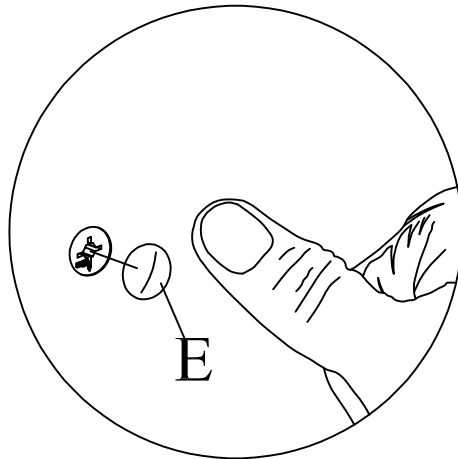

****Attach Minifix Cap as shown.***

Step 6

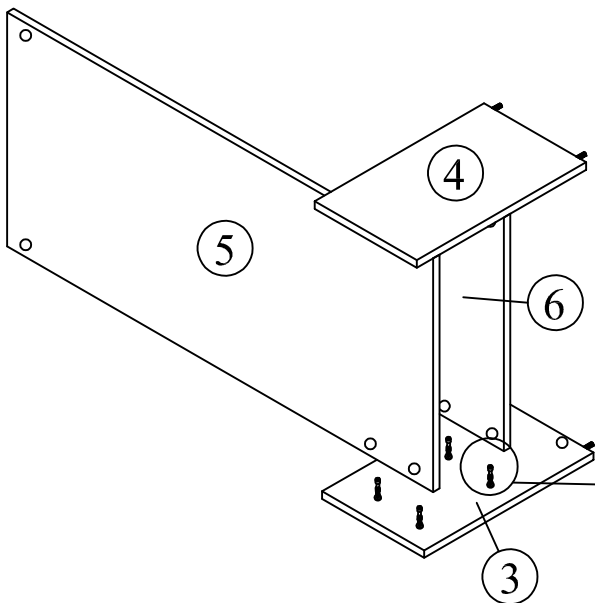

This is how a mini fix works...

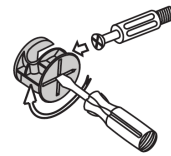

The head of the mini fix housing goes into the open mouth of the mini fix bolt. You then turn the mini fix housing so it tightens over the mini fix bolt.

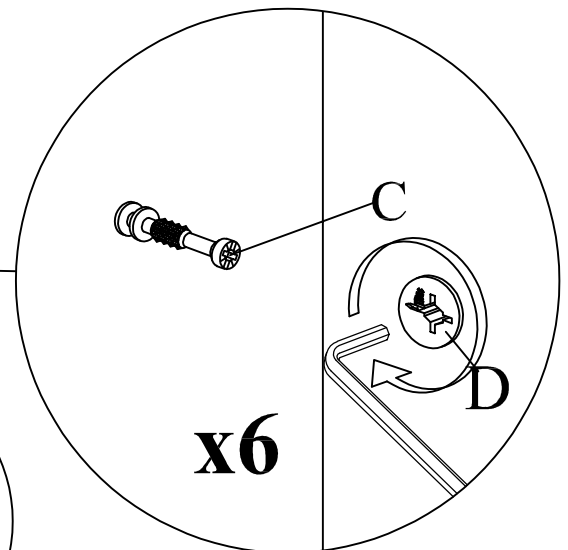
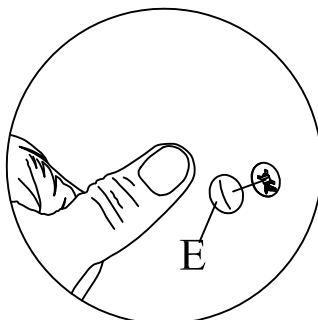

****Attach Minifix Cap as shown.***

Step 7

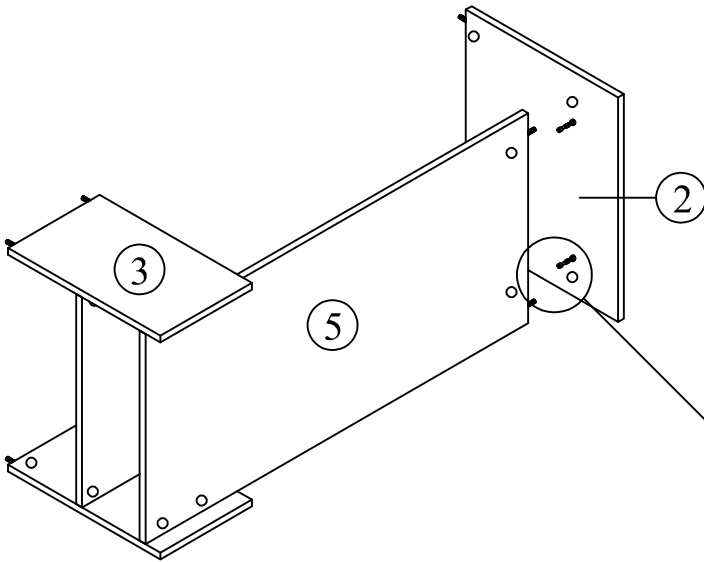

This is how a mini fix works...

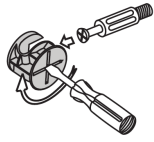

The head of the mini fix housing goes into the open mouth of the mini fix bolt. You then turn the mini fix housing so it tightens over the mini fix bolt.

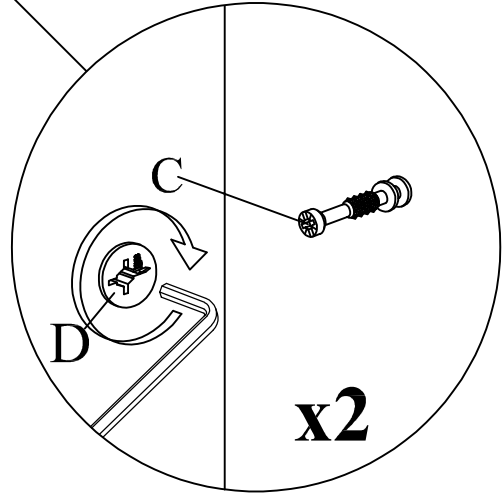

**Attach Minifix Cap as shown.*

Step 8

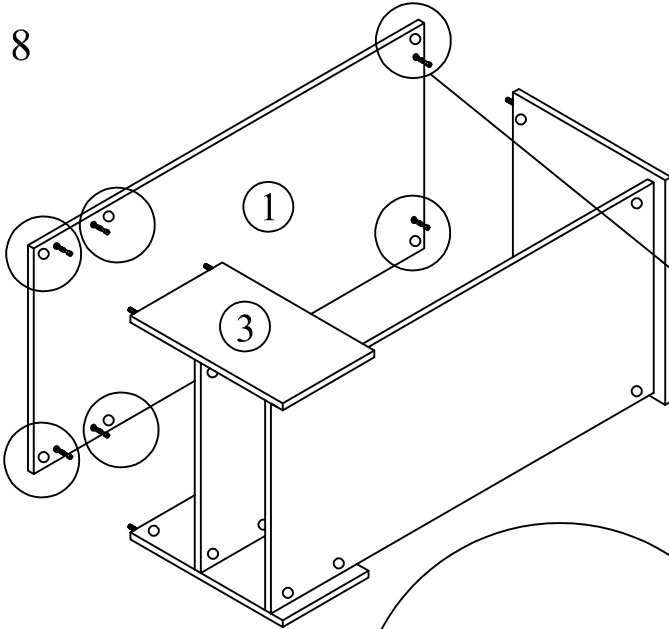

This is how a mini fix works...

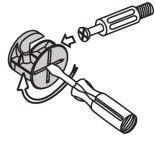

The head of the mini fix housing goes into the open mouth of the mini fix bolt. You then turn the mini fix housing so it tightens over the mini fix bolt.

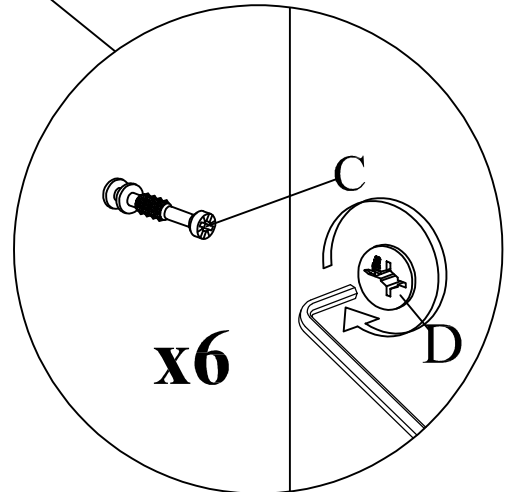
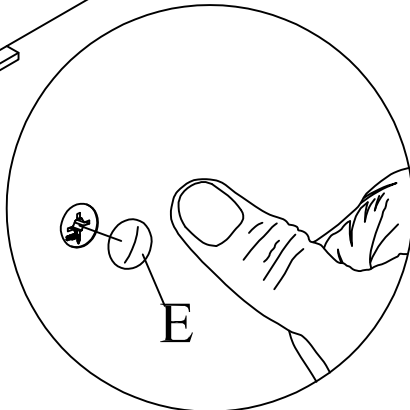

**Attach Minifix Cap as shown.*

Step 9

