

# ASSEMBLY INSTRUCTION

MODEL : CL - 3

Step 1 : Attach the sitter (C) to the back panel (A) .

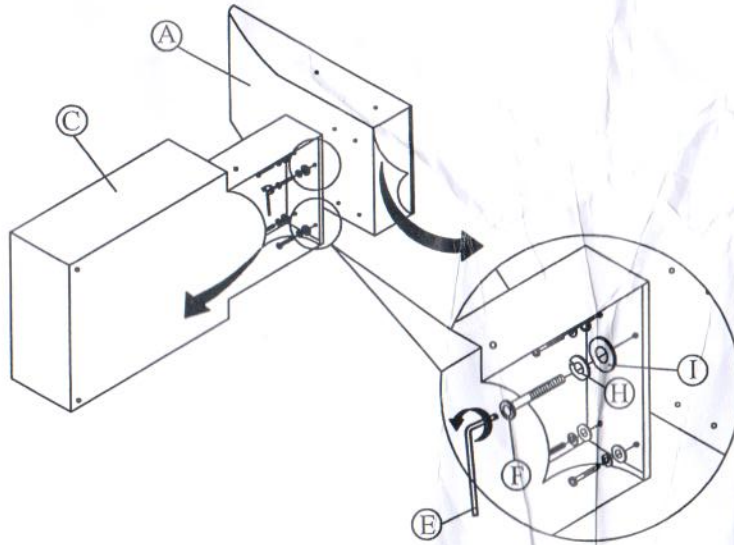

Step 2 : Attach the side wing (B) to the sitter (C) and back panel (A) .

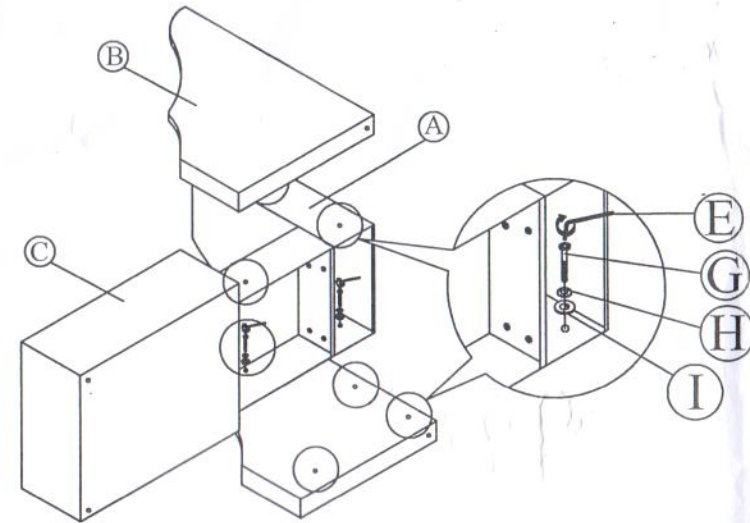



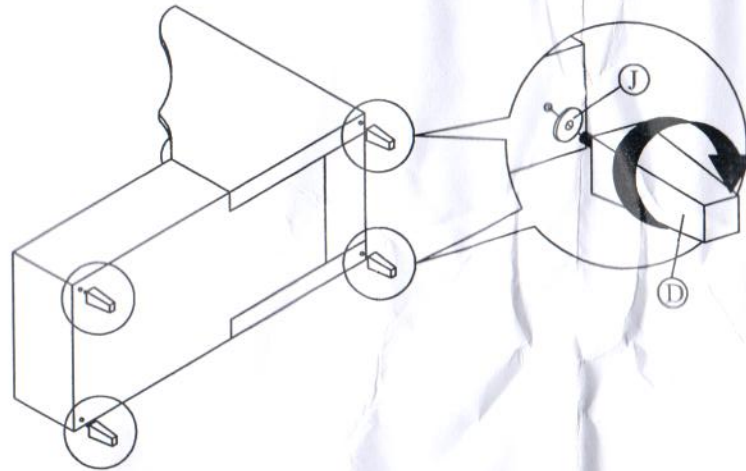







Step 3 : Install the legs (D) to sitter (C) and side wing (B).



Step 4 : Assembly complete.



A		1 pc
B		2 pcs
C		1 pc
D		4 pcs
E	 M4 x 65 mm	1 pc
F	 JCBC M6 X 40	4 pcs
G	 JCBC M6 X 50	6 pcs
H	 Spring Washers	10 pcs
I	 Flat Washers	10 pcs
J	 NO 35 Washers	4 pcs