

ASSEMBLY INSTRUCTION

MODEL : CF 9382-A (46")

A	Back Panel	1 pc
B	Arm B1 B2	2 pcs
C	Side Rail Back Panel	1 pc
D	Side Rail Front Panel	1 pc
E	130mm Ultra-Slat 137pc	1 pc
F	100mm Below-Slat 137pc	1 pc
G	Trundle Front Panel	1 pc
H	Trundle Side	2 pcs
I	Trundle Back Panel	1 pc
J	Wooden Block	4 pcs
K	Middle Panel	1 pc
Packing Hardware		
1	M5 x 70mm	1 pc
2	M4 x 65mm	1 pc
3	ICBB M8 X 20	20 pcs
4	CSK M4 x 32mm	64 pcs
5	ICRC M6 X 60	4 pcs
6	Roller	6 pcs
7	Spring Washers	4 pcs
8	M6 Flat Washers	4 pcs
9	CSK M3.5 x 16mm	24 pcs

Step 1 : Attach side rail (C) & (D) and Middle Panel (K) to arm (B) by pushing the bracket down to fit it.

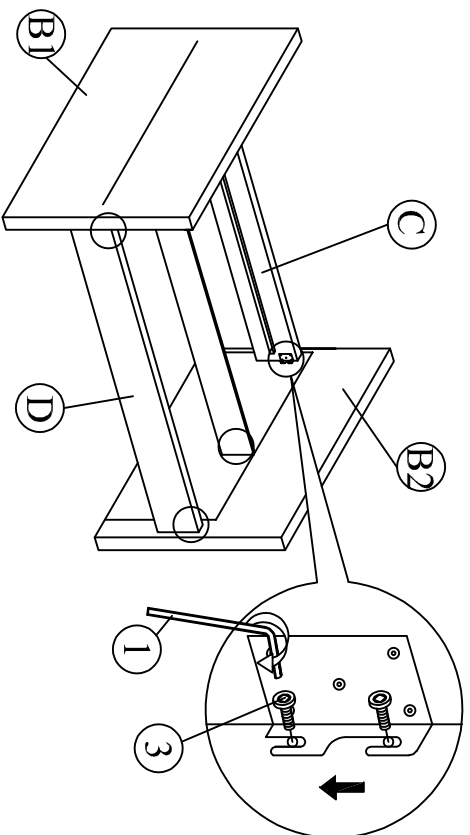

Step 2 : Attach the Back Panel (A) to the arm (B) as shown.

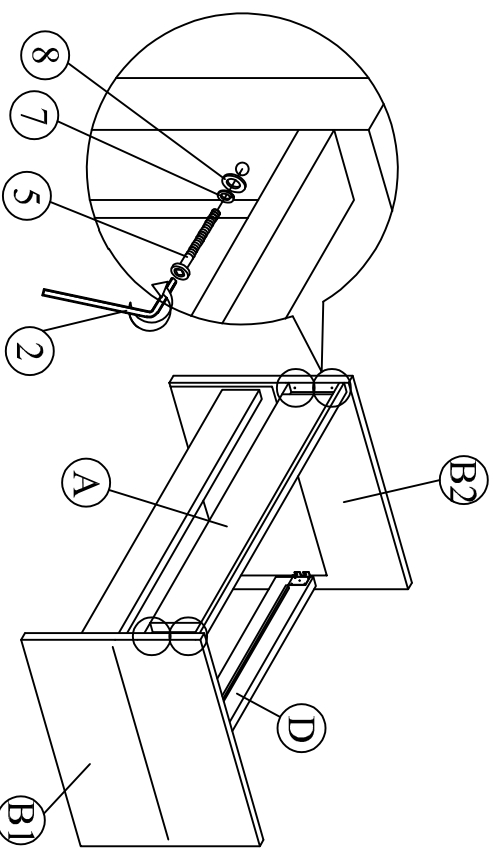

Step 3 : Tighten the 4 Corner with Allen Key (1). Install the slats to side rail. Tighten the slats (E) with CSK screw (4). The distance of the slats should be sufficient to obtain desirable bed stability.

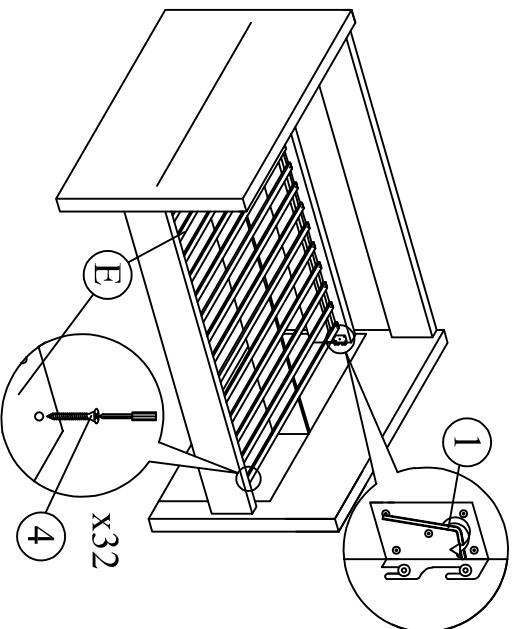

Step 4 : Attach trundle side panel (H) and trundle front panel (G) to trundle back panel (I) by pushing the bracket down to fit it.

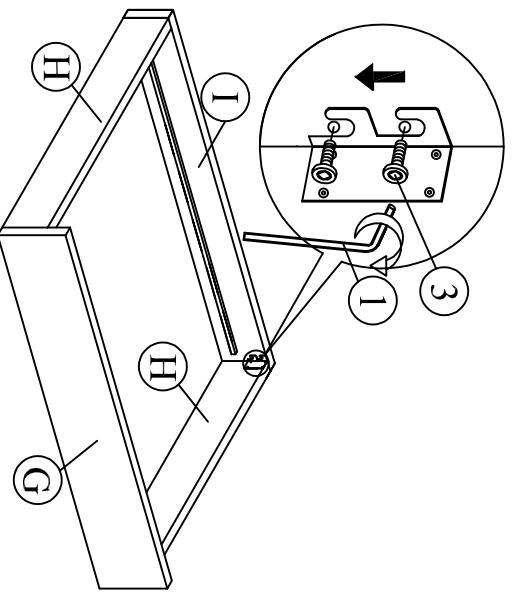

Step 5 : Affix the roller (6) to the slat (F) follow the marking on the slat (F).

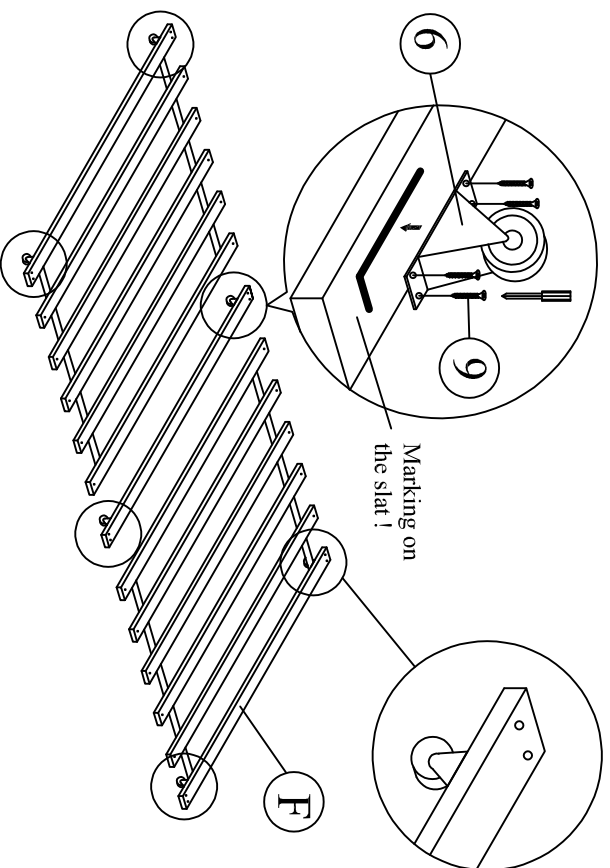

Step 6 : Tighten the 4 Corner with Allen Key (1) . Place the wooden blocks (J) at the corner of the trundle and fix the slat (F) to the trundle at (G) & (I).

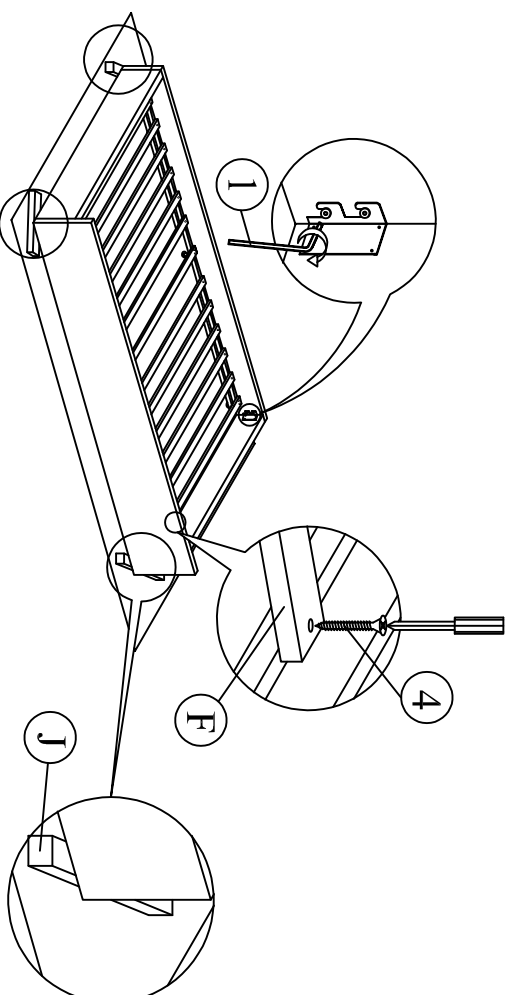

Step 7 : Assembly is complete.

