

MODEL : CF 9172 (4'6")

# ASSEMBLY INSTRUCTION

A	Arm A1	A2	2 pcs
B	Slat 13 Pcs		1 pc
C	Back Panel		1 pc
D	Side Rail		1 pc
E	Trundle Front Panel (FU)		1 pc
F	Trundle Back Panel		1 pc
G	Trundle Side Panel		2 pcs
H	Slat 13 Pcs		1 pc
I	Wooden Block		4 pcs
J	Middle Panel		1 pc
Packing Hardware			
1	M5 x 70 mm		1 pc
2	M4 x 65 mm		1 pc
3	CSK M4 x 32mm		64 pcs
4	CSK M4 x 16 mm		24 pcs
5	JCBRC M6 X 50		4 pcs
6	Flat Washer		4 pcs
7	Roller		6 pcs
8	JCBB M8 X 20		16 pcs

Step 1 : Attach side rail (D), Middle Panel (J) to arm (A) by pushing the bracket down to fit it. Tighten with Allen Key (1).

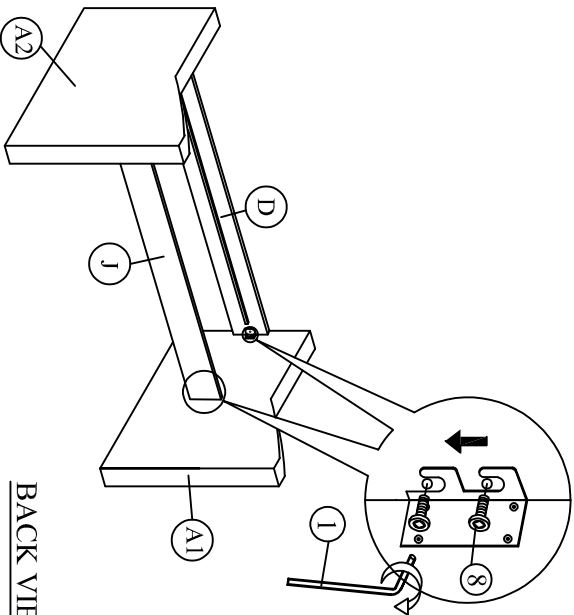

BACK VIEW

Step 2 : Attach the back panel (C) to arm (A). Tighten with Allen Key (2).

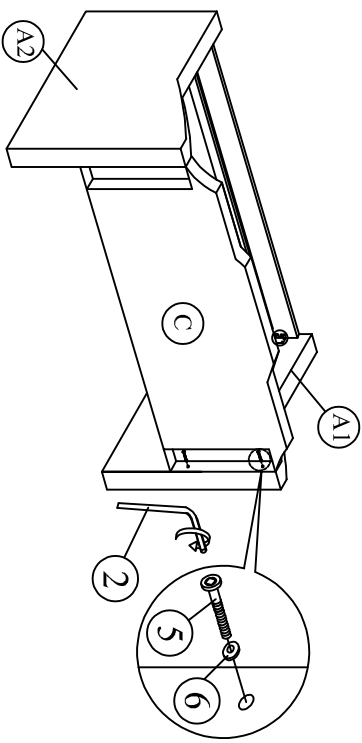

BACK VIEW

Step 3 : Tighten the slats with CSK screw (3). The distance of the slats should be sufficient to obtain desirable bed stability.

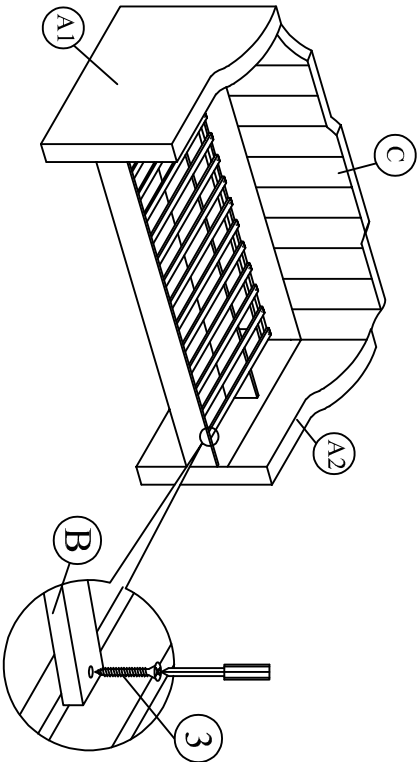

Step 4 : Attach trundle side panel (G) and trundle front panel (E) to trundle back panel (F) by pushing the bracket down to fit it.

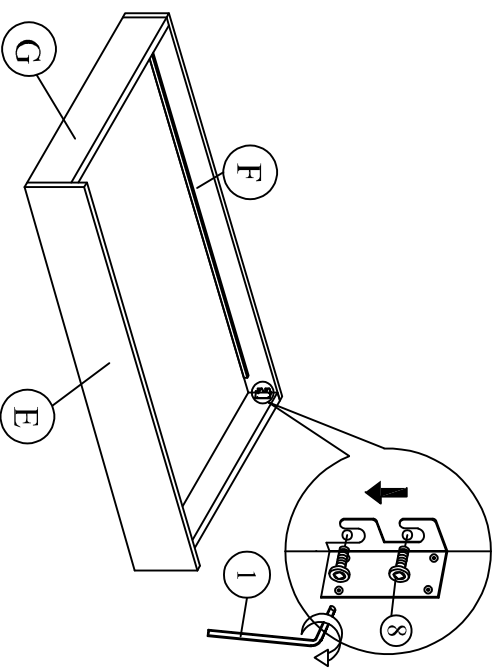

Step 5 : Affix the roller (7) to the slat (H) follow the marking on the slat (H).

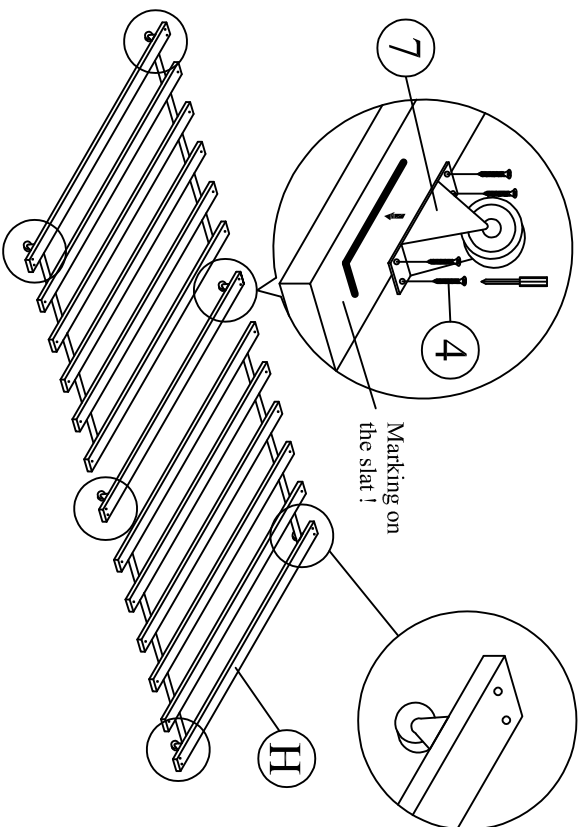

Step 6 : Place the wooden blocks (I) at the corner of the trundle and fix the slat (H) to the trundle at (F) & (G).

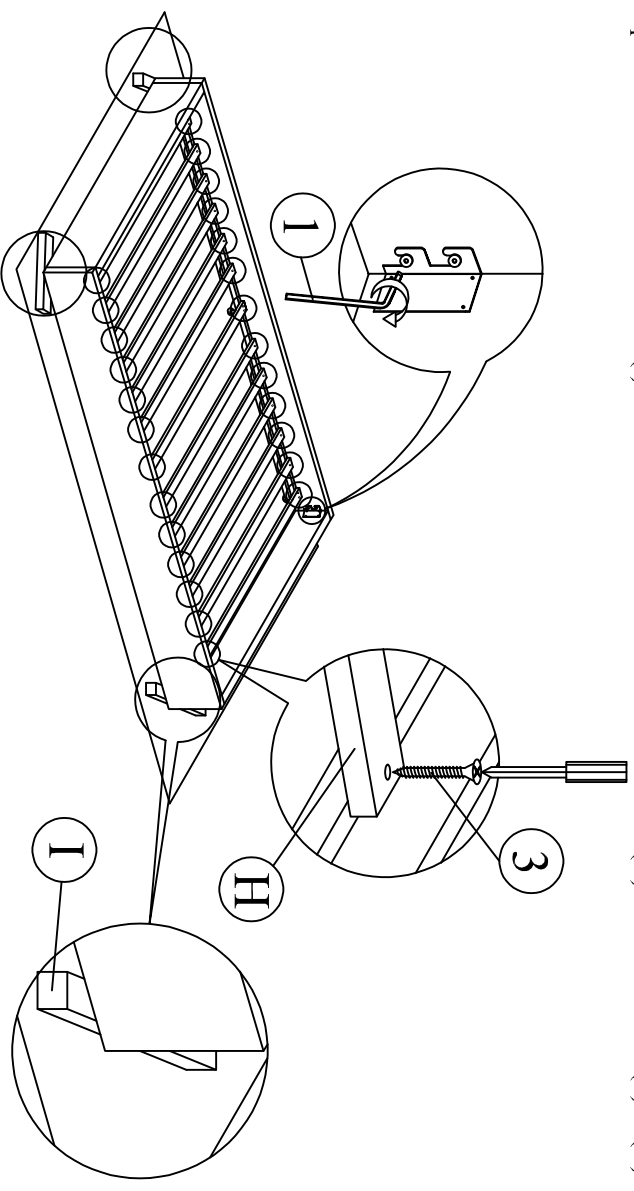

Step 7 : Assembly is complete.

