

ASSEMBLY INSTRUCTIONS

Read this instruction carefully. See hardware and furniture part list for guidance. Be sure all parts are complete, before you assemble. Place all wooden furniture parts on a clean and flat soft surface to prevent from being scratched. Follow the figure to start assembling.

CAUTIONS : 1. Do not FULLY - TIGHTEN the nut or nut bolt until all nut or bolt is ready assembled.
2. Do not OVER - TIGHTEN the nut or bolt to avoid causing damages to the thread.
3. Keep all hardware parts out of reach of children.

NOTE : THE LIST AND QUANTITY SHOWN ARE FOR 1 UNIT ASSEMBLY.

PART LIST		
ITEM	DESCRIPTION	QTY
A	TABLE TOP	1 PC
B	LEGS	4 PCS

PART LIST		
ITEM	DESCRIPTION	QTY
1	JCBC BOLT M6 x 60mm 	8 PCS
2	M6 FLAT WASHER 	8 PCS
3	M6 SPRING WASHER 	8 PCS
4	M4 ALLEN KEY 	1 PC

STEP 1

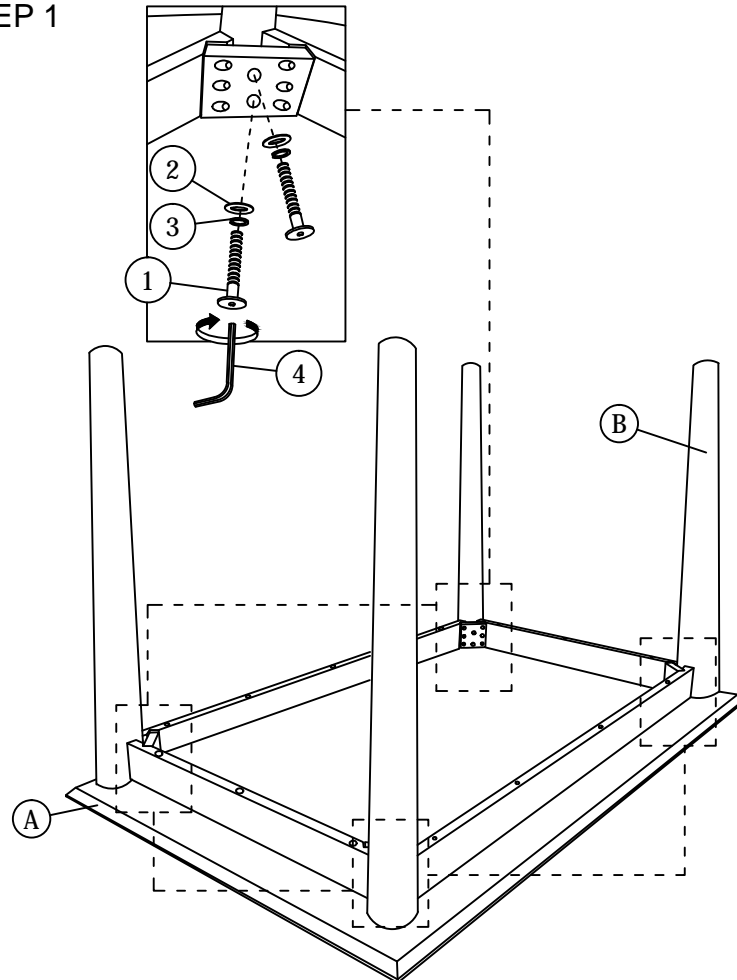

STEP 2

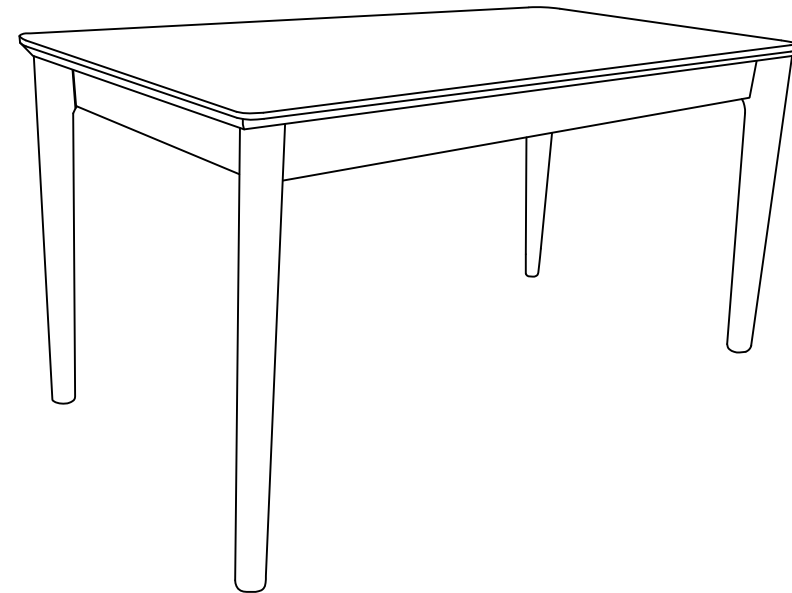

Read this instruction carefully. See hardware and furniture part list for guidance. Be sure all parts are complete, before you assemble. Place all wooden furniture parts on a clean and flat soft surface to prevent from being scratched. Follow the figure to start assembling.

CAUTIONS :

1. Do not FULLY - TIGHTEN the nut or nut bolt until all nut or bolt is ready assembled.
2. Do not OVER - TIGHTEN the nut or bolt to avoid causing damages to the thread.
3. Keep all hardware parts out of reach of children.

NOTE : THE LIST AND QUANTITY SHOWN ARE FOR 1 UNIT ASSEMBLY.

Tool needed : Screwdriver (not provider).

PART LIST		
ITEM	DESCRIPTION	QTY
A	LEG FRONT	2 PCS
B	LEG BACK (L/R)	2 PCS
C	CUSHION	1 PC

HARDWARE LIST		
ITEM	DESCRIPTION	QTY
1	JCBB BOLT M8 x 50mm 	8pcs
2	M8 FLAT WASHER 	8pcs
3	M8 SPRING WASHER 	8pcs
4	M5 ALLEN KEY (BALL SHAPE) 	1PC

STEP 1

Take out LEG FRONT (A) , LEG BACK (B) for the CUSHION BOTTOM (C).

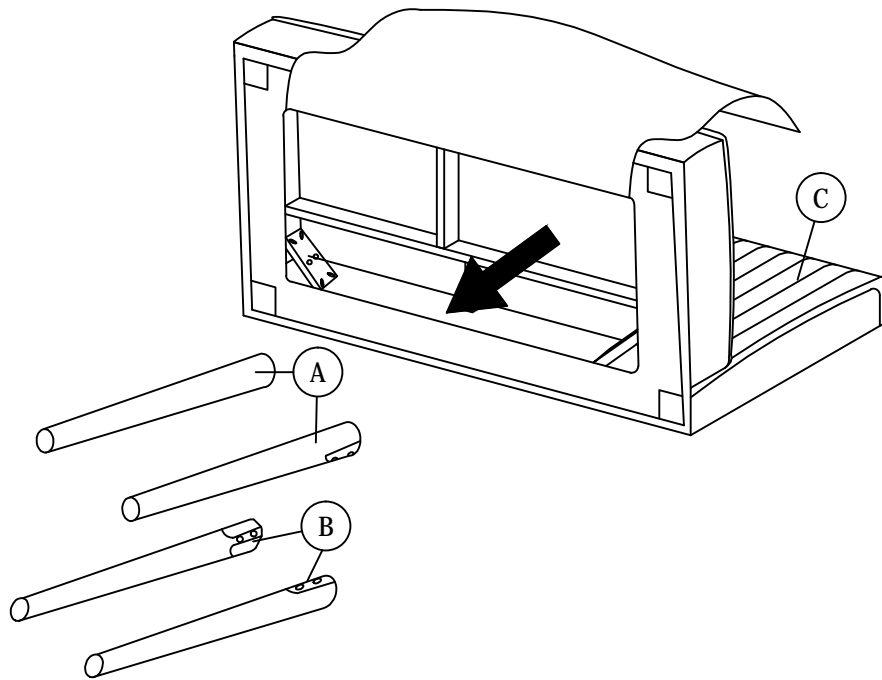

STEP 2

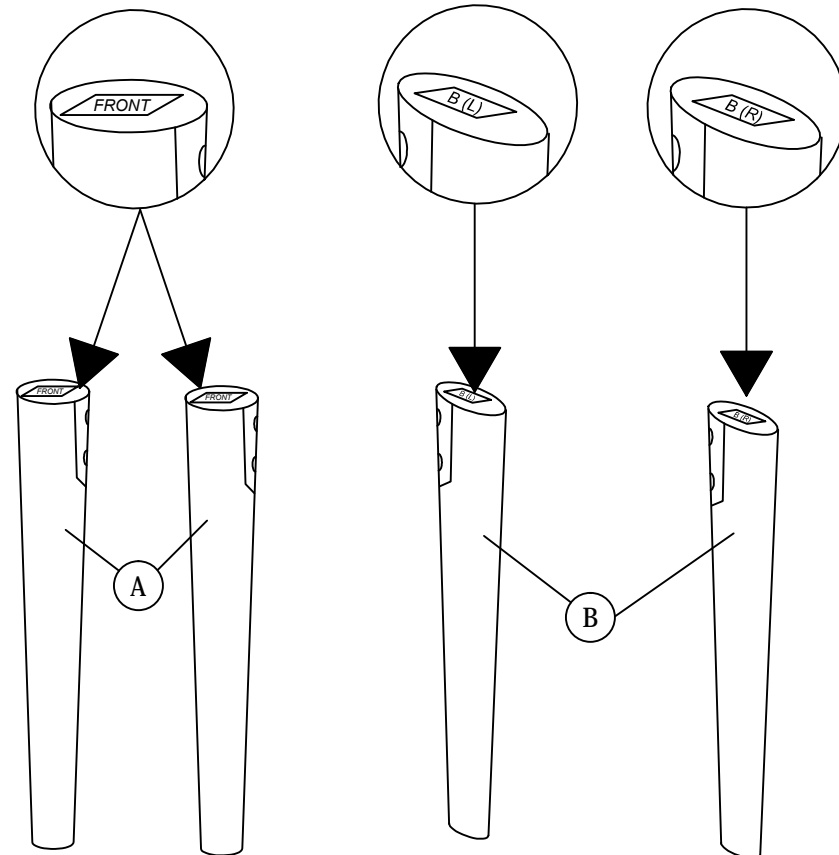

ASSEMBLY INSTRUCTIONS

STEP 3

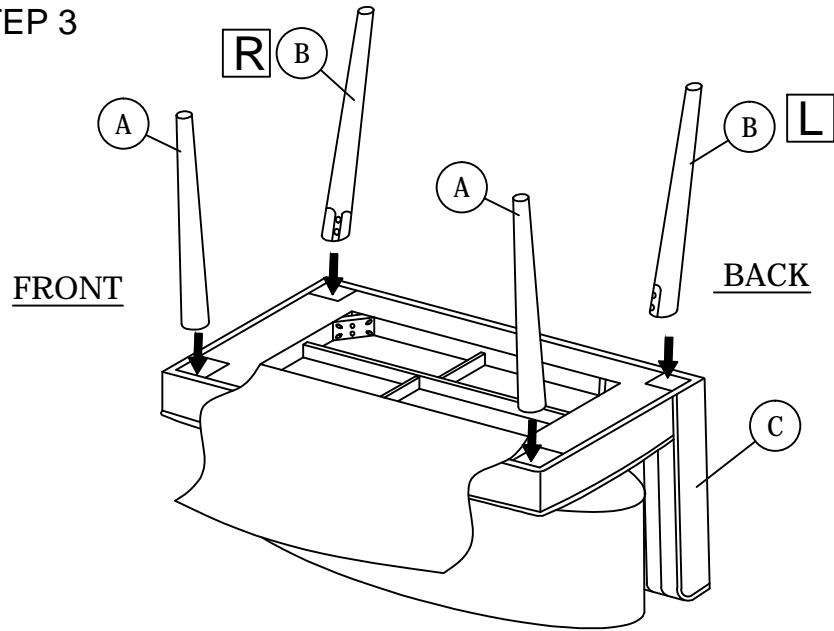

STEP 5

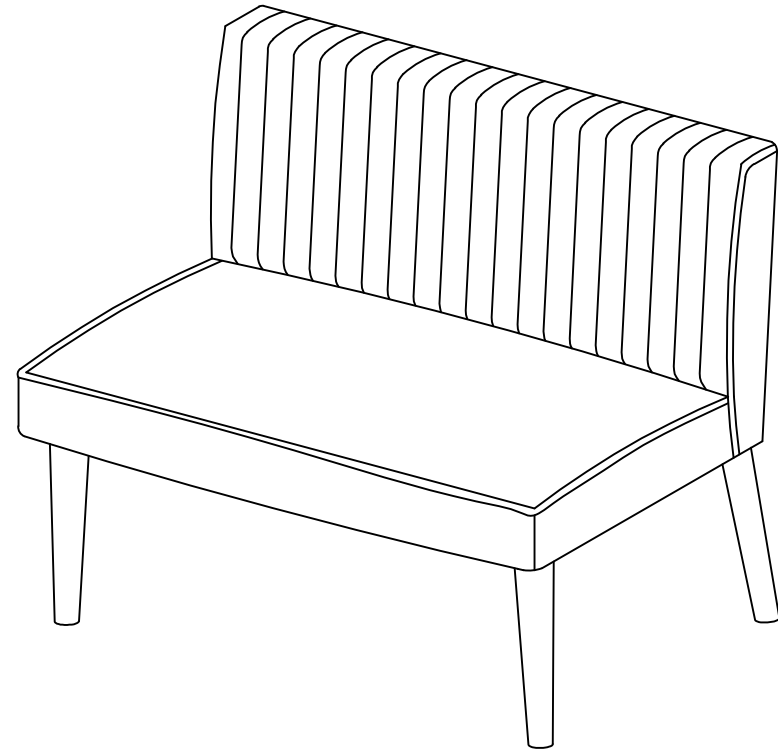

STEP 4

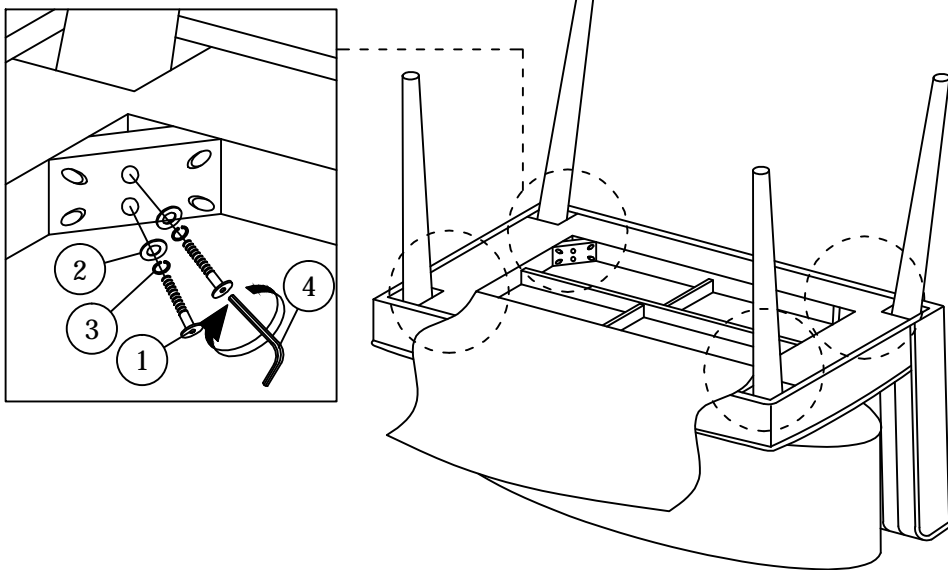

Read this instruction carefully. See hardware and furniture part list for guidance. Be sure all parts are complete, before you assemble. Place all wooden furniture parts on a clean and flat soft surface to prevent from being scratched. Follow the figure to start assembling.

CAUTIONS : 1. Do not FULLY - TIGHTEN the nut or nut bolt until all nut or bolt is ready assembled.
 2. Do not OVER - TIGHTEN the nut or bolt to avoid causing damages to the thread.
 3. Keep all hardware parts out of reach of children.

NOTE : THE LIST AND QUANTITY SHOWN ARE FOR 1 UNIT ASSEMBLY.

Tool needed : Screwdriver (not provider).

PART LIST		
ITEM	DESCRIPTION	QTY
A	LEG FRONT	2 PCS
B	LEG BACK (L/R)	2 PCS
C	CUSHION	1 PC

HARDWARE LIST		
ITEM	DESCRIPTION	QTY
1	JCBB BOLT M8 x 50mm 	8pcs
2	M8 FLAT WASHER 	8pcs
3	M8 SPRING WASHER 	8pcs
4	M5 ALLEN KEY (BALL SHAPE) 	1PC

STEP 1

Take out LEG FRONT (A) , LEG BACK (B) for the CUSHION BOTTOM (C).

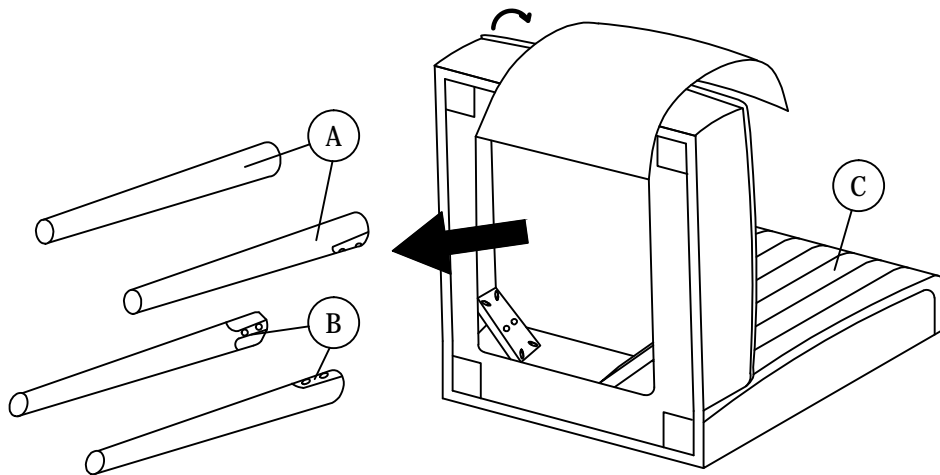

STEP 2

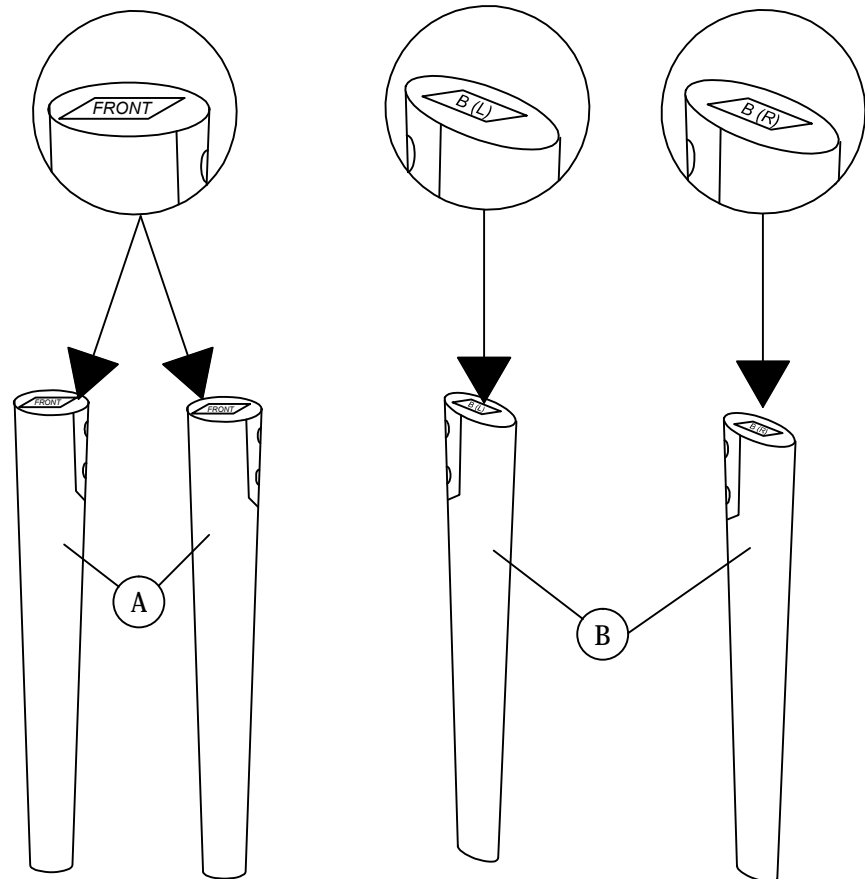

ASSEMBLY INSTRUCTIONS

STEP 3

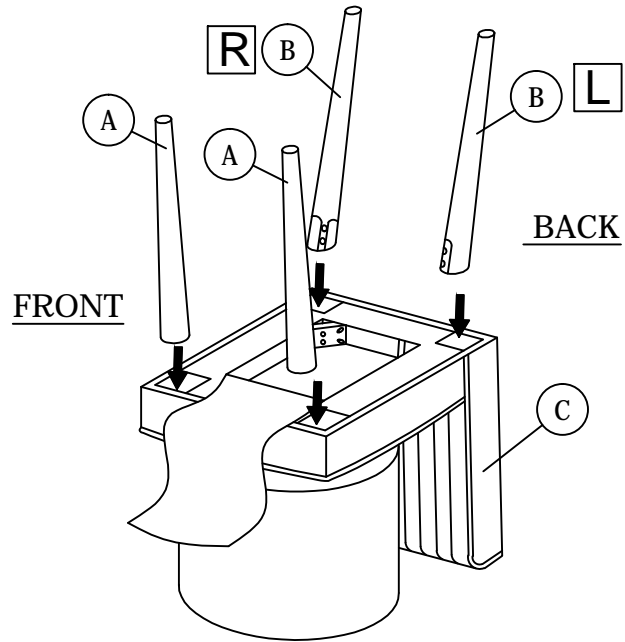

STEP 5

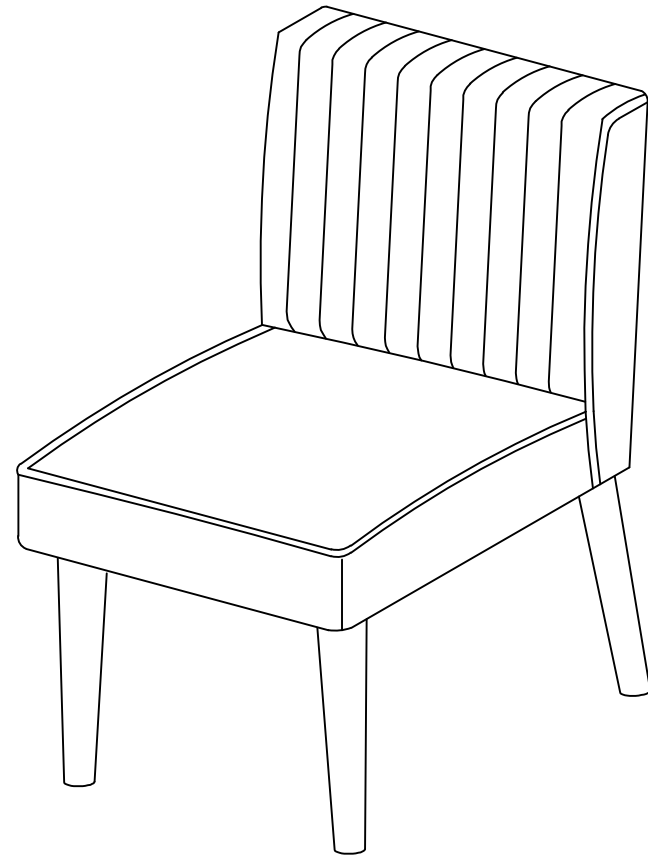

STEP 4

