

Read this instruction carefully. See hardware and furniture part list for guidance. Be sure all parts are complete, before you assemble. Place all wooden furniture parts on a clean and flat soft surface to prevent from being scratched. Follow the figure to start assembling.

PART LIST		
ITEM	DESCRIPTION	QTY
A	BENCH	1 PC
B	LEG	4 PCS

HARDWARE LIST		
ITEM	DESCRIPTION	QTY
1	JCBB Bolt M8 x 45mm 	8 PCS
2	M8 FLAT WASHER 	8 PCS
3	M8 SPRING WASHER 	8 PCS
4	M5 ALLEN KEY (BALL SHAPE) 	1 PC

CAUTIONS : 1. Do not FULLY - TIGHTEN the nut or nut bolt until all nut or bolt is ready assembled.
 2. Do not OVER - TIGHTEN the nut or bolt to avoid causing damages to the thread.
 3. Keep all hardware parts out of reach of children.

NOTE : THE LIST AND QUANTITY SHOWN ARE FOR 1 UNIT ASSEMBLY.

STEP 1

1.1 Open the zip at the bottom of cushion seat and take out leg.

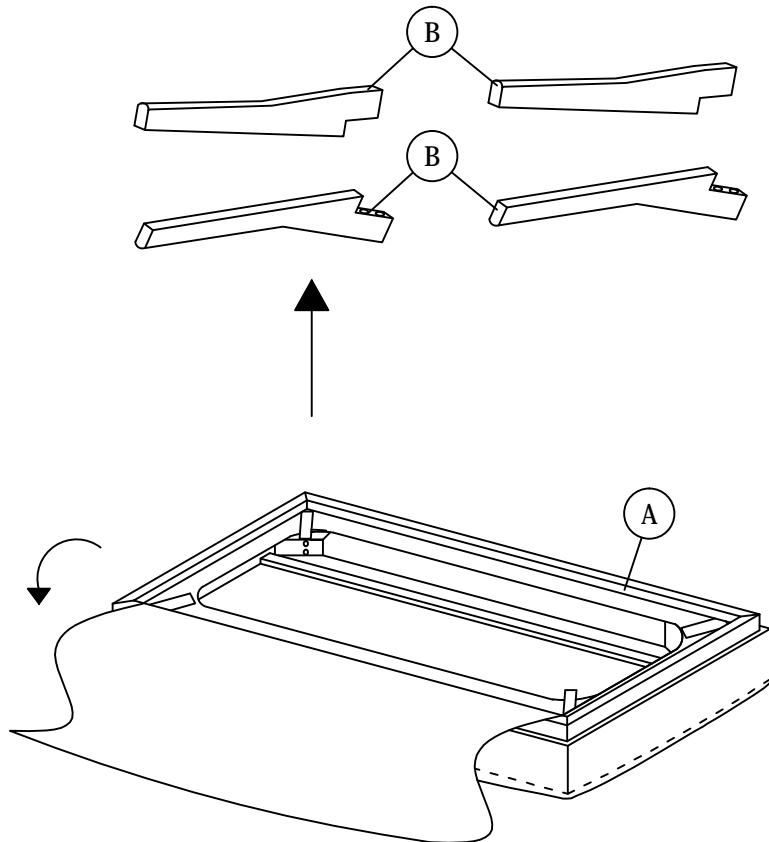

STEP 2

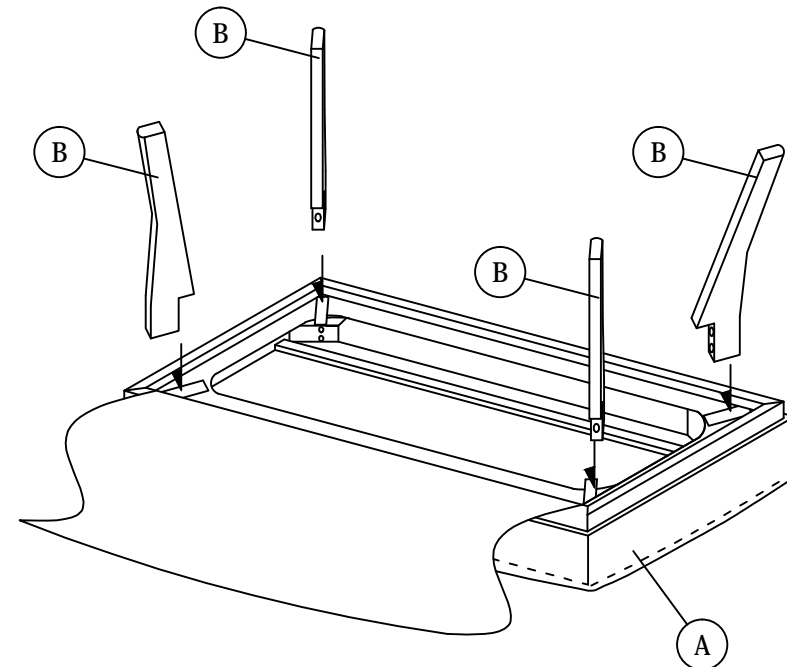

ASSEMBLY INSTRUCTIONS

STEP 3

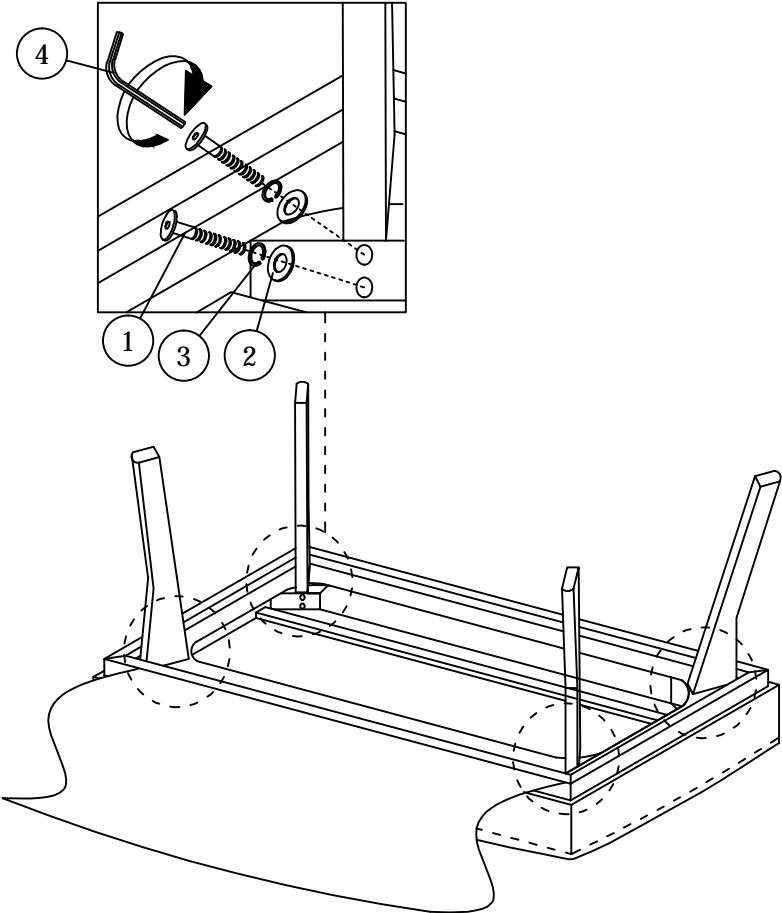

STEP 4

