

Read this instruction carefully. See hardware and furniture part list for guidance. Be sure all parts are complete, before you assemble. Place all wooden furniture parts on a clean and flat soft surface to prevent from being scratched. Follow the figure to start assembling.

CAUTIONS : 1. Do not FULLY - TIGHTEN the nut or nut bolt until all nut or bolt is ready assembled.
 2. Do not OVER - TIGHTEN the nut or bolt to avoid causing damages to the thread.
 3. Keep all hardware parts out of reach of children.

NOTE : THE LIST AND QUANTITY SHOWN ARE FOR 1 UNIT ASSEMBLY.
 Tool needed : Screwdriver & Hammer (not provider).

PART LIST		
ITEM	DESCRIPTION	QTY
A	HEADBOARD	1 PC
B	FOOTBOARD	1 PC
C	SIDE RAIL (L&R)	2 PCS
D	CENTER RAIL	1 PC
E	CENTER SUPPORT LEG	3 PCS
F	LEG	4 PCS
G	BED SLAT	1 SET
H	SIDE RAIL SUPPORT	2 PCS

HARDWARE LIST		
ITEM	DESCRIPTION	QTY
1	JCBC BOLT M6 x 20mm	2 PCS
2	JCBC BOLT M6 x 30mm	2 PCS
3	JCBC BOLT M6 x 45mm	8 PCS
4	JCBB BOLT M8 x 40mm	4 PCS
5	JCBB BOLT M8 x 50mm	12 PCS
6	M6 SPRING WASHER	4 PCS
7	M6 FLAT WASHER	4 PCS
8	M8 SPRING WASHER	16 PCS
9	M8 FLAT WASHER	16 PCS
10	WOOD SCREW M4 x 25mm	8 PCS
11	WOOD SCREW M4 x 38mm	9 PCS
12	WOOD DOWEL M10 x 30mm	8 PCS
13	M4 ALLEN KEY (BALL SHAPE)	1 PC
14	M5 ALLEN KEY (BALL SHAPE)	1 PC
15	VMB 3062 L Bracket	2 PCS

STEP 1

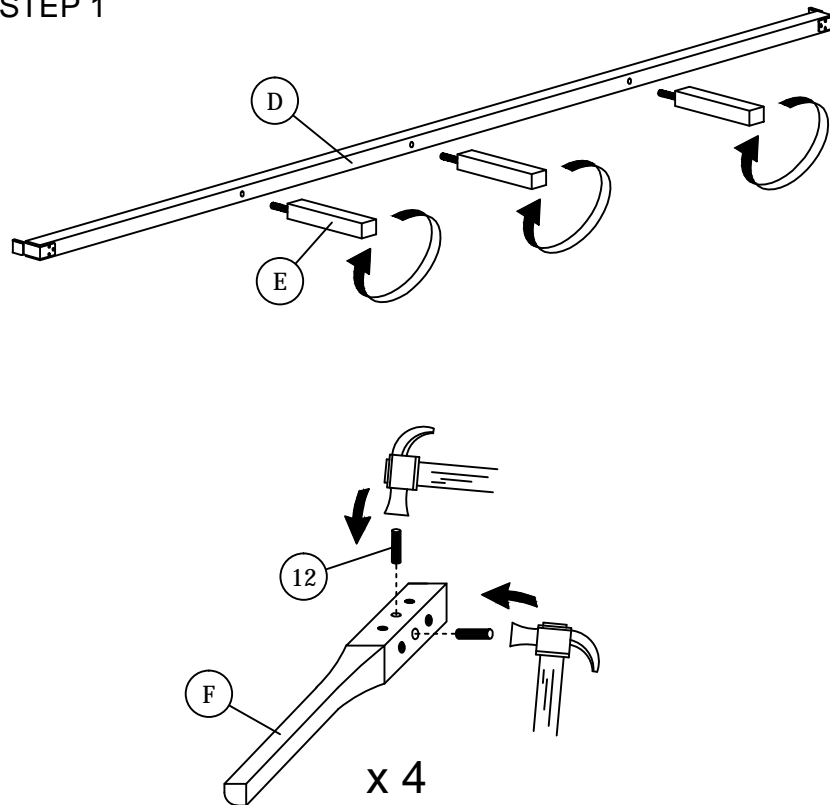

STEP 2

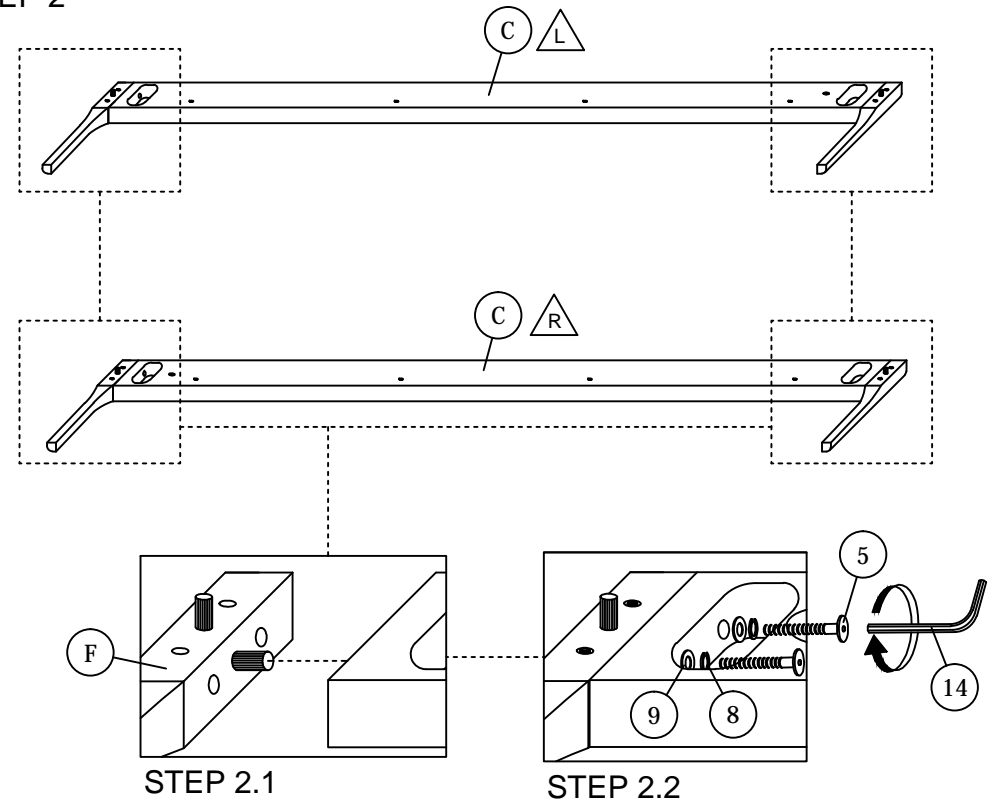

ASSEMBLY INSTRUCTIONS

STEP 3

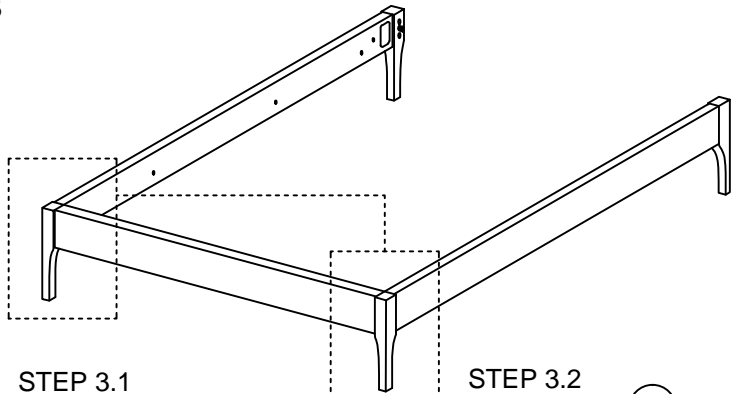

STEP 3.1

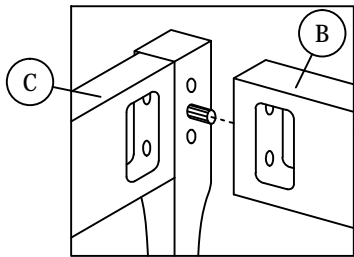

STEP 3.2

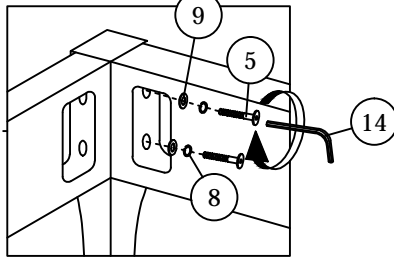

STEP 4

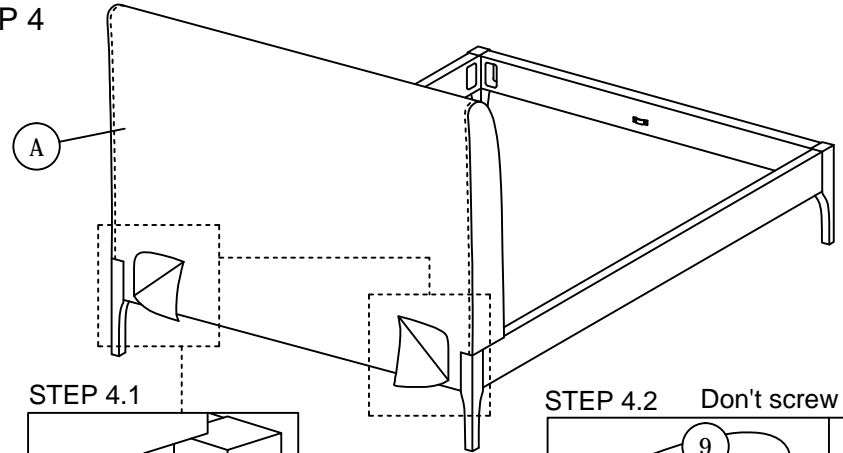

STEP 4.1

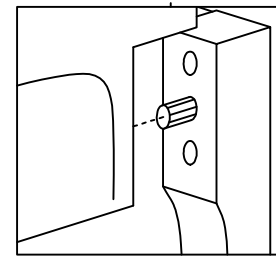

STEP 4.2 Don't screw tied

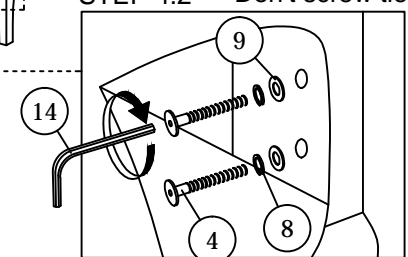

STEP 5

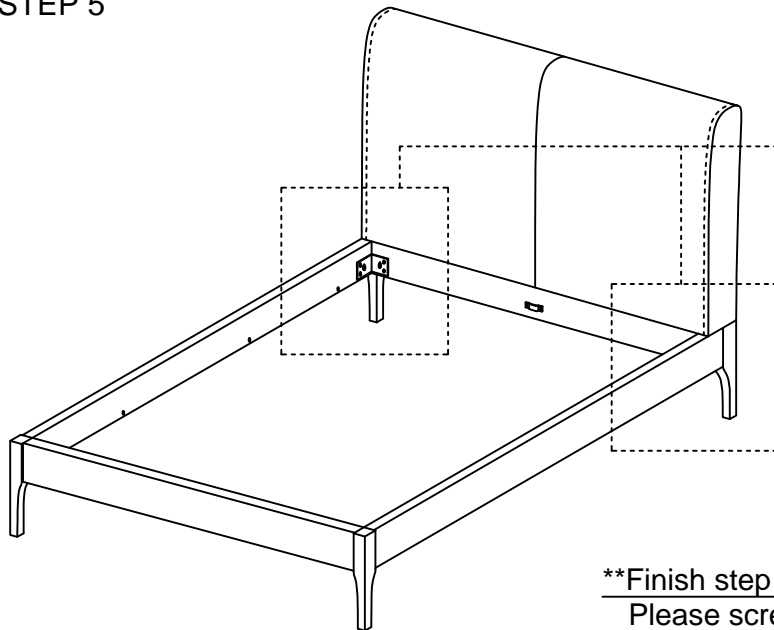

STEP 5.1

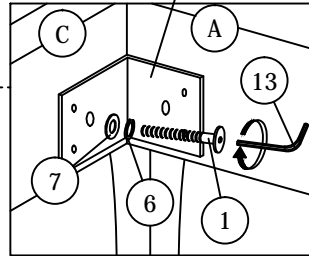

STEP 5.2

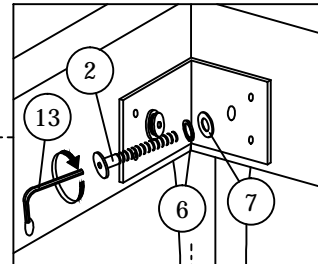

STEP 5.3

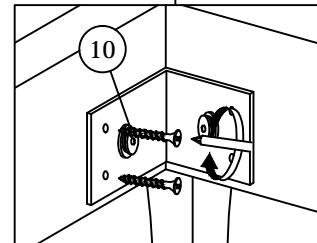

STEP 5.4

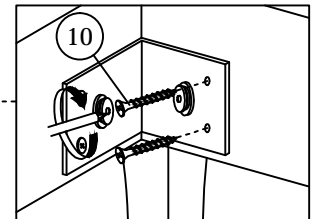

****Finish step 5,
Please screw tied the step 4 bolt.**

ASSEMBLY INSTRUCTIONS

STEP 6

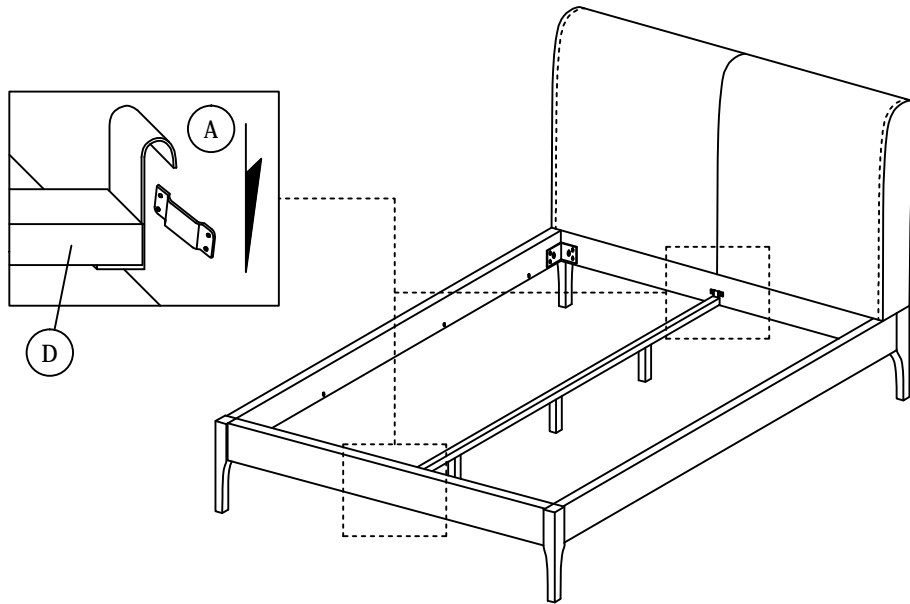

STEP 7

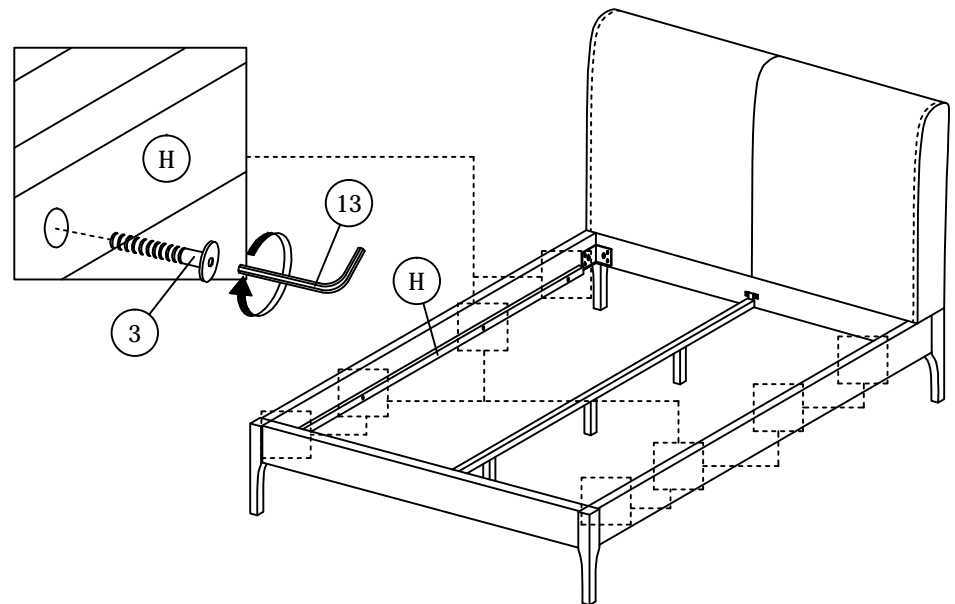

STEP 8

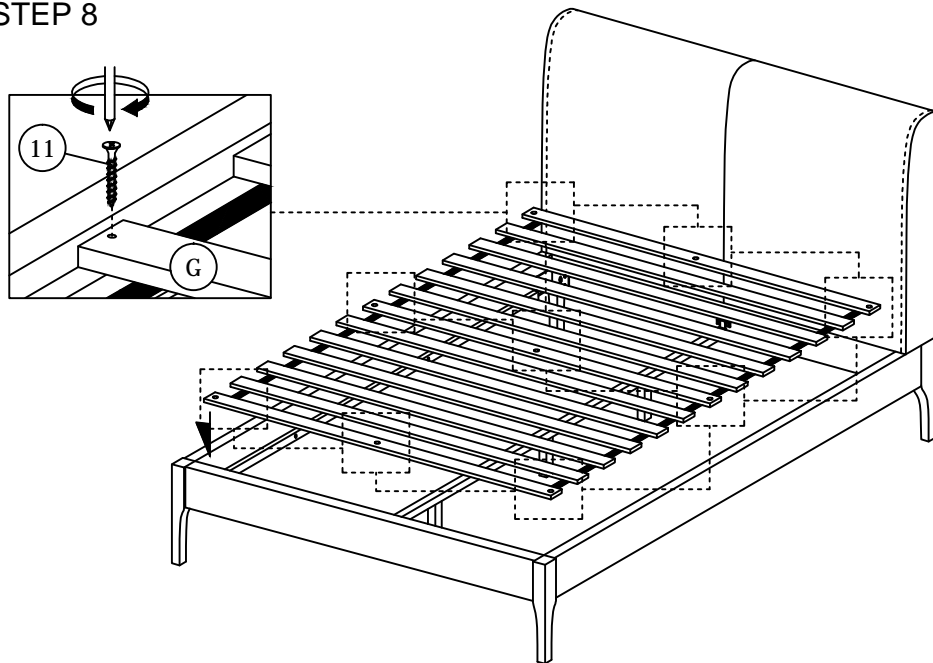

STEP 9

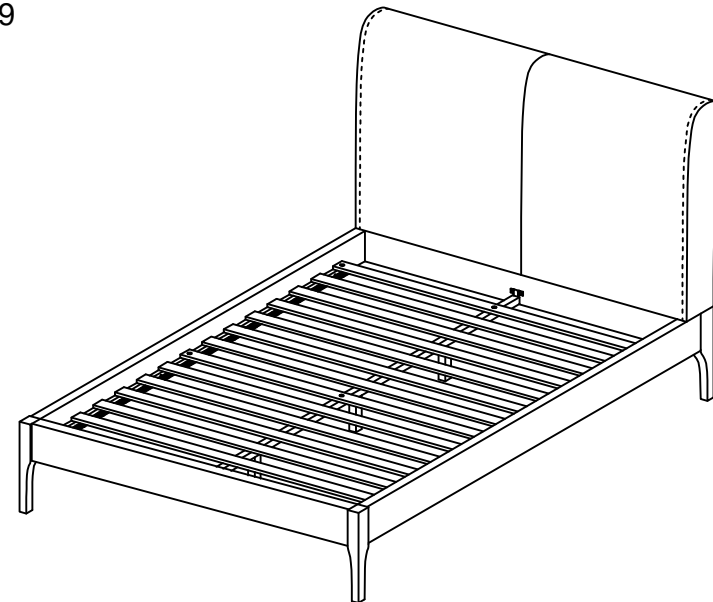

* When moving the bed position, the center support legs must be adjust to be straight to avoid any broken problem.