

Read this instruction carefully. See hardware and furniture part list for guidance. Be sure all parts are complete, before you assemble. Place all wooden furniture parts on a clean and flat soft surface to prevent from being scratched. Follow the figure to start assembling.

**CAUTIONS :** 1. Do not FULLY - TIGHTEN the nut or nut bolt until all nut or bolt is ready assembled.  
 2. Do not OVER - TIGHTEN the nut or bolt to avoid causing damages to the thread.  
 3. Keep all hardware parts out of reach of children.

**NOTE :** THE LIST AND QUANTITY SHOWN ARE FOR 1 UNIT ASSEMBLY.

Tool needed : Screwdriver & Rubber Mallet (not provider).

PART LIST			
ITEM	DESCRIPTION	BOX	QTY
A	HEADBOARD	1	1 PC
B	HEADBOARD LEG	2	2 PCS
C	FOOTBOARD	1	1 PC
D	SIDE RAIL	2	2 PCS
E	CENTER RAIL	2	1 PC
F	CENTER SUPPORT LEG	2	3 PCS
G	BED SLAT	3	1 SET

HARDWARE LIST (BOX : 2)			
ITEM	DESCRIPTION		QTY
1	JCBC BOLT M6 x 40mm		1 PC
2	JCBC BOLT M6 x 60mm		8 PCS
3	M6 BEND WASHER 3013 (RB)		8 PCS
4	WOOD SCREW M4 x 32mm		8 PCS
5	WOOD DOWEL M8 x 30mm		4 PCS
6	M4 ALLEN KEY (BALL SHAPE)		1 PC

## STEP 1

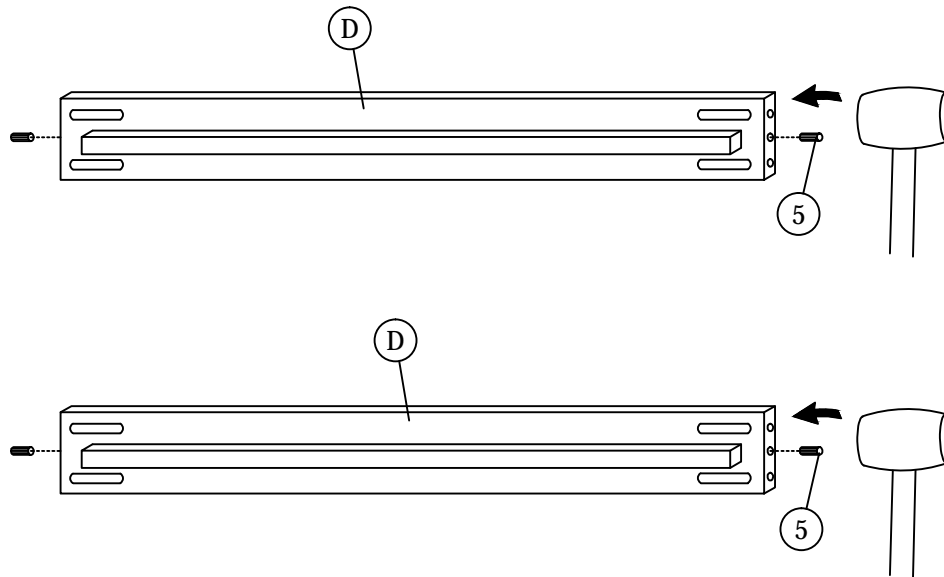

## STEP 2

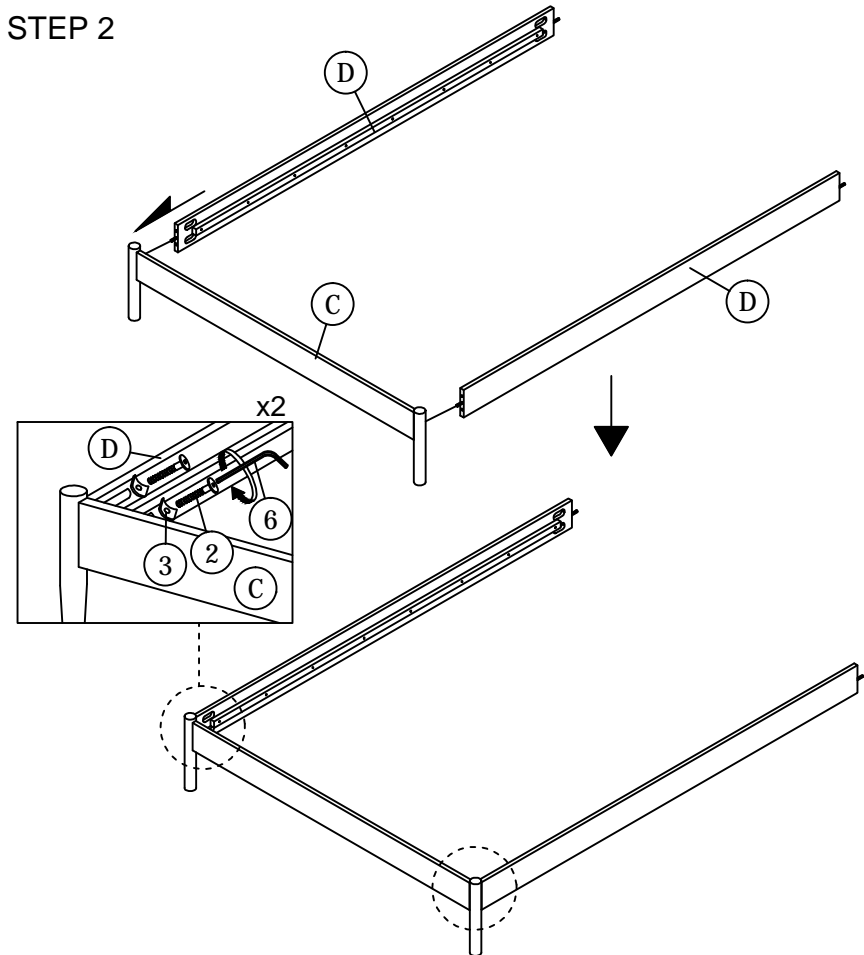

# ASSEMBLY INSTRUCTIONS

## STEP 3

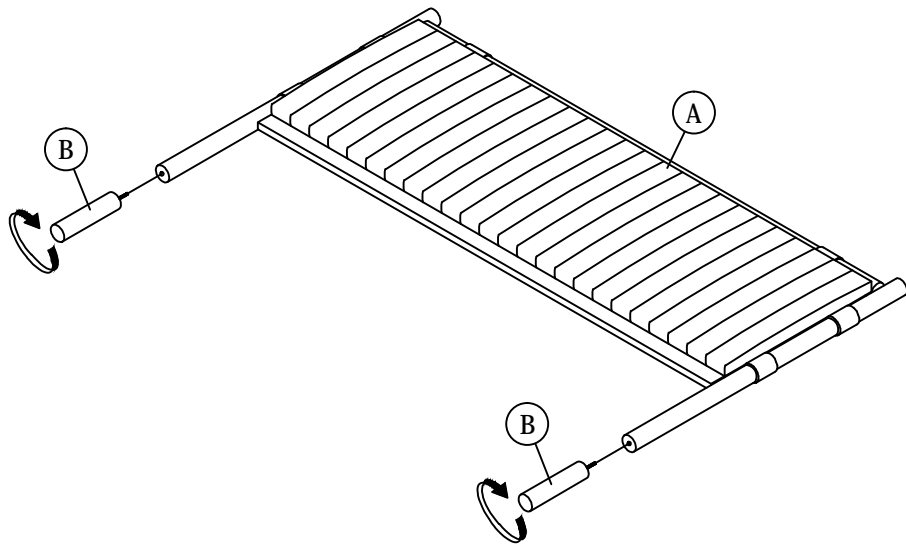

## STEP 4

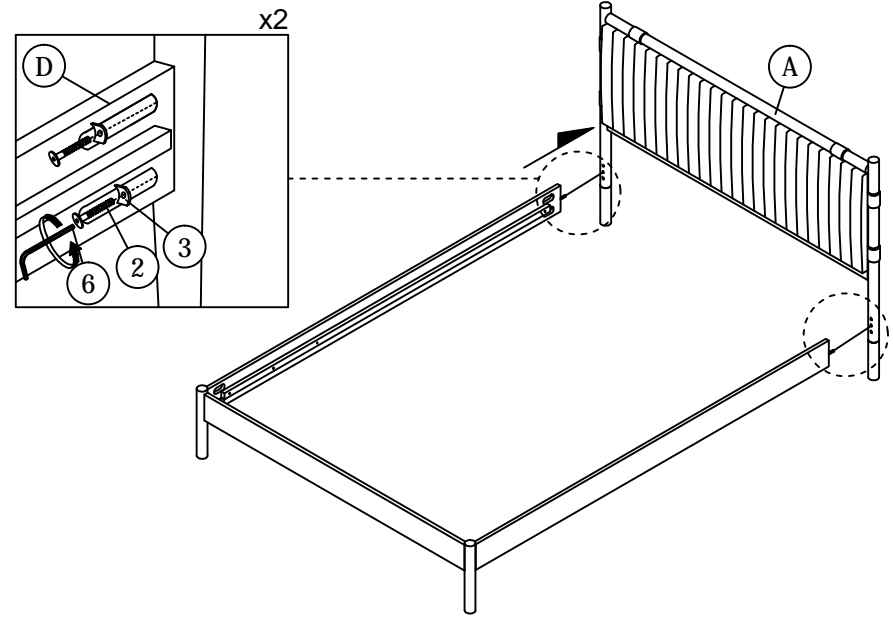

## STEP 5

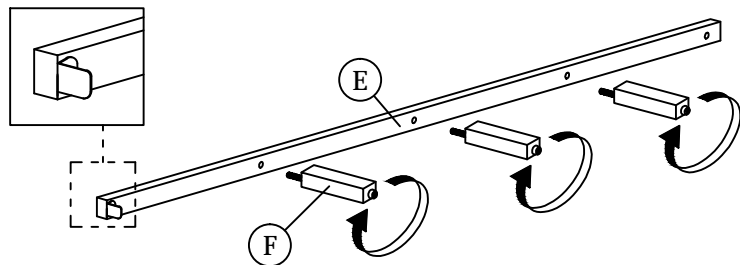

## STEP 6

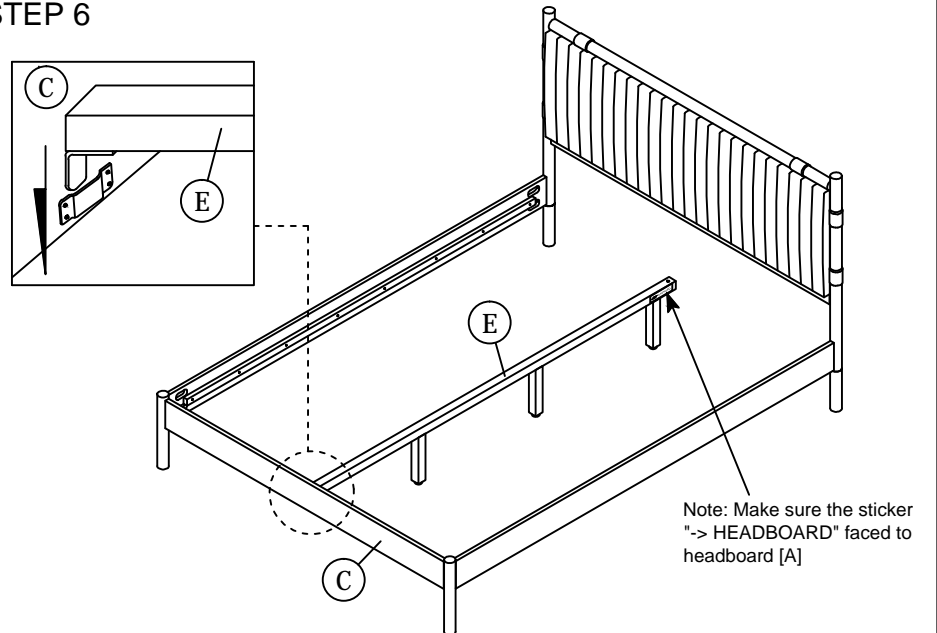

# ASSEMBLY INSTRUCTIONS

## STEP 7

### STEP 7.1

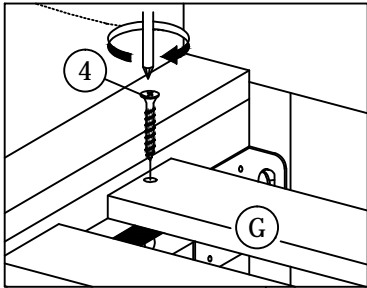

### STEP 7.2

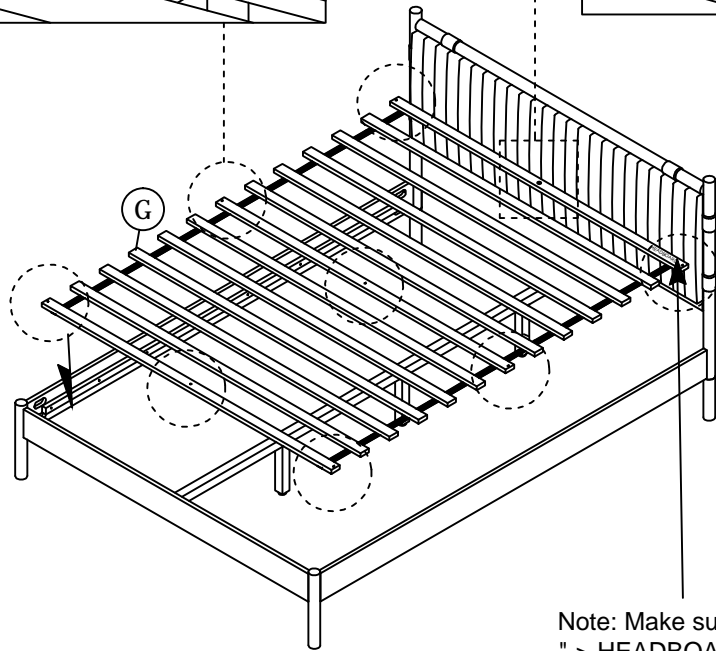
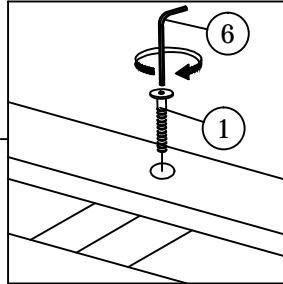

Note: Make sure the sticker  
"-> HEADBOARD" faced to  
headboard [A]

## STEP 8

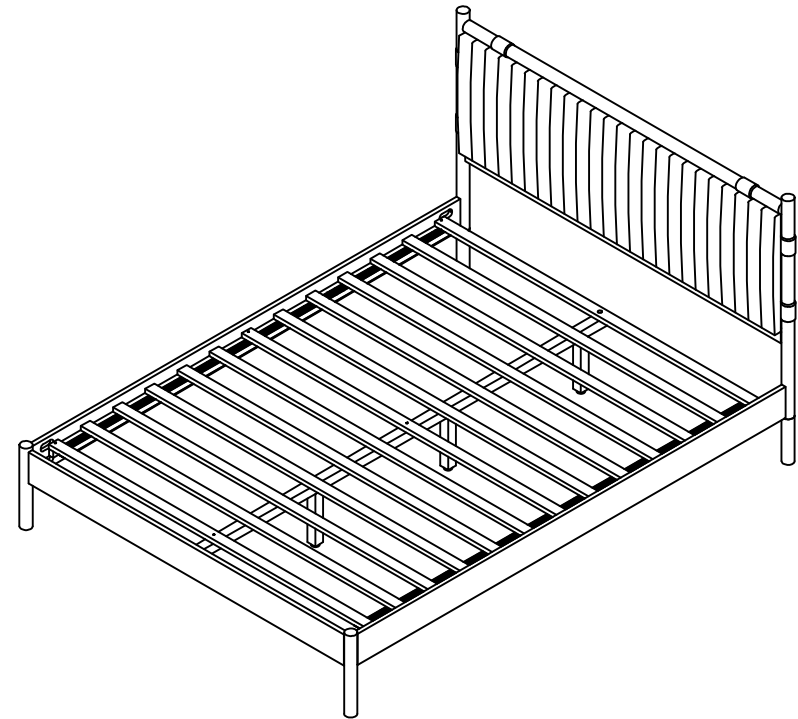

\* When moving the bed position, the center support legs  
must be adjust to be straight to avoid any broken problem.