













Read this instruction carefully. See hardware and furniture part list for guidance.
 Be sure all parts are complete, before you assemble. Place all wooden furniture parts on a clean and flat soft surface to prevent from being scratched.
 Follow the figure to start assembling.

CAUTION : 1. Do not FULLY - TIGHTEN the nuts or nuts bolts until they are ready for assembly.
 2. Do not OVER - TIGHTEN the nuts or bolts to avoid causing damages to the thread.
 3. Keep all hardware parts out of reach of children.

NOTE : THE LIST AND QUANTITY SHOWN ARE FOR 1 UNIT ASSEMBLY.

Tools needed : Screwdriver (not provided).

PART LIST			
ITEM	DESCRIPTION	BOX	QTY
A	HEADBOARD	1	1 PC
B	FOOTBOARD	2	1 PC
C	BED LEG	2	4 PCS
D	SIDE RAIL	2	2 PCS
E	CENTER RAIL	2	1 PC
F	CENTER SUPPORT LEG	2	3 PCS
G	BED SLAT	3	1 SET

HARDWARE LIST (BOX : 2)		
ITEM	DESCRIPTION	QTY
1	JCBC BOLT M6 x 30mm 	2 PCS
2	JCBC BOLT M6 x 20mm 	6 PCS
3	M6 SPRING WASHER 	8 PCS
4	M6 FLAT WASHER 	8 PCS
5	M8 SPRING WASHER 	4 PCS
6	WOOD SCREW M4 x 20mm 	16 PCS
7	WOOD SCREW M4 x 38mm 	9 PCS
8	5/16" HEX NUT 	4 PCS
9	VMB 3087 (BLACK) 	4 PCS
10	SPANNER (13mm) 	1 PC
11	M4 ALLEN KEY (BALL SHAPE) 	1 PC
12	M5 ALLEN KEY (BALL SHAPE) 	1 PC

STEP 1

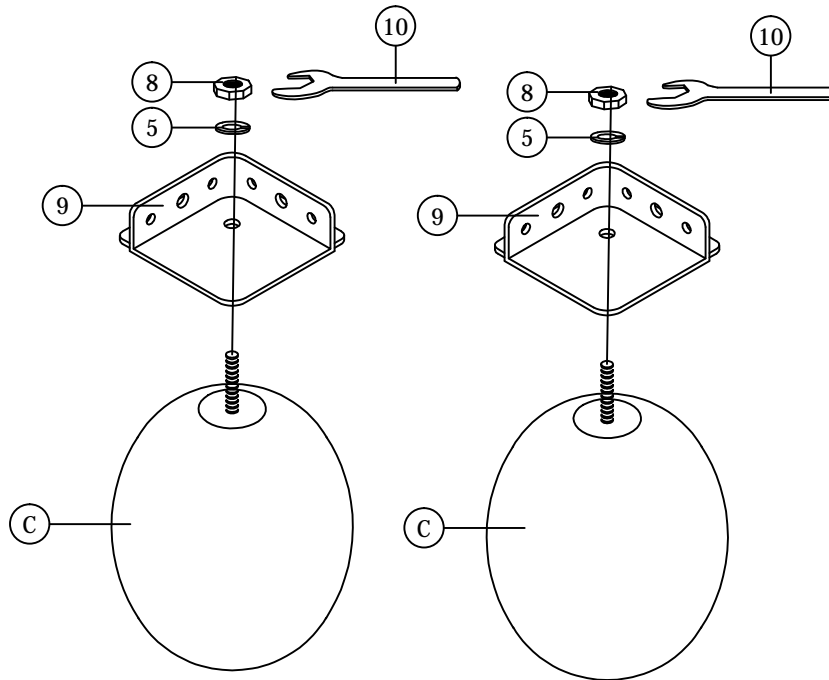

STEP 2

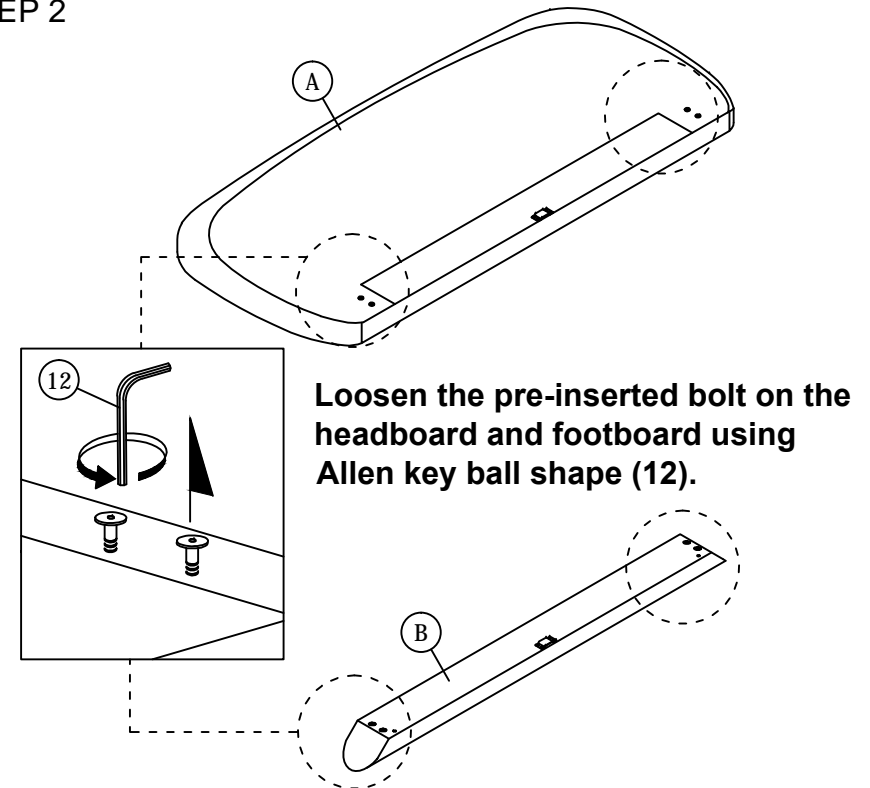

ASSEMBLY INSTRUCTIONS

STEP 3

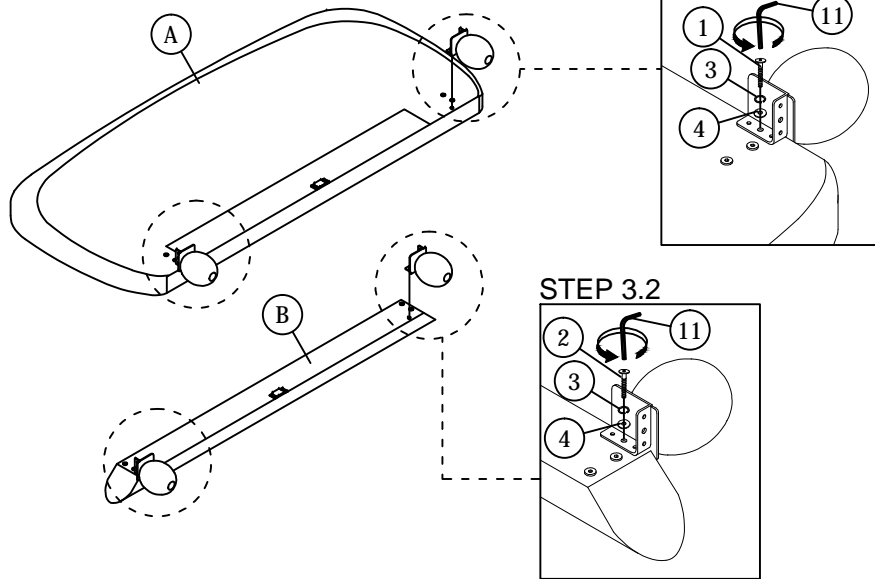

STEP 4

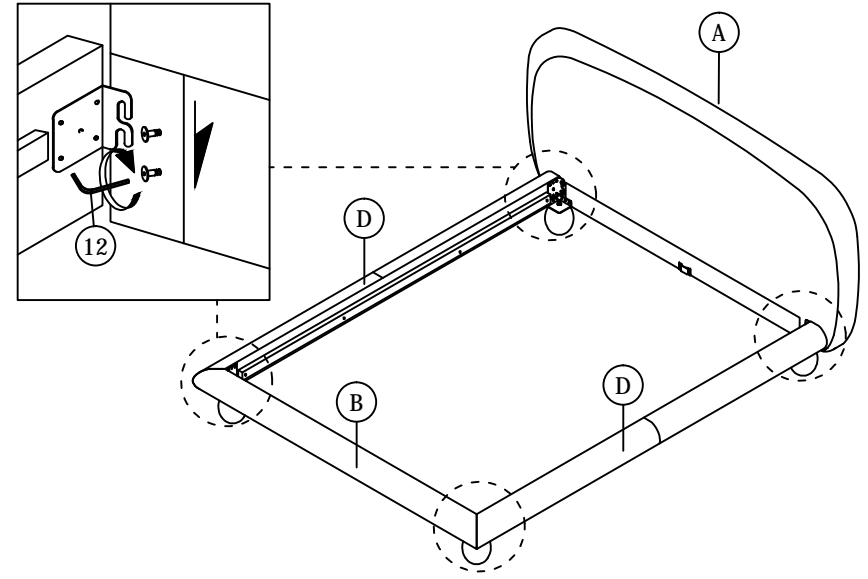

STEP 5

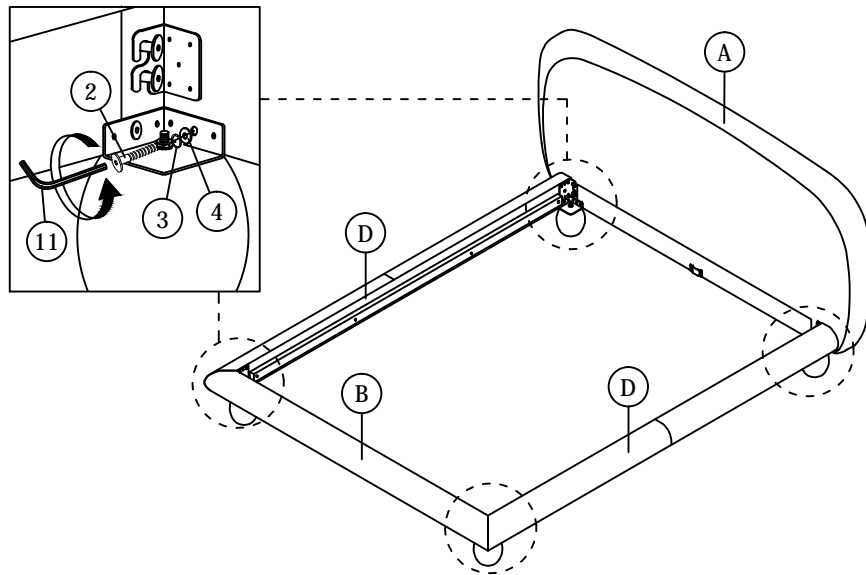

STEP 6

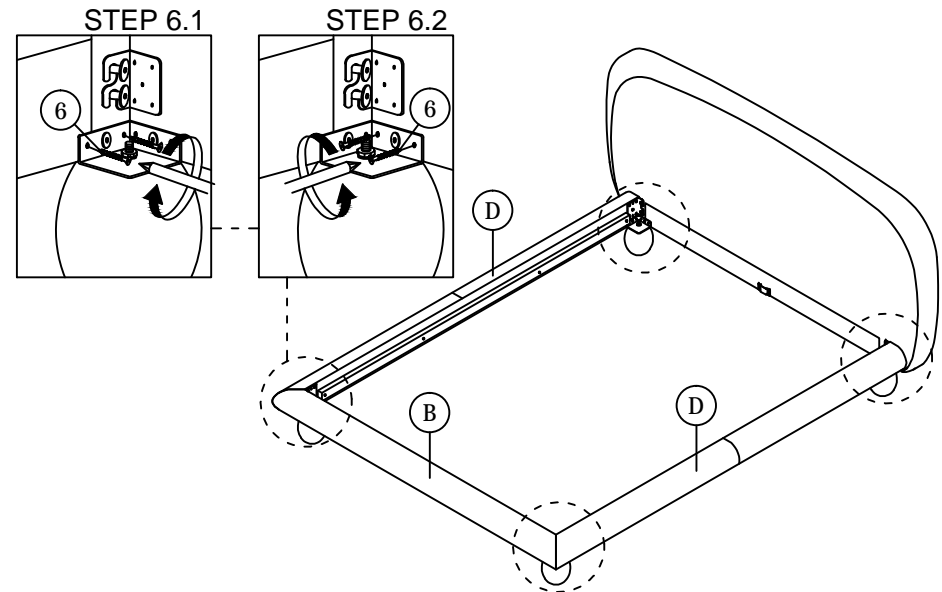

ASSEMBLY INSTRUCTIONS

STEP 7

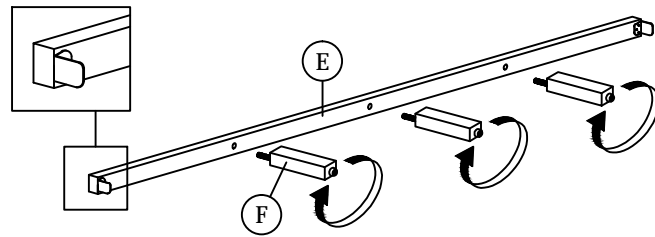

STEP 8

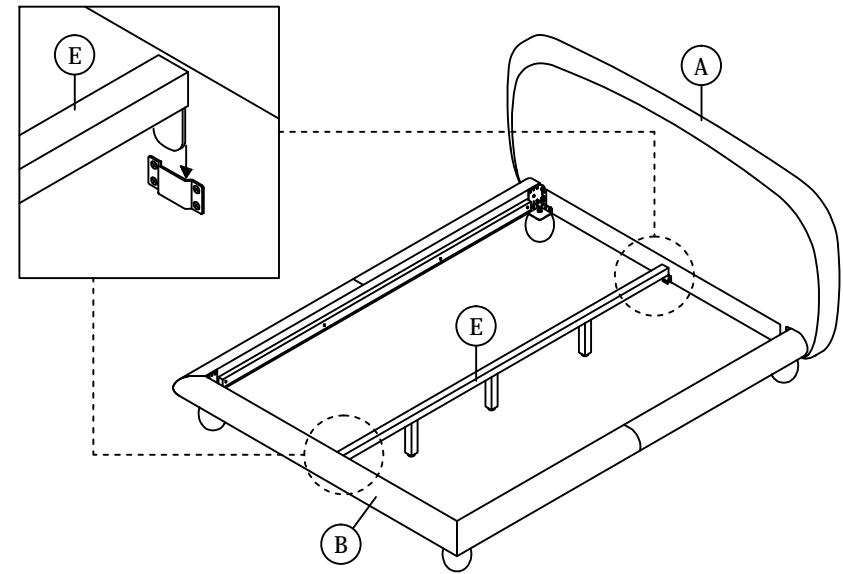

STEP 9

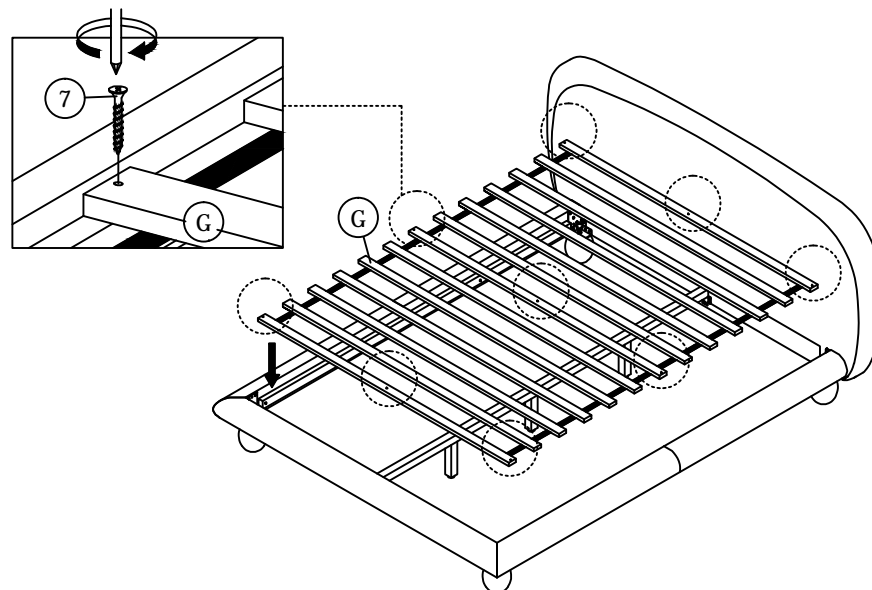

STEP 10

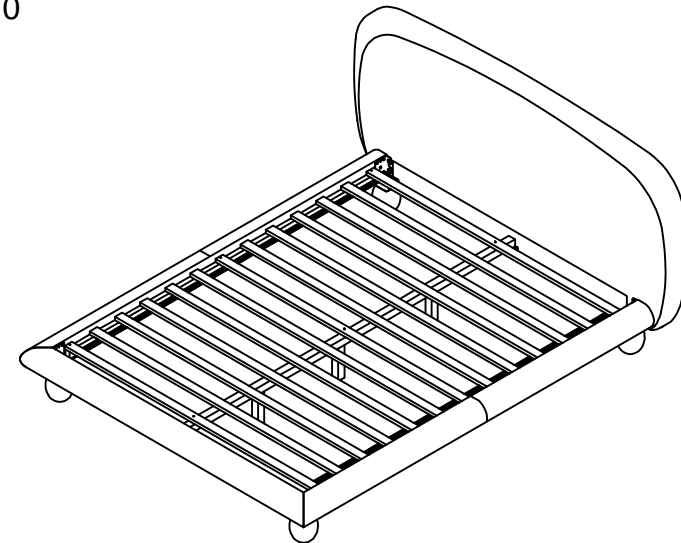

* When moving the bed position, the center support legs must be adjusted or straightened to avoid any broken problems.