





















ASSEMBLY INSTRUCTION

ITEM : ALESHA - KB

NO	PART LIST	QTY
1	 HEADBOARD CUSHION	1PC
2	 RIGHT HEADBOARD LEG WITH 'R' LABEL	1PC
3	 LEFT HEADBOARD LEG WITH 'L' LABEL	1PC
4	 WINGS	2PCS
5	 FOOTBOARD CUSHION	1PC
6	 FOOTBOARD LEGS	2PCS
7	 SIDE RAIL	2PCS
8	 SIDE RAIL	2PCS
9	 SIDE RAIL SUPPORT LEG	2PCS
10	 SLATS	4PCS
11	 SUPPORT LEGS WITH ADJUSTABLE FEET	8PCS
NO	HARDWARE LIST	QTY
A	 JCBB SCREW M8 X 20	8PCS
B	 JCBC SCREW M6 X 25	8PCS
C	 JCBC SCREW M6 X 35	20PCS
D	 JCBC SCREW M6 X 70	2PCS
E	 WOOD DOWEL	2PCS
F	 SPRING WASHER	20PCS
G	 FLAT WASHER	20PCS
H	 SCREW M4 X 32mm	8PCS
I	 L - KEY M5 X 65mm	1PC
J	 L - KEY M4 X 65mm	1PC

STEP 1

Begin assembly by attaching each headboard leg (2) & (3) to the bottom of headboard cushion (1) by aligning the hole and securing with 3 Allen bolts (C), 3 spring washer (F), 3 flat washer (G) per leg using L-key (J).

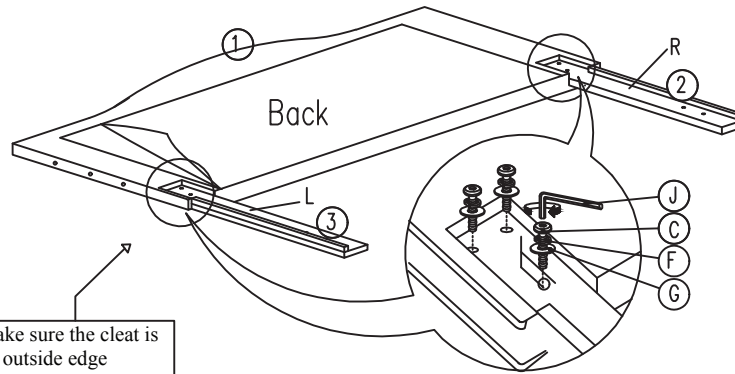

Make sure the cleat is on outside edge

STEP 3

Attach each footboard legs (6) to the bottom of the footboard cushion (5) by inserting a dowel (E) & securing with 1 Allen bolt (D) per leg using L-key (J).

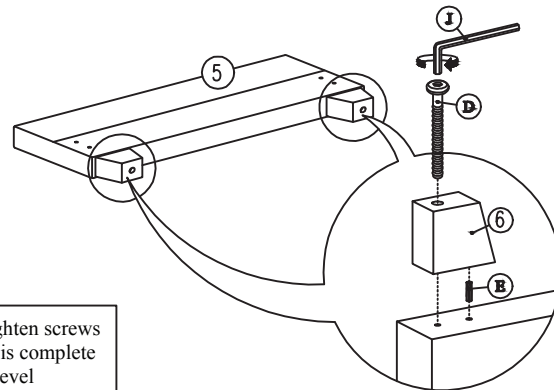

Do not fully tighten screws until assembly is complete and the bed is level

STEP 2

Attaching each wing (4) to each side of headboard cushion (1) by aligning the hole and securing with 3 Allen bolts (C), 3 spring washer (F), 3 flat washer (G) per side using L-key (J).

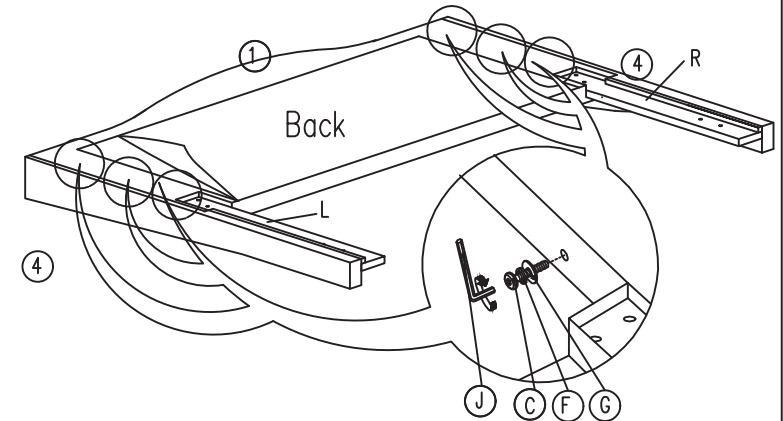

STEP 4

Attach the side rail support leg (9) to the join of the side rail (7) & side rail (8) by securing with 4 Allen bolts (B), 4 spring washer (F), 4 flat washer (G) per support using L-key (J).

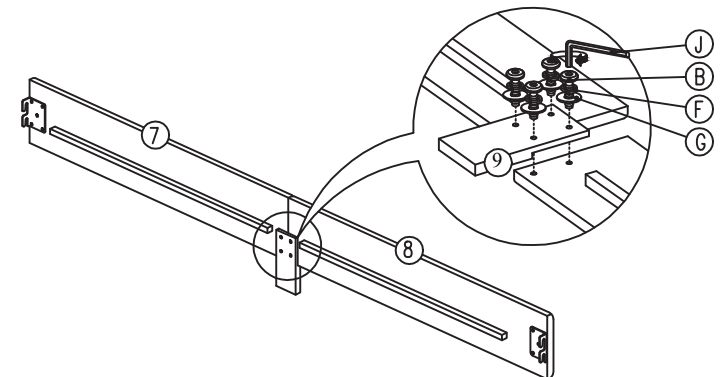

Do not fully tighten screws until assembly is complete and the bed is level

ASSEMBLY INSTRUCTION

STEP 5

Attach side rail to the headboard leg (2) & (3) & Footboard (5). Aligning holes and securing with 2 Allen bolts (A) per each and using L-key (I). Do not fully tighten bolts for this step.

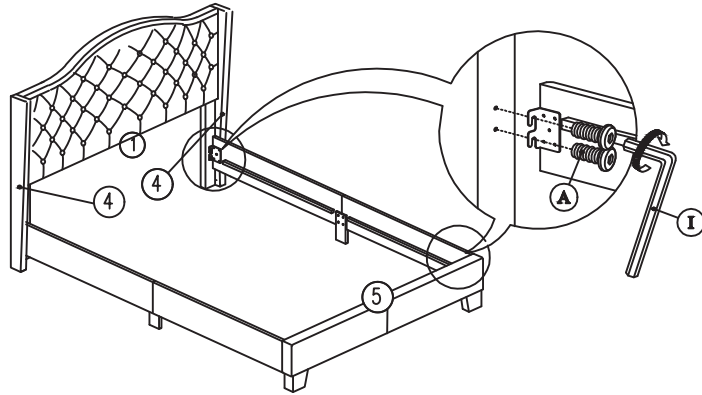

STEP 6

Attach support legs (11) to slat (10) by securing with 1 Allen bolt (C) per support leg. (2 support legs (11) per slat (10) as shown) Attach slat (10) to side rail by securing with 1 screw (H) per each side. Tighten all screws using philips head screw driver (NOT INCLUDED). Tighten all bolts on step 3 & 4 using L-key (J) & tighten bolts on step 5 using L-key (I).

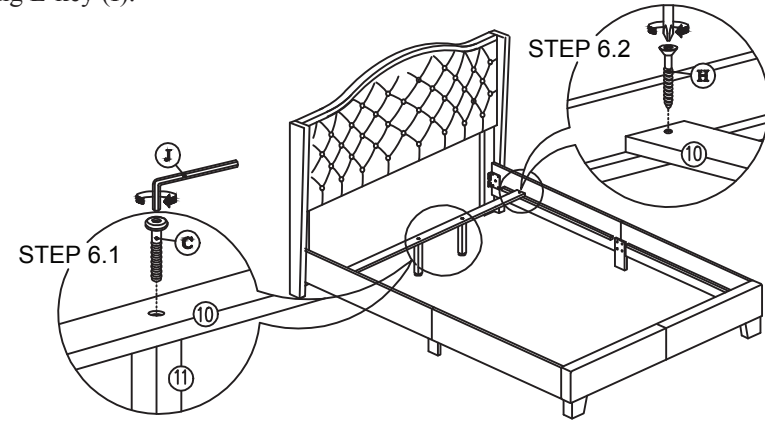

STEP 7

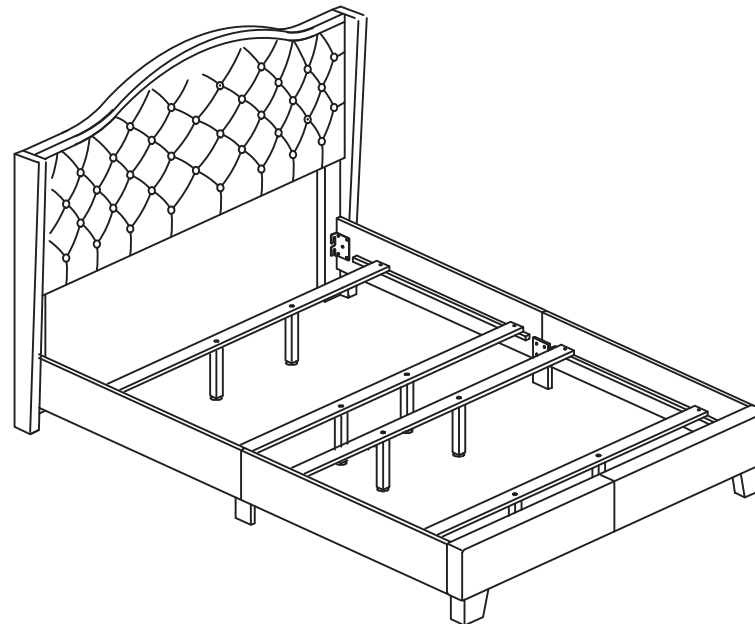

**ASSEMBLY
COMPLETED**

NOTE : AFTER A FEW DAYS OF ASSEMBLY, IT WILL HAVE ACCLIMATIZED TO THE ENVIRONMENT. PLEASE TIGHTEN ALL HARDWARE. CHECK TIGHTNESS OF ALL SCREWS EVERY 6 - 8 WEEKS.