

# ASSEMBLY INSTRUCTION

ABBIE DAYBED-F / ABBIE DAYBED-Q

NO	PART LIST	QTY
1	BACK REST	1PC
2	SIDE PANEL (L)	1PC
3	SIDE PANEL (R)	1PC
4	FRONT SIDE RAIL	1PC
5	BACK SIDE RAIL	1PC
6	LEG	4PCS
7	SLAT <small>7pcs</small>	2 SET
8	SLAT SUPPORT	1PC
9	SUPPORT LEG	2PCS
ITEM	HARDWARE	QTY
A	JCBB SCREW M8 x 20MM	12PCS
B	JCBC SCREW M6 x 50MM	8PCS
C	SPRING WASHER	4PCS
D	FLAT WASHER	4PCS
E	SCREW M4 x 32MM	14PCS
F	L - KEY M4 x 65MM	1PC
G	L - KEY M5 x 65MM	1PC

## STEP 1

Begin assembly by attaching each Leg (6) to the bottom of the Side Panel (2) & (3) securing with 2 Allen Bolt (B) per panel using L-key (F).

Then attach the Back Side Rail (5) to the Side Panel (2) & (3) by aligning holes and securing with 2 Allen Bolts (A) per each side using L-key (G).

And attach the Front Side Rail (4) also by aligning holes and securing with 4 Allen Bolts (A) per side using L-key (G).

(DO NOT FULLY TIGHTEN BOLTS FOR THIS STEP)

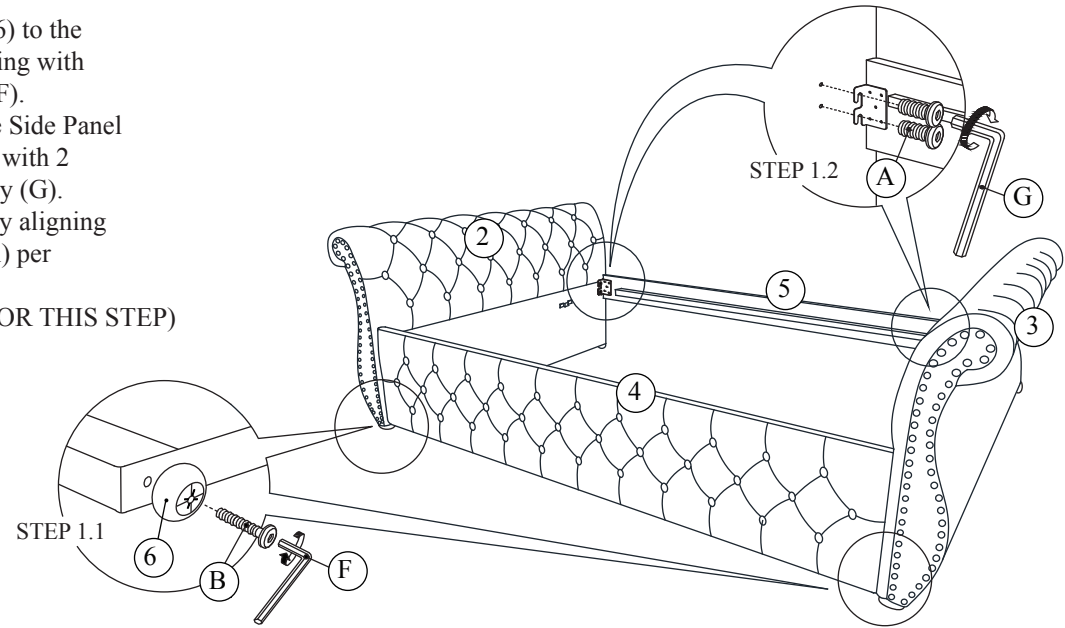

## STEP 2

Attach the Back Rest (1) to the back of each Side Panel (2) & (3) by aligning the hole and securing with 2 Allen Bolts (B), 2 Spring Washer (C), 2 Flat Washer (D) from the back side per each end using L-key (F).

(DO NOT FULLY TIGHTEN BOLTS FOR THIS STEP)

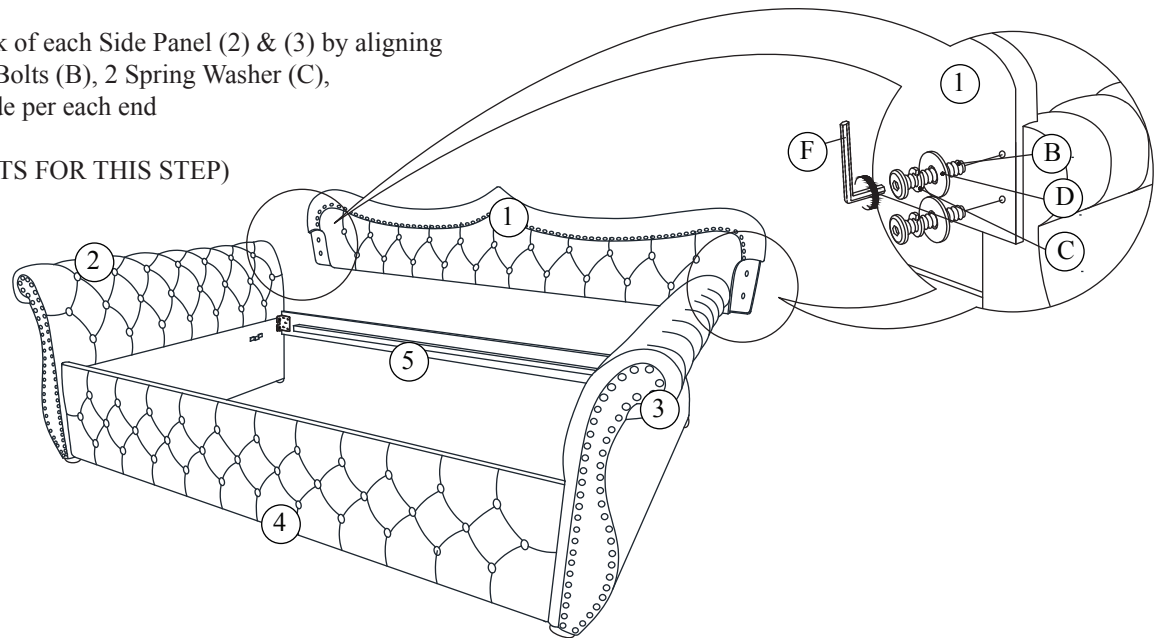

Please do not tighten the hardware until the entire assembly is completed.

# ASSEMBLY INSTRUCTION

## STEP 3

Secure 2 Support Leg (9) to the Slat Support (8) as shown on step 3.1. Insert the pre-set metal on Slat Support (8) to the metal bracket on each side of Side Panel (2) & (3). Then securing the metal bracket as shown in step 3.3 with 1 Screw (E) each side using Phillips Head Screwdriver (NOT INCLUDED)

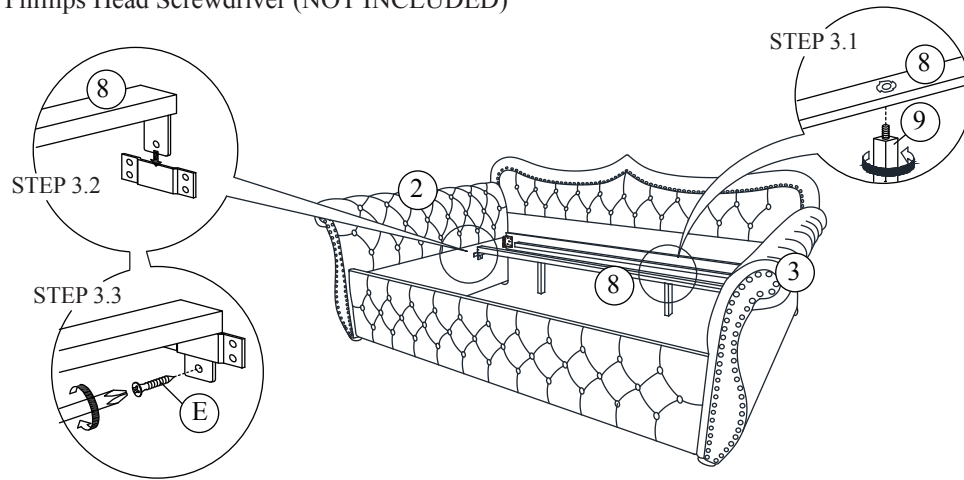

## STEP 5

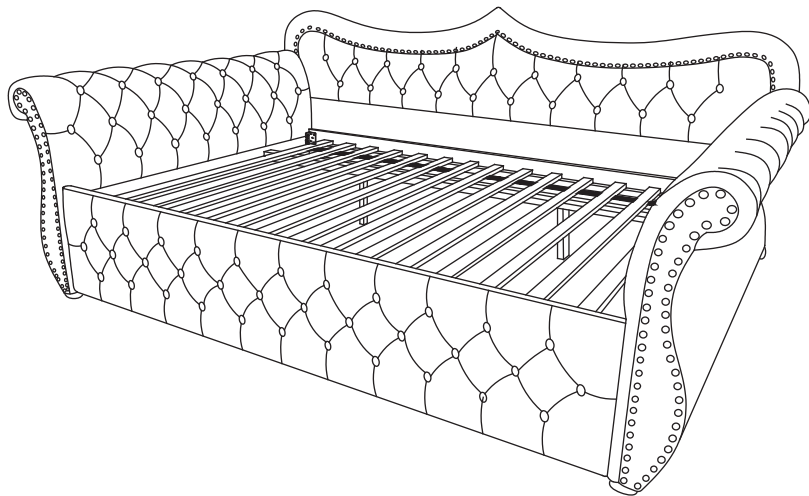

ASSEMBLY  
COMPLETE

## STEP 4

Tighten All Bolts from step 1 to step 3 by using L-key (F) & (G) that has been provided. Attached slat (7) to Front Side Rail (4) & Back Side Rail (5) by unrolling and securing with 6 Screw (E) per set. Securing Slat (7) to Back Side Rail (5) with 2 Screw (E) per each side as step 4.1. Following by step 4.2, using 1 Screw (E) to secure Slat (7) to Front Side Rail (4). Repeat the same step to attach another set of slat (7).

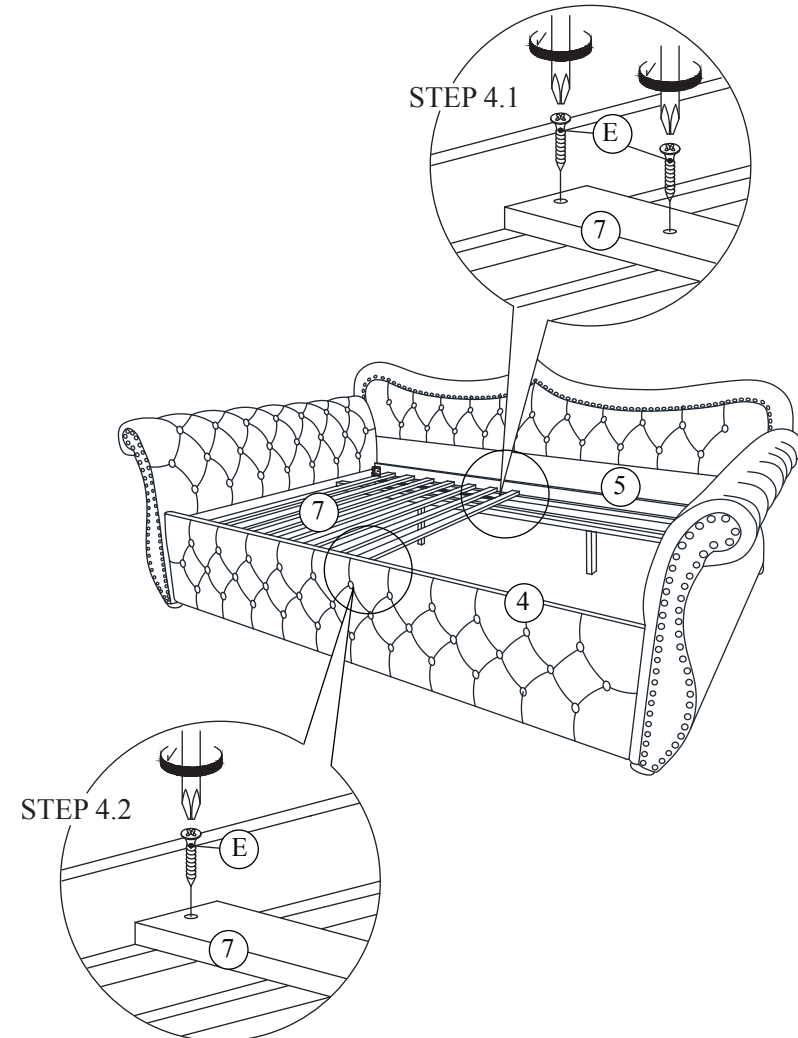

Please do not tighten the hardware until the entire assembly is completed.