













# ASSEMBLY INSTRUCTION

ITEM : B9250-T-BED

## BOX OF BED BED

ITEM	DRAWING	DESCRIPTION	QTY
A		HEAD BOARD	1
B		HEAD BOARD LEG (L)	1
C		HEAD BOARD LEG (R)	1
D		FOOT BOARD	1
E		SIDE RAIL	2
F		SIDE RAIL	2
G		SLAT	4
H		SIDE RAIL SUPPORT LEG	2

## BOX OF BED HARDWARE LIST

ITEM	DRAWING	DESCRIPTION	QTY
1		JCBB SCREW M8x16mm	8
2		JCBB SCREW M8x30mm	8
3		JCBB SCREW M8x40mm	6
4		CSK SCREW M4x32mm	8
5		L-KEY M5x65mm	1

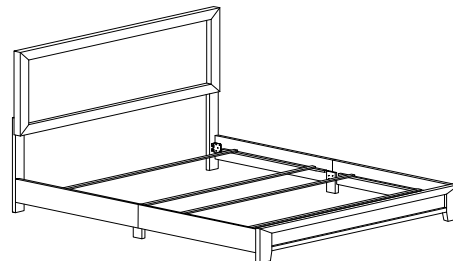

COMPLETED BED ASSEMBLY

## STEP 1

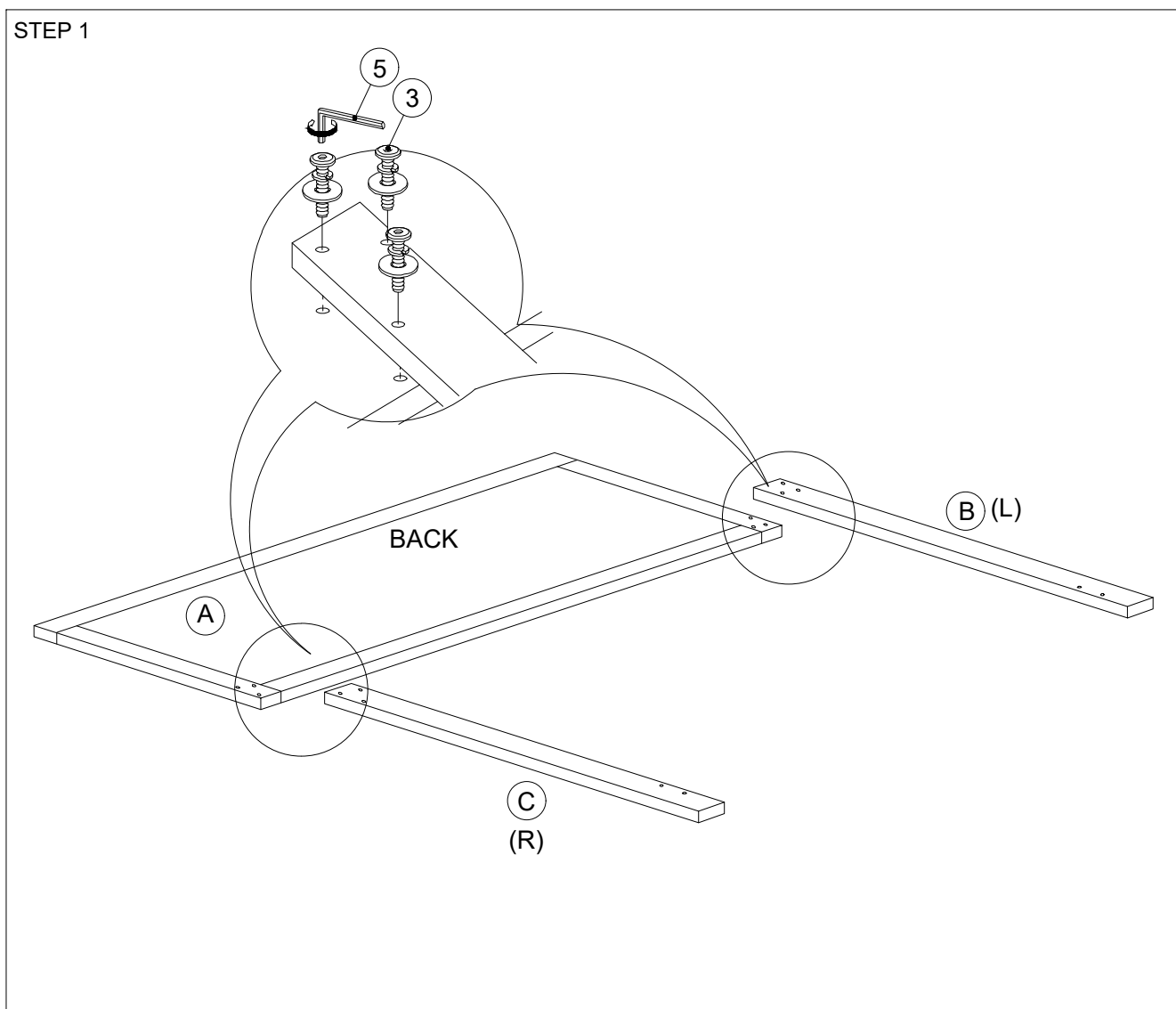

THE HARDWARE IS LOCATED IN THE PACKING ITEMS

PAGE 01 OF 02

NOTE : MUST TIGHT SCREWS PERIODICALL. WITH USE SCREWS MAY BECOME LOOSE.  
CHECK TIGHNESS OF ALL SCREWS EVERY 6-8 WEEKS.

MADE IN MALAYSIA

# ASSEMBLY INSTRUCTION

ITEM : B9250-T-BED

## STEP 2

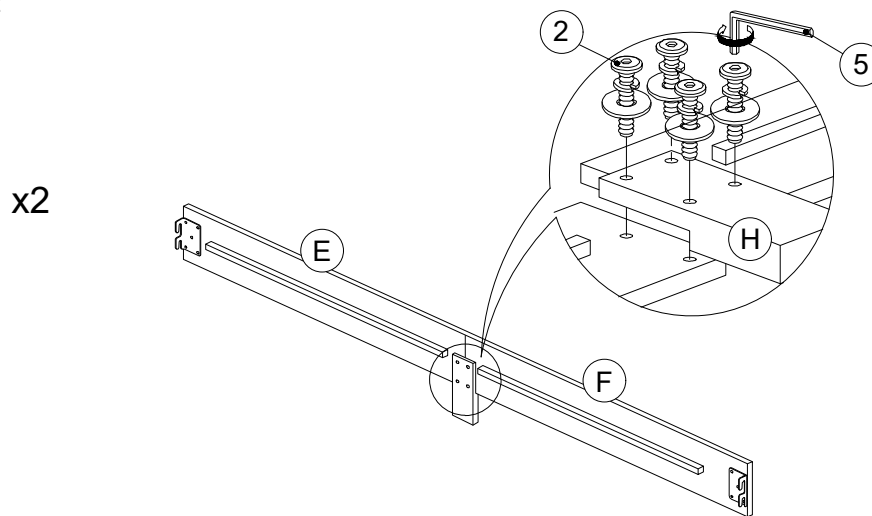

## STEP 3

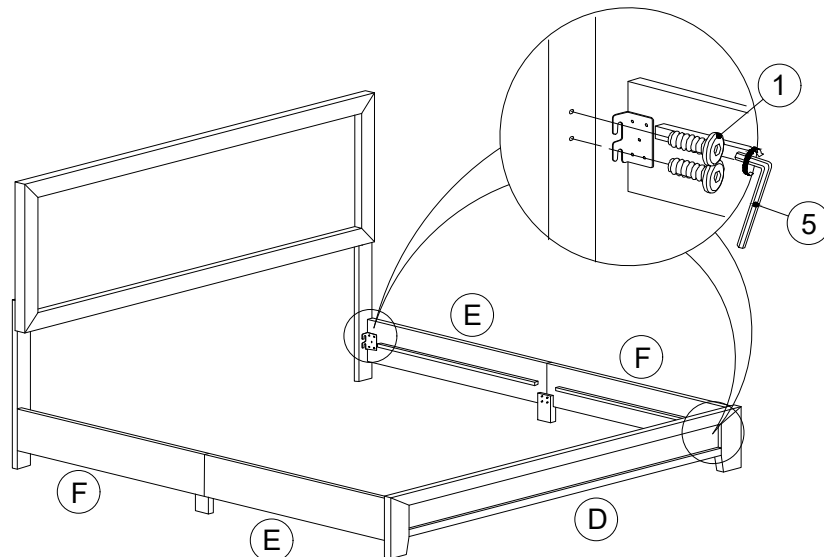

## STEP 4

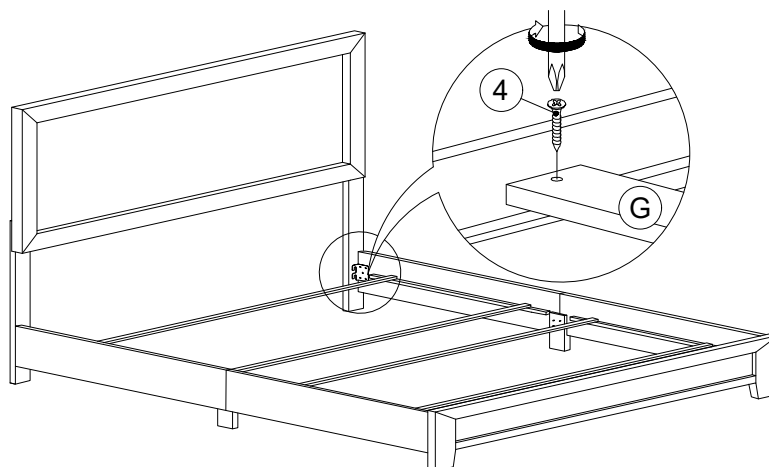

THE HARDWARE IS LOCATED IN THE PACKING ITEMS

PAGE 02 OF 02

NOTE : MUST TIGHT SCREWS PERIODICALL. WITH USE SCREWS MAY BECOME LOOSE.  
CHECK TIGHNESS OF ALL SCREWS EVERY 6-8 WEEKS.

MADE IN MALAYSIA