

# ASSEMBLY INSTRUCTIONS

ITEM : B9230-K-HBFB / B9230-KQ-RAIL  
KING BED

**BOX 1 OF HEADBOARD/FOOTBOARD PART LIST**

ITEM	DRAWING	DESCRIPTION	QTY
A		HEADBOARD	1
B		HEADBOARD LEG (R)	1
C		HEADBOARD LEG (L)	1
D		FOOTBOARD	1
E		FOOTBOARD LEG (R)	1
F		FOOTBOARD LEG (L)	1
G		SLAT	4
H		CENTER SUPPORT	8

**BOX 1 OF HEADBOARD/FOOTBOARD HARDWARE LIST**

ITEM	DRAWING	DESCRIPTION	QTY
1		JCBB SCREW M8 x 16MM	8
2		JCBB SCREW M8 x 40MM	8
3		JCBC SCREW M6 x 40MM	4
4		CSK SCREW M4 x 32MM	8
5		ALLEN KEY M4	1
6		ALLEN KEY M5	1

**ASSEMBLY TOOLS REQUIRED**

	SCREWDRIVER (NOT PROVIDED)	1
--	----------------------------	---

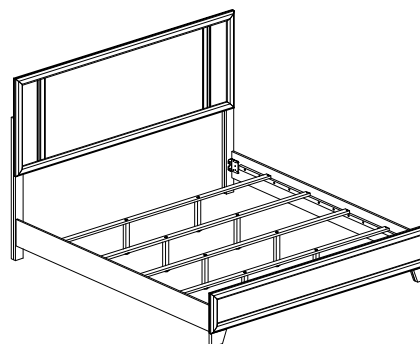

**COMPLETED ASSEMBLY**

**BOX 2 OF SIDE RAIL PART LIST**

I		SIDE RAIL	2
---	--	-----------	---

**STEP 1**

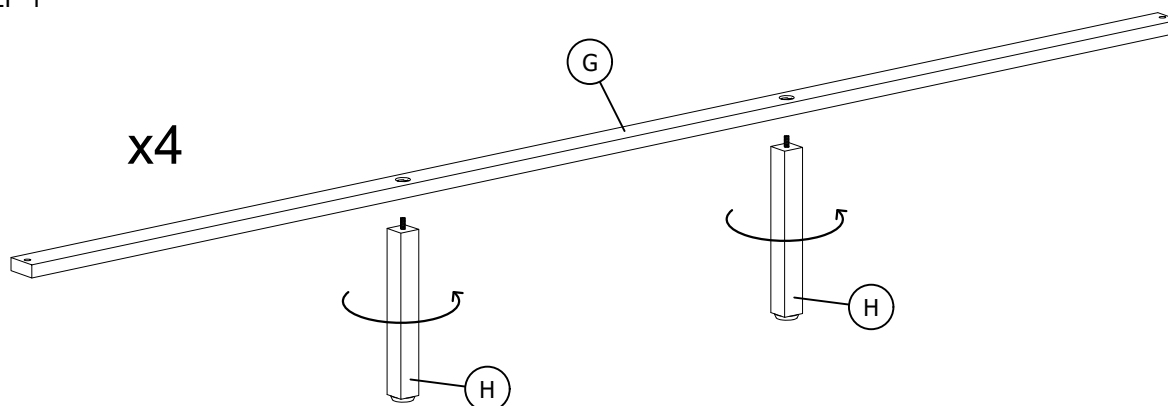

**STEP 2**

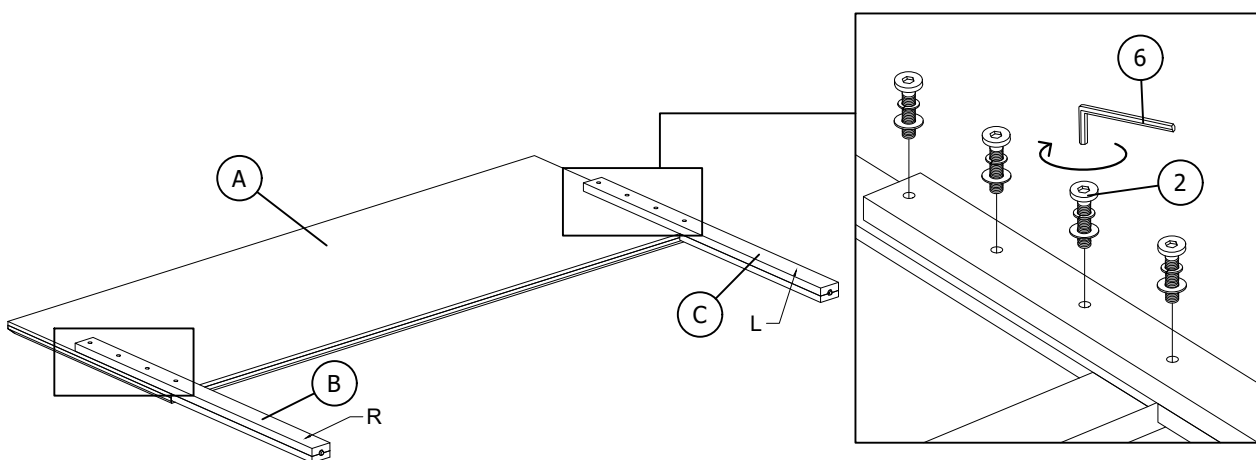

THE HARDWARE IS LOCATED IN THE PACKING ITEMS

PAGE 01 OF 02

NOTE : MUST TIGHT SCREWS PERIODICALLY. WITH USE SCREWS MAY BECOME LOOSE. CHECK TIGHTNESS OF ALL SCREWS EVERY 6-8 WEEKS.

MADE IN MALAYSIA

# ASSEMBLY INSTRUCTIONS

ITEM : B9230-K-HBFB / B9230-KQ-RAIL  
KING BED

## STEP 3

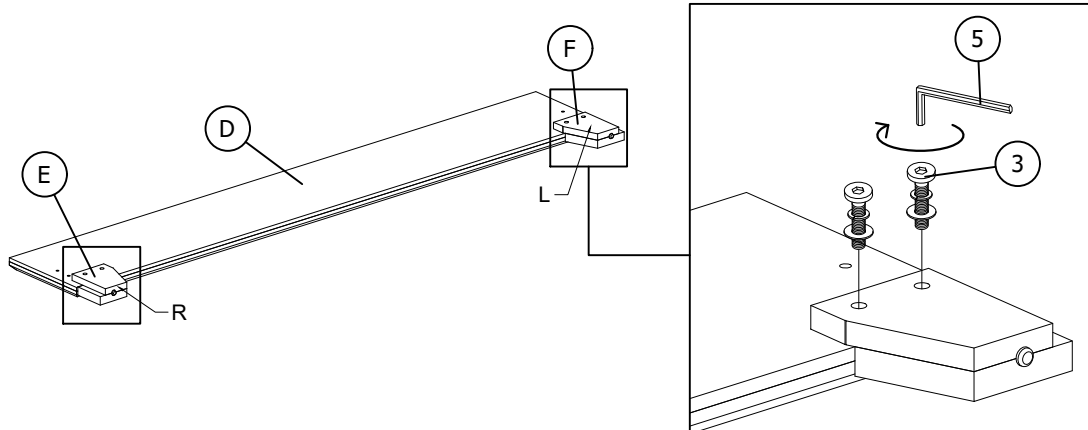

## STEP 4

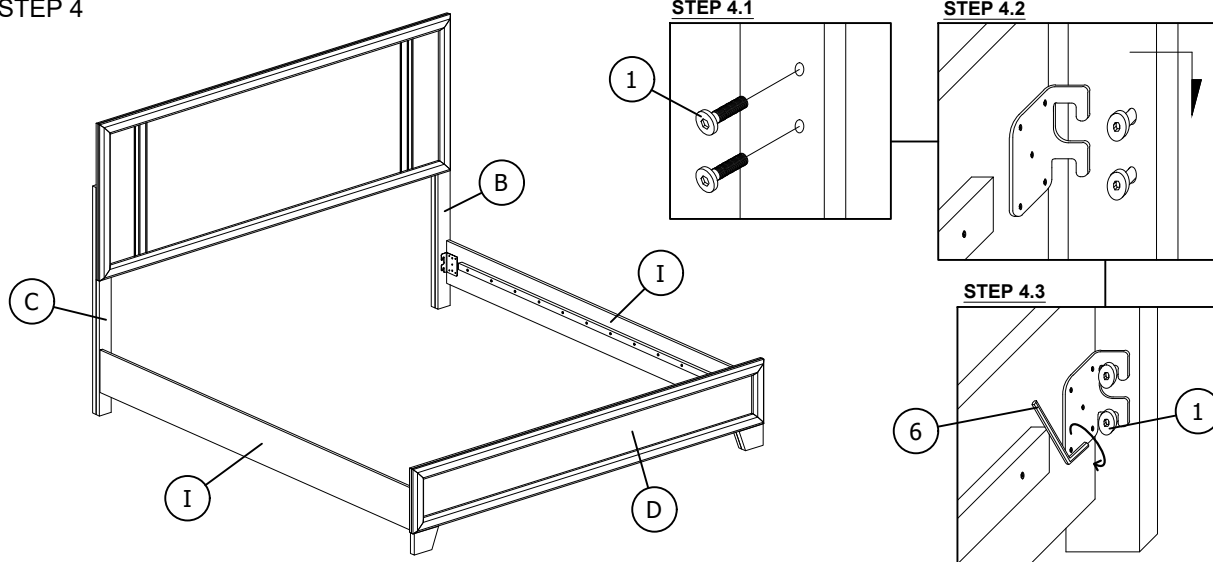

## STEP 5

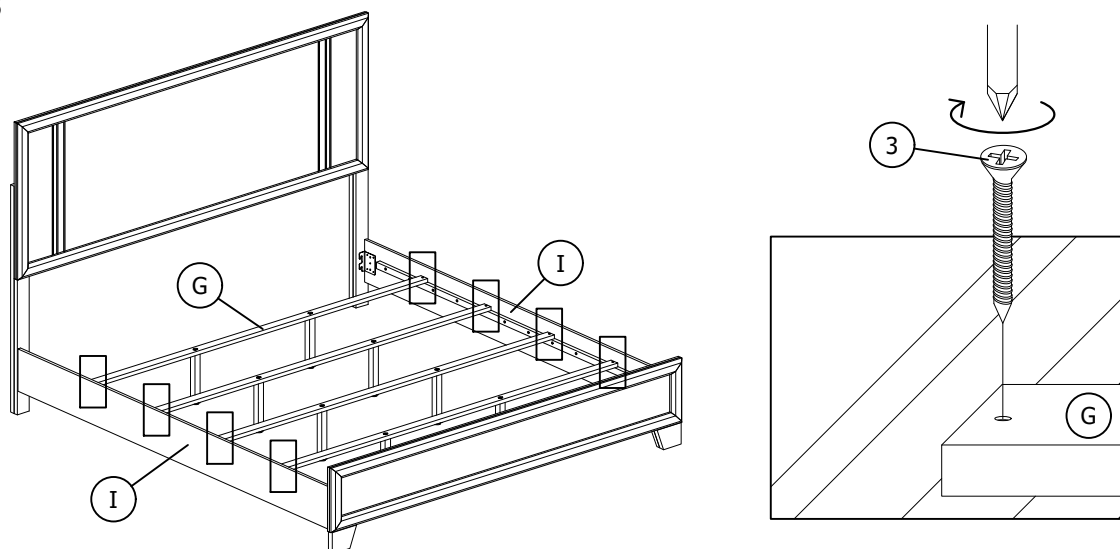

THE HARDWARE IS LOCATED IN THE PACKING ITEMS

PAGE 02 OF 02

NOTE : MUST TIGHT SCREWS PERIODICALLY. WITH USE SCREWS MAY BECOME LOOSE.  
CHECK TIGHTNESS OF ALL SCREWS EVERY 6-8 WEEKS.

MADE IN MALAYSIA