

ITEM NO : B8250 - Q - HBFBI SIENNA QUEEN HB + FB

+ H/F CANOPY BARS





B8250 - Q - BASE SIENNA QUEEN BASE

B8250 - KQ - RAIL SIENNA K/Q RAIL + SIDE CANOPY

+ POST

ASSEMBLY INSTRUCTIONS

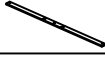



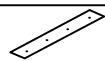

**(BOX 1)
BOX OF HEADBOARD & FOOTBOARD**

ITEM	DRAWING	DESCRIPTION	QTY
A		HEADBOARD FRAME	1
B		FOOTBOARD FRAME	1
C		WOODEN SUPPORT	4
D		WOODEN SLAT	4
E		TOP RAIL	2







**(BOX 2)
BOX OF PANEL**

ITEM	DRAWING	DESCRIPTION	QTY
F		CONCEAL PANEL	5

**(BOX 3)
BOX OF SIDE RAIL**

ITEM	DRAWING	DESCRIPTION	QTY
G1		LEFT HEADBOARD LEG	1
G2		RIGHT HEADBOARD LEG	1
H1		LEFT FOOTBOARD LEG	1
H2		RIGHT FOOTBOARD LEG	1
I		SIDE RAIL	2
J		SIDE RAIL	2

**(BOX 1)
HARDWARE LIST**

ITEM	DRAWING	DESCRIPTION	QTY
1		ALLEN WRENCH (M4 x 110mm)	1
2		WOOD DOWEL (M10 x 40mm)	18
3		CONNECTION BOLT (M6 x 70mm) (FOR HB & FB POST)	18
4		CONNECTION BOLT (M6 x 50mm) (FOR SR)	4
5		ROUND HEAD SCREW (M4 x 20mm)	20
6		FLAT HEAD SCREW (M4 x 32mm)	8
7		SCREW DRIVER(*)	1

The manufacturer does not provide item 7.

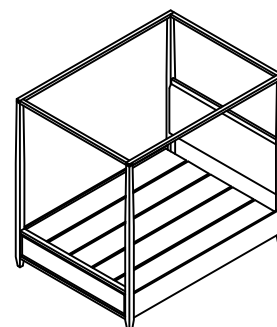

**COMPLETED QUEEN BED
ASSEMBLY**

THE HARDWARE IS LOCATED IN THE PACKING ITEMS

NOTE : MUST TIGHTEN SCREWS PERIODICALLY. WITH USE SCREW MAY BECOME LOOSE. CHECK TIGHTNESS OF ALL SCREWS EVERY 6-8 WEEKS.

CLEANING INSTRUCTION

After assembly, clean & polish the completed parts if necessary with soft cloth and industrial recognized furniture polish

ITEM NO : B8250 - Q - HBFBI SIENNA QUEEN HB + FB

+ H/F CANOPY BARS

B8250 - Q - BASE SIENNA QUEEN BASE

B8250 - KQ - RAIL SIENNA K/Q RAIL + SIDE CANOPY

+ POST

ASSEMBLY INSTRUCTIONS

STEP 1

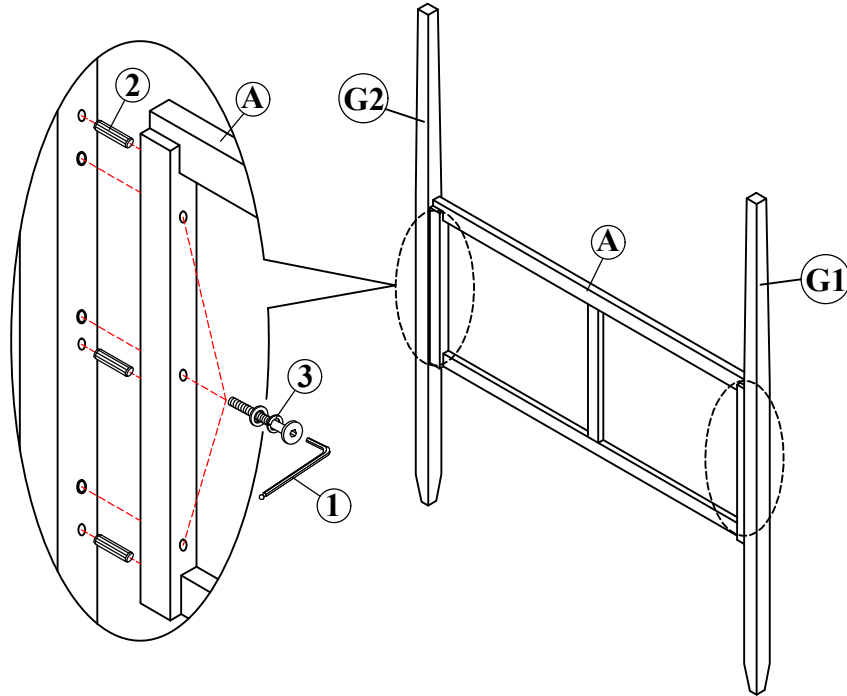

STEP 2

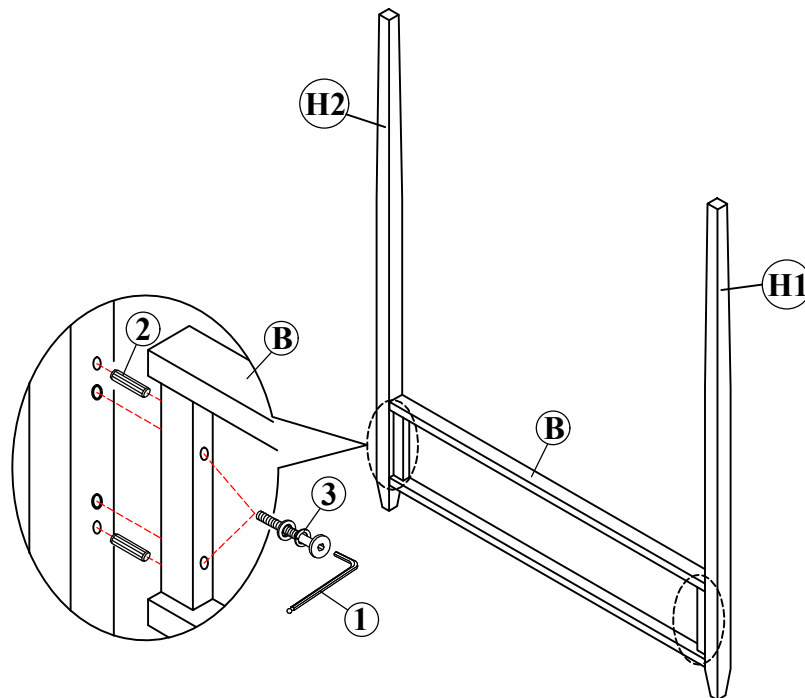

THE HARDWARE IS LOCATED IN THE PACKING ITEMS

NOTE : MUST TIGHTEN SCREWS PERIODICALLY. WITH USE SCREW MAY BECOME LOOSE.
CHECK TIGHTNESS OF ALL SCREWS EVERY 6-8 WEEKS.

CLEANING INSTRUCTION

After assembly, clean & polish the completed parts if necessary with soft cloth and industrial recognized furniture polish

MADE IN MALAYSIA

ITEM NO : B8250 - Q - HBFB SIENNA QUEEN HB + FB

+ H/F CANOPY BARS

B8250 - Q - BASE SIENNA QUEEN BASE

B8250 - KQ - RAIL SIENNA K/Q RAIL + SIDE CANOPY

+ POST

ASSEMBLY INSTRUCTIONS

STEP 3

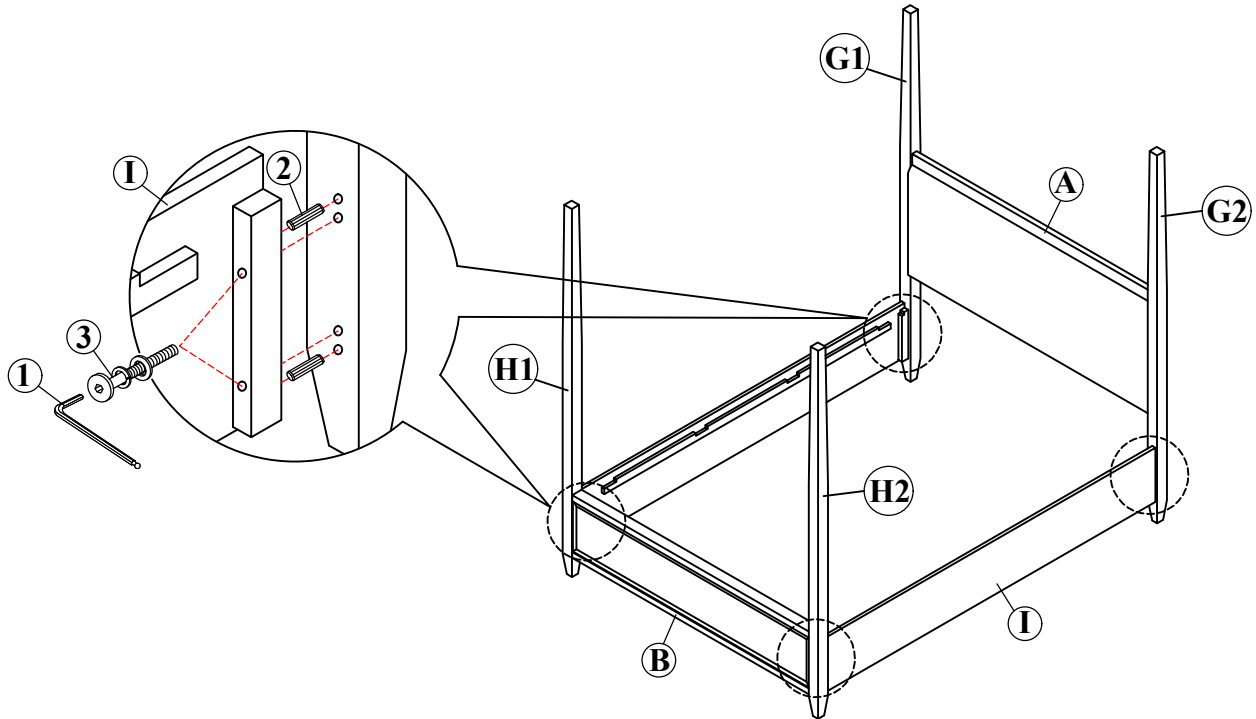

STEP 4

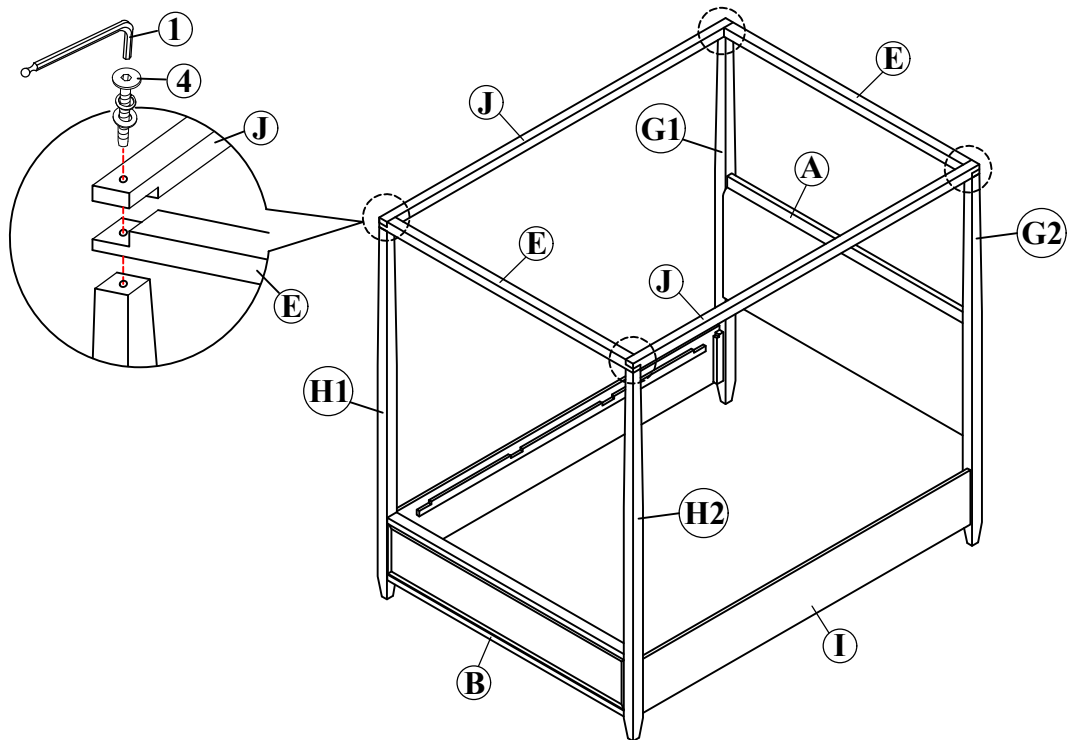

THE HARDWARE IS LOCATED IN THE PACKING ITEMS

NOTE : MUST TIGHTEN SCREWS PERIODICALLY. WITH USE SCREW MAY BECOME LOOSE.
CHECK TIGHTNESS OF ALL SCREWS EVERY 6-8 WEEKS.

CLEANING INSTRUCTION

After assembly, clean & polish the completed parts if necessary with soft cloth and industrial recognized furniture polish

MADE IN MALAYSIA

ITEM NO : B8250 - Q - HBFB SIENNA QUEEN HB + FB

+ H/F CANOPY BARS

B8250 - Q - BASE SIENNA QUEEN BASE

B8250 - KQ - RAIL SIENNA K/Q RAIL + SIDE CANOPY

+ POST

ASSEMBLY INSTRUCTIONS

STEP 5

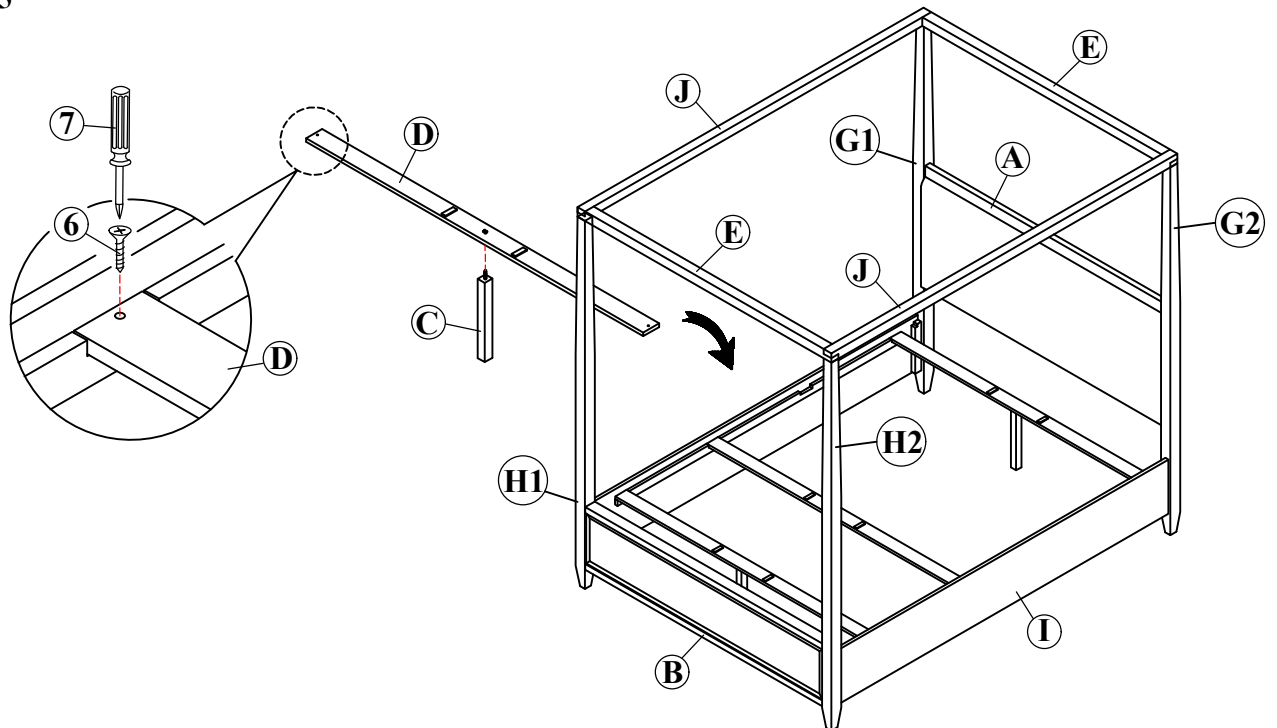

STEP 6

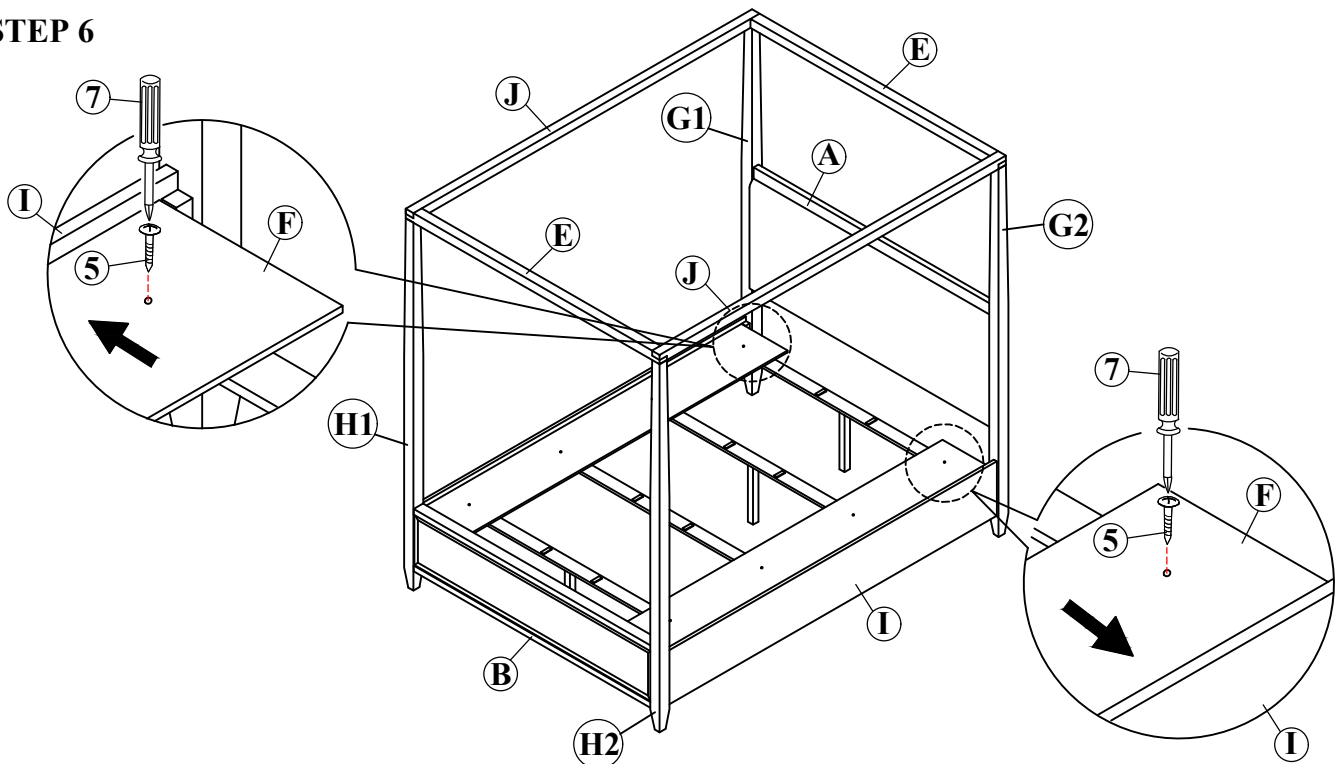

THE HARDWARE IS LOCATED IN THE PACKING ITEMS

NOTE : MUST TIGHTEN SCREWS PERIODICALLY. WITH USE SCREW MAY BECOME LOOSE.
CHECK TIGHTNESS OF ALL SCREWS EVERY 6-8 WEEKS.

CLEANING INSTRUCTION

After assembly, clean & polish the completed parts if necessary with soft cloth and industrial recognized furniture polish

MADE IN MALAYSIA

ITEM NO : B8250 - Q - HBFBI SIENNA QUEEN HB + FB

+ H/F CANOPY BARS

B8250 - Q - BASE SIENNA QUEEN BASE

B8250 - KQ - RAIL SIENNA K/Q RAIL + SIDE CANOPY

+ POST

ASSEMBLY INSTRUCTIONS

STEP 7

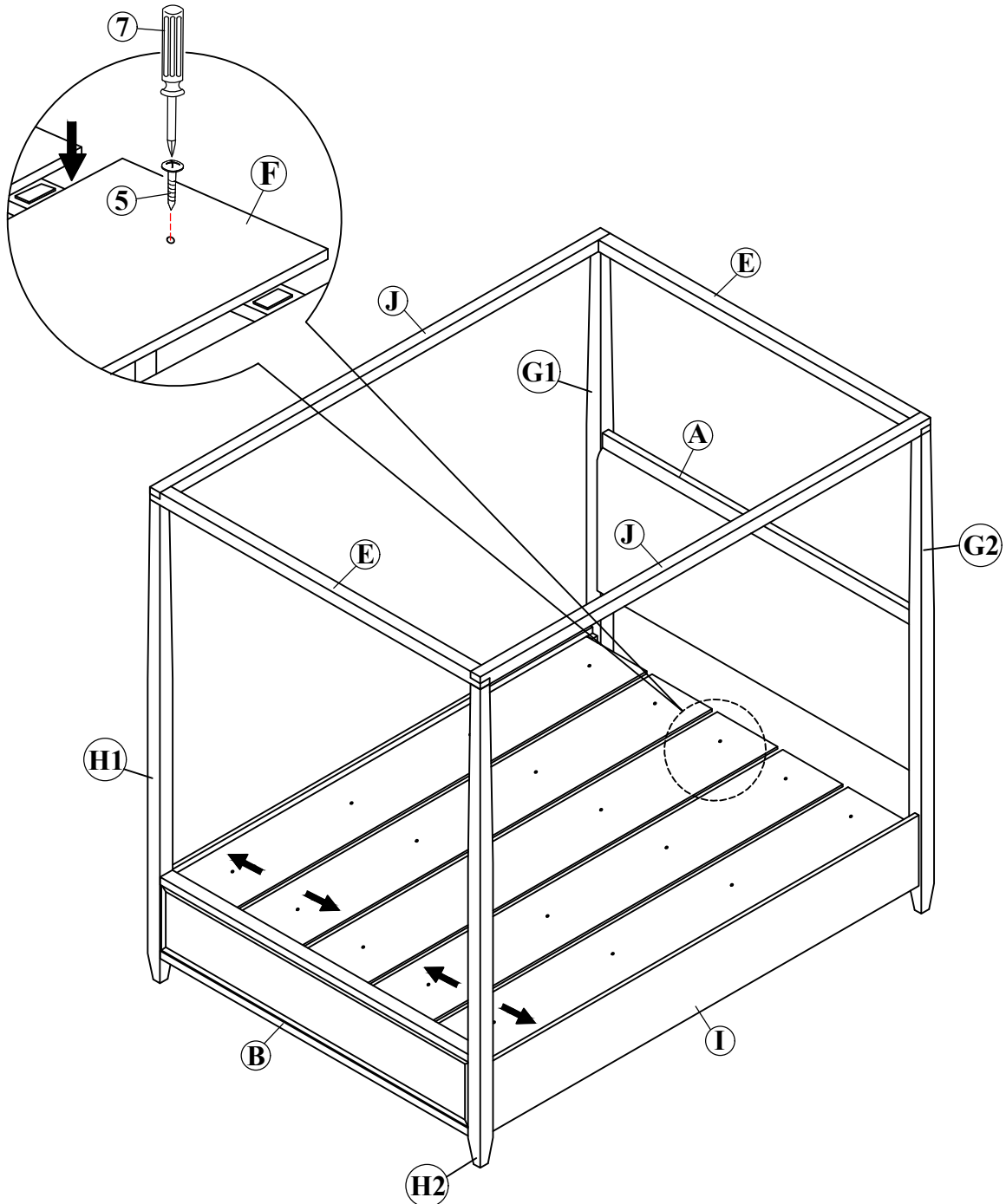

THE HARDWARE IS LOCATED IN THE PACKING ITEMS

NOTE : MUST TIGHTEN SCREWS PERIODICALLY. WITH USE SCREW MAY BECOME LOOSE.
CHECK TIGHTNESS OF ALL SCREWS EVERY 6-8 WEEKS.

CLEANING INSTRUCTION

After assembly, clean & polish the completed parts if necessary with soft cloth and industrial recognized furniture polish

MADE IN MALAYSIA