











# ASSEMBLY INSTRUCTIONS

ITEM NO : B8160 / B8162 - 9 TV UNIT

## BOX OF TV UNIT

ITEM	DRAWING	DESCRIPTION	QTY
A		TV UNIT	1
B		TOP PANEL	1
C		SIDE PANEL	1
D		CENTER PANEL	2

## (BOX OF TV UNIT) HARDWARE LIST

ITEM	DRAWING	DESCRIPTION	QTY
1		ALLEN WRENCH (M4)	1
2		CAM BOLT (T24)	10
3		CAM NUT (D15 X 9.5mm)	10
4		WOOD DOWEL (M12 x 30mm)	12
5		CONNECTION BOLT (M6 x 40mm) W/WASHER & SPRING WASHER	4
6		Assembly Tool Not Included	1

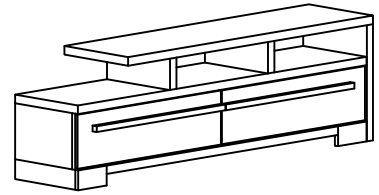

## COMPLETED TV UNIT ASSEMBLY

### STEP 1

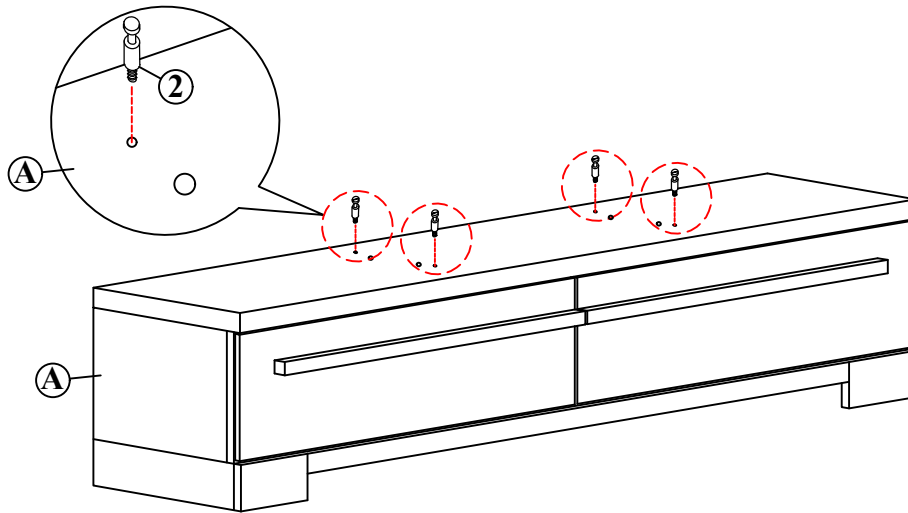

### STEP 2

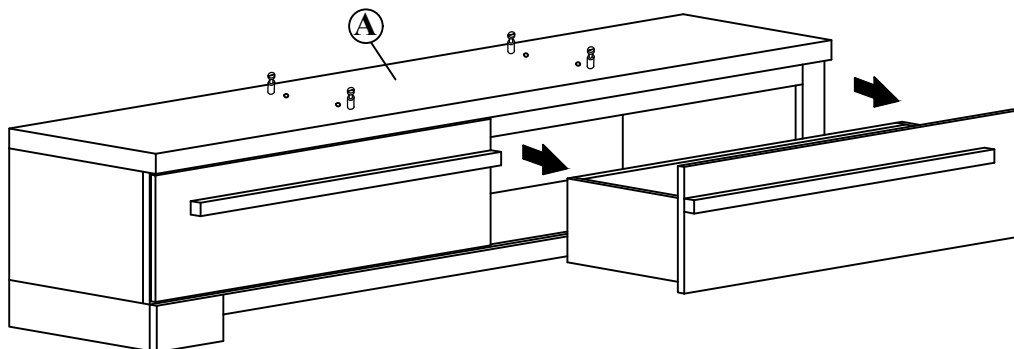

NOTE : ADJUST THE LEVELER ONLY IF IT IS BEING PLACED ON UNEVEN SURFACE.

THE HARDWARE IS LOCATED IN THE PACKING ITEMS

THE ANTI TIPPING HARDWARE IS LOCATED IN THE RIGHT SIDE FRONT DRAWER OF THE TV UNIT.

NOTE : MUST TIGHTEN SCREWS PERIODICALLY. WITH USE SCREW MAY BECOME LOOSE.  
CHECK TIGHTNESS OF ALL SCREW EVERY 6-8 WEEKS.

### CLEANING INSTRUCTION

After assembly, clean & polish the completed parts if necessary with soft cloth and industrial recognized furniture polish

# ASSEMBLY INSTRUCTIONS

ITEM NO : B8160 / B8162 - 9 TV UNIT

## STEP 3

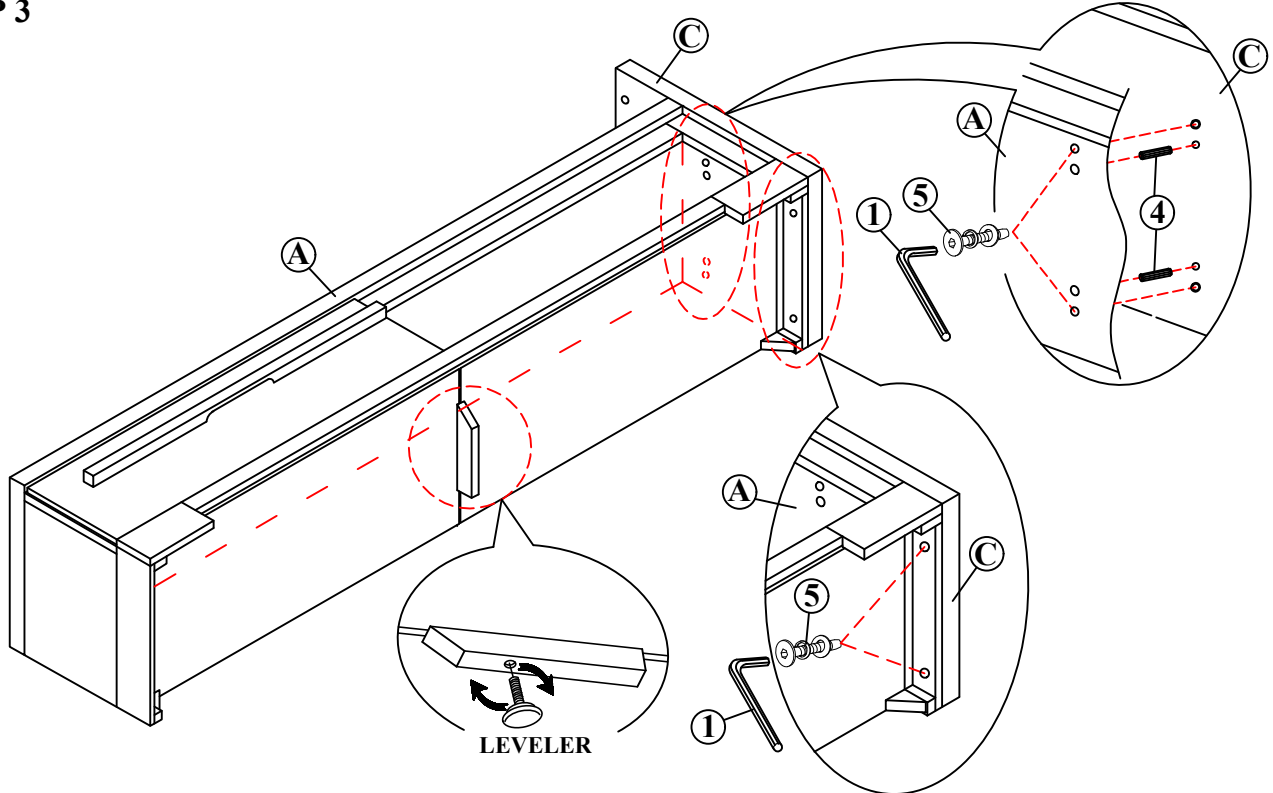

## STEP 4

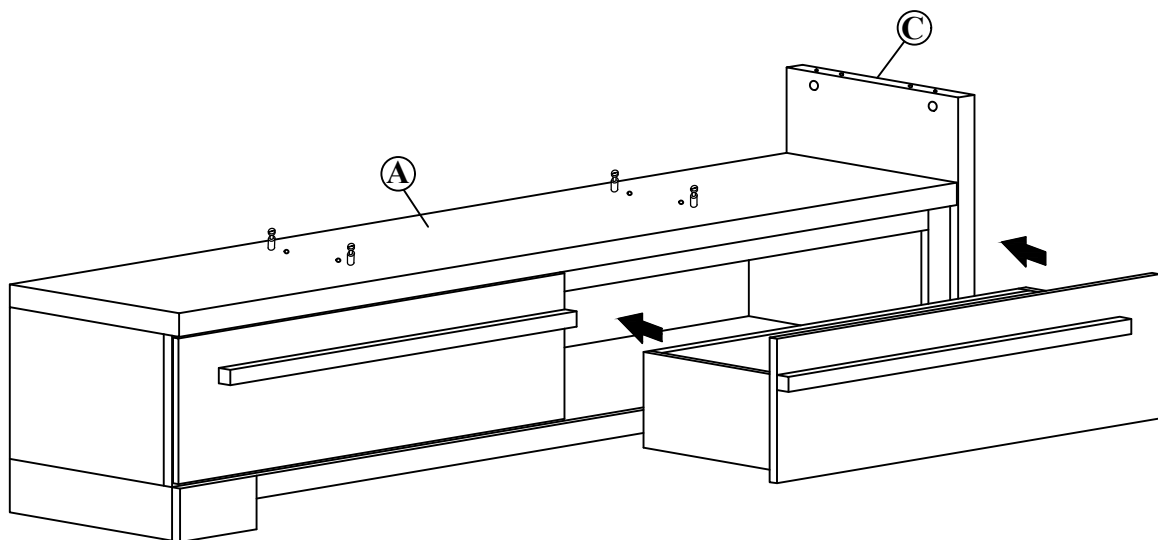

NOTE : ADJUST THE LEVELER ONLY IF IT IS BEING PLACED ON UNEVEN SURFACE.

THE HARDWARE IS LOCATED IN THE PACKING ITEMS

THE ANTI TIPPING HARDWARE IS LOCATED IN THE RIGHT SIDE FRONT DRAWER OF THE TV UNIT.

NOTE : MUST TIGHTEN SCREWS PERIODICALLY. WITH USE SCREW MAY BECOME LOOSE.  
CHECK TIGHTNESS OF ALL SCREW EVERY 6-8 WEEKS.

## CLEANING INSTRUCTION

After assembly, clean & polish the completed parts if necessary with soft cloth and industrial recognized furniture polish

MADE IN MALAYSIA

# ASSEMBLY INSTRUCTIONS

ITEM NO : B8160 / B8162 - 9 TV UNIT

## STEP 5

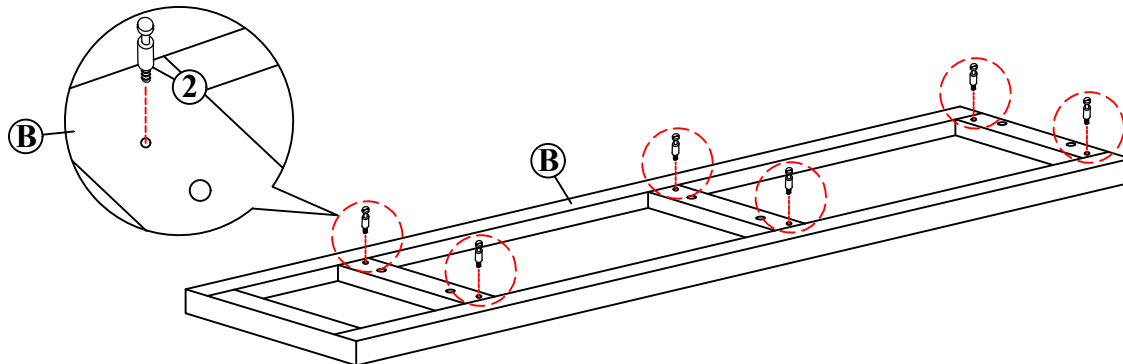

## STEP 6

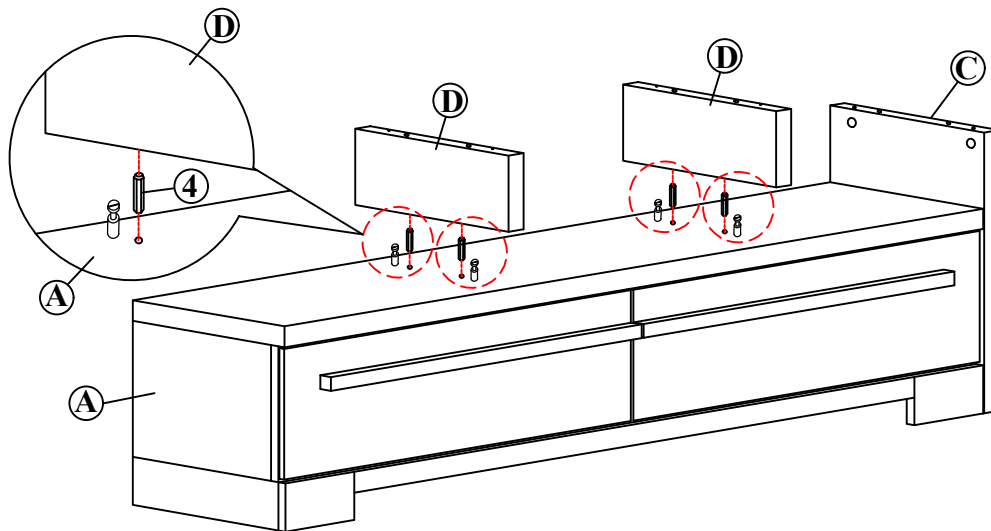

## STEP 7

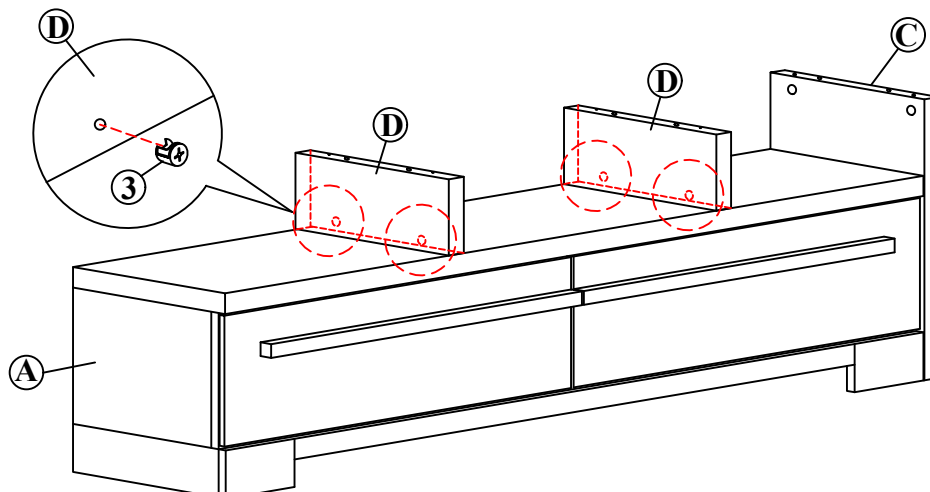

NOTE : ADJUST THE LEVELER ONLY IF IT IS BEING PLACED ON UNEVEN SURFACE.

THE HARDWARE IS LOCATED IN THE PACKING ITEMS

THE ANTI TIPPING HARDWARE IS LOCATED IN THE RIGHT SIDE FRONT DRAWER OF THE TV UNIT.

NOTE : MUST TIGHTEN SCREWS PERIODICALLY. WITH USE SCREW MAY BECOME LOOSE.  
CHECK TIGHTNESS OF ALL SCREW EVERY 6-8 WEEKS.

## CLEANING INSTRUCTION

After assembly, clean & polish the completed parts if necessary with soft cloth and industrial recognized furniture polish

MADE IN MALAYSIA

# ASSEMBLY INSTRUCTIONS

ITEM NO : B8160 / B8162 - 9 TV UNIT

## STEP 8

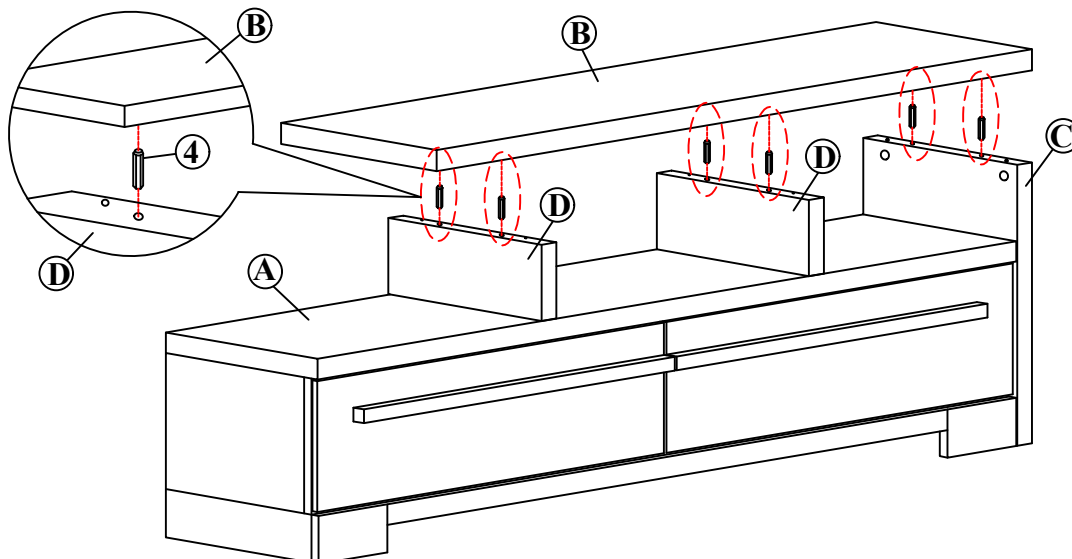

## STEP 9

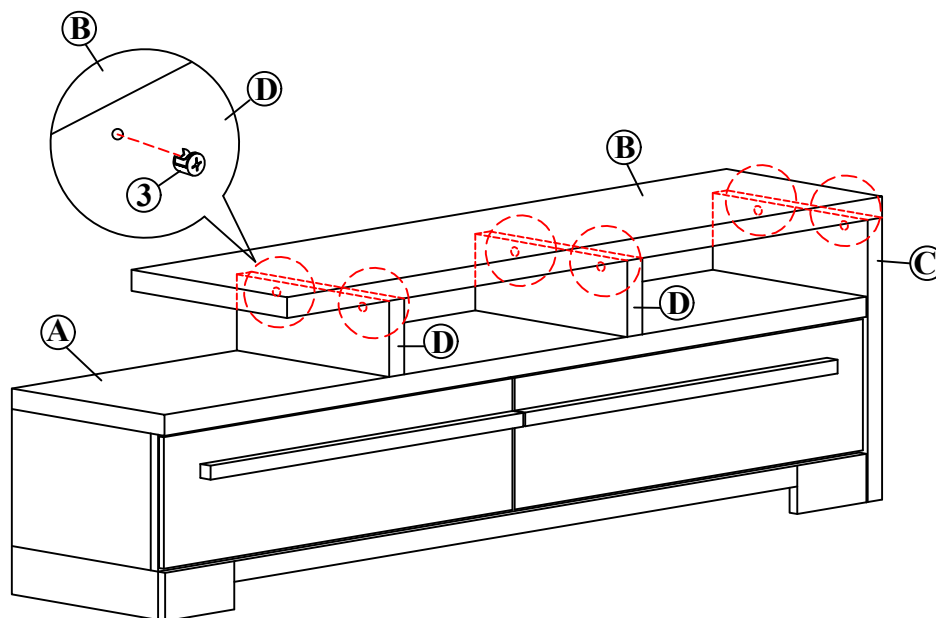

NOTE : ADJUST THE LEVELER ONLY IF IT IS BEING PLACED ON UNEVEN SURFACE.

THE HARDWARE IS LOCATED IN THE PACKING ITEMS

THE ANTI TIPPING HARDWARE IS LOCATED IN THE RIGHT SIDE FRONT DRAWER OF THE TV UNIT.

NOTE : MUST TIGHTEN SCREWS PERIODICALLY. WITH USE SCREW MAY BECOME LOOSE.  
CHECK TIGHTNESS OF ALL SCREW EVERY 6-8 WEEKS.

## CLEANING INSTRUCTION

After assembly, clean & polish the completed parts if necessary with soft cloth and industrial recognized furniture polish

MADE IN MALAYSIA