

# ASSEMBLY INSTRUCTION

ITEM NUMBER : B7300-Q-HB / B7300-Q-FB / B7300-KQ-RAIL

DESCRIPTION : QUEEN LED HEADBOARD / QUEEN FOOTBOARD / KING/QUEEN RAIL

Thank you for purchasing this quality product. Be sure to check all packing material carefully for small parts which may have loose inside the carton during shipment. Identify and count all parts and compare with the parts list below.





**(BOX 1)**

**BOX OF HEADBOARD & HEADBOARD POST**

NO	DRAWING	DESCRIPTION	QTY
A		Headboard	1pc

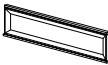

**(BOX 2)**

**BOX OF FOOTBOARD**

NO	DRAWING	DESCRIPTION	QTY
B		Footboard	1pc
C		Leg	2pcs
D		Slat	4pcs
E		Slat support leg	4pcs

**(BOX 2)**

**HARDWARE LIST**

NO	DRAWING	DESCRIPTION	QTY
1		Allen key	1pc
2		JCBC 35mm	4pcs
3		Screw 32mm	8pcs

**(BOX 3)**

**BOX OF SIDE RAIL**

NO	DRAWING	DESCRIPTION	QTY
F		Side Rail	2pcs

Remove Leg in the carton and unwrap each leg.

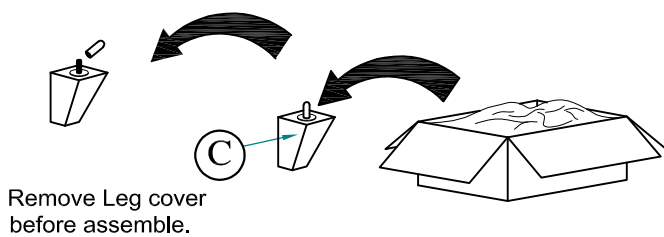

Step 1: Secure the (C) Leg to the bottom of (B) Footboard as a diagram shown.

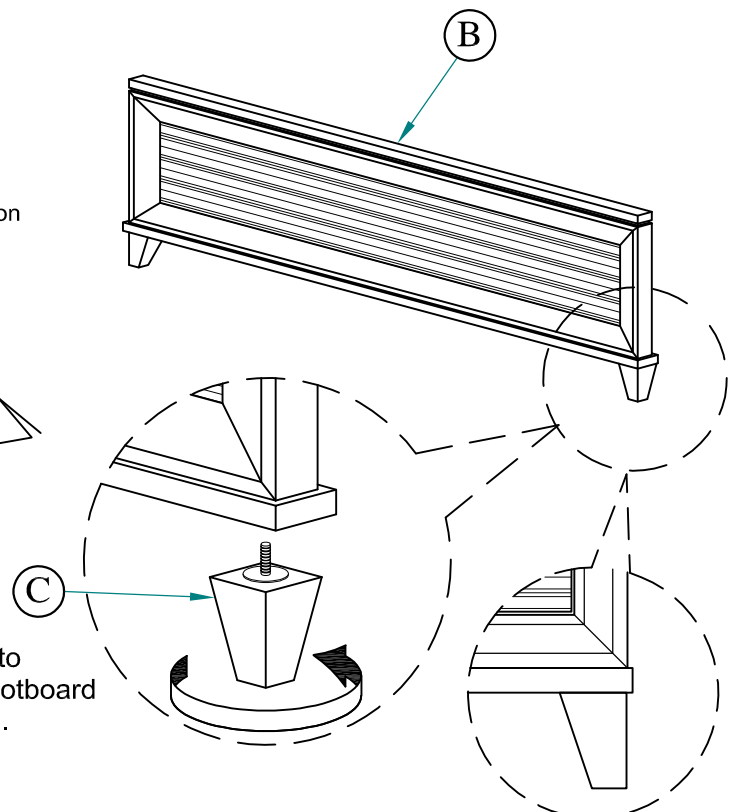

Ensure the bevel side of leg are facing to the center. Do not over turn.

**THE HARDWARE IS LOCATED IN THE PACKING ITEM**

NOTE : MUST TIGHTEN SCREW PERIODICALLY. WITH USE SCREW MAY BECOME LOOSE. CHECK TIGHTNESS OF ALL SCREW EVERY 6-8 WEEKS.

**CLEANING INSTRUCTION**

After assembly , clean & polish the completed parts if necessary with softcloth and industrial recognized furniture polish

Step 2: Attach the (F) Side Rail to the (A) Headboard & (B) Footboard.

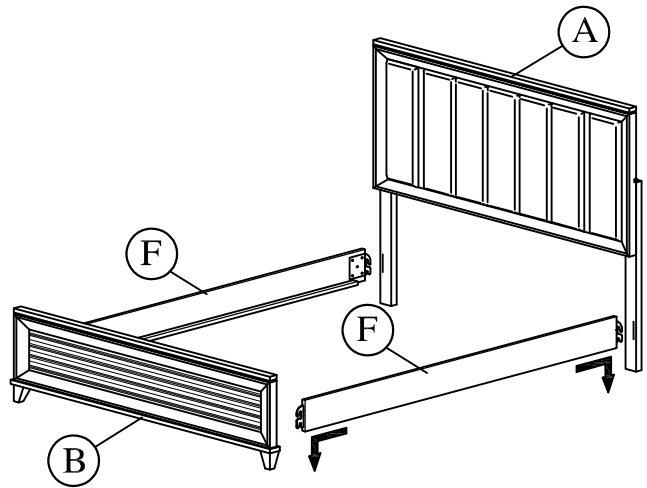

Step 3: Attach (E) Slat Support Leg to the bottom of (D) Slat using (2) JCBC 35mm and tighten the JCBC with (1) Allen key. Adjust the Adjustable Leveler to level the bed with the floor.

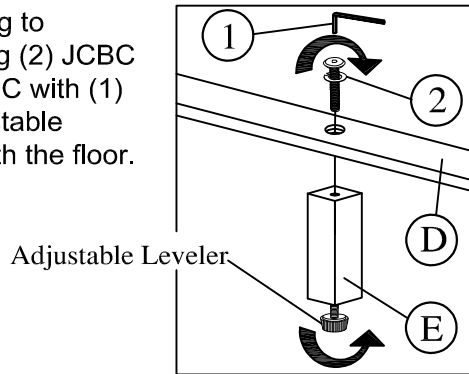

Step 4: Secure the (D) Slat using the (3) screw 32mm provided.

