





ASSEMBLY INSTRUCTIONS

B6840-Q-HBFB/B6840-KQ-POST





QUEEN HEADBOARD/FOOTBOARD/POST

CRWN

(BOX 1 & 2) - BOX OF QUEEN HEADBOARD AND FOOTBOARD

PARTS LIST				HARDWARE LIST			
NO.	DESCRIPTION	SKETCH	QTY	NO.	DESCRIPTION	SKETCH	QTY
1	HEADBOARD PANEL		1	A	JCBC (M6 x 35mm) W/FLAT WASHER & SPRING WASHER		12
2	FOOTBOARD PANEL		1	B	ALLEN KEY (M4)		1
				C	WOOD DOWEL (Ø8 x 30mm)		8

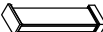
(BOX 2) - BOX OF QUEEN/KING POST

PARTS LIST			
NO.	DESCRIPTION	SKETCH	QTY
1	HEADBOARD POST LEFT		1
2	HEADBOARD POST RIGHT		1
3	FOOTBOARD POST LEFT		1
4	FOOTBOARD POST RIGHT		1

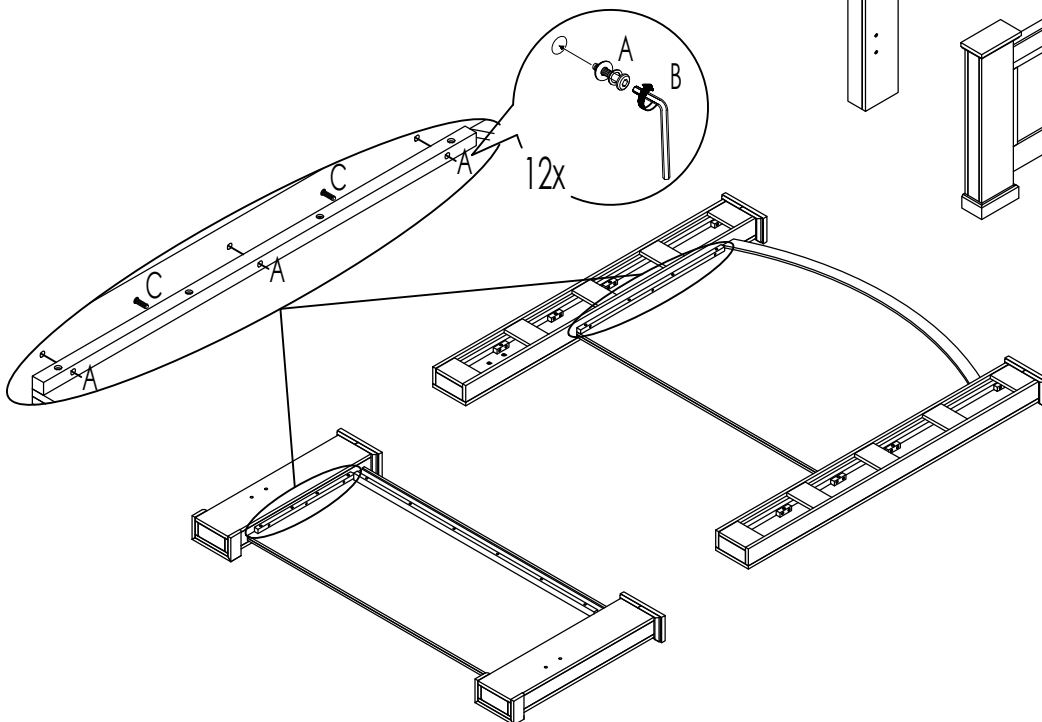
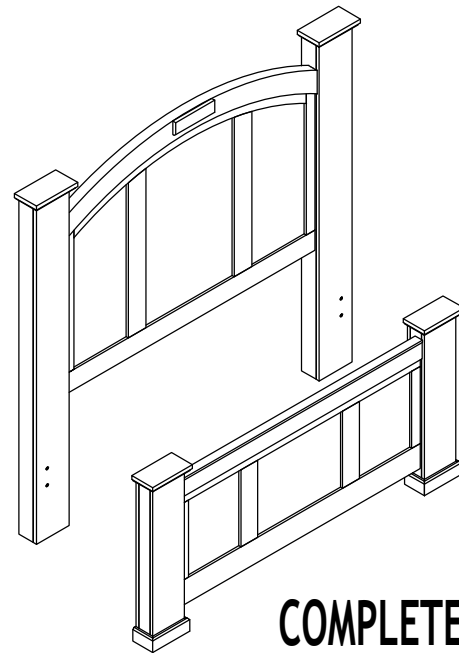

IMPORTANT NOTE :

- * Place all wooden parts on a clean and smooth surface such as a rug or carpet to avoid the parts from being scratched.
- * Check to be sure that you have all parts and hardware.
- * Remove all wrapping materials, including staples & packing straps before you start to assemble.
- * Do not tighten all screws/bolts until all completely assembled.
- * Keep all hardware parts out of reach of children.