

ASSEMBLY INSTRUCTIONS

B6800 / B6810-F-BED

CARTER FULL BED

CRWN

(BOX 1) - BOX OF FULL BED

PARTS LIST				HARDWARE LIST			
NO.	DESCRIPTION	SKETCH	QTY	NO.	DESCRIPTION	SKETCH	QTY
1	HEADBOARD PANEL		1	A	JCBC (M6 x 35mm) W/FLAT WASHER & SPRING WASHER		8
2	HEADBOARD LEG (L / R)		2	B	JCBB (M8 x 40mm) W/FLAT WASHER & SPRING WASHER		6
3	FOOTBOARD		1	C	JCBB (M8 x 20mm) W/FLAT WASHER		8
4	SIDE RAIL (L / R)		4	D	ALLEN KEY (M4)		1
5	CENTER LEG		2	E	ALLEN KEY (M5)		1
6	DECKING BOARD		4	F	PANHEAD SCREW (M4 x 32mm)		9
7	SLAT		4	G	PANHEAD SCREW (M3.5 x 20mm)		16
8	CENTER RAIL		1	H	SCREW DRIVER (*)		1
9	VERTICAL LEG		4	*The manufacturer does not provide item H.			

IMPORTANT NOTE :

- * Place all wooden parts on a clean and smooth surface such as a rug or carpet to avoid the parts from being scratched.
- * Check to be sure that you have all parts and hardware.
- * Remove all wrapping materials, including staples & packing straps before you start to assemble.
- * Do not tighten all screws/bolts until all completely assembled.
- * Keep all hardware parts out of reach of children.

STEP 4

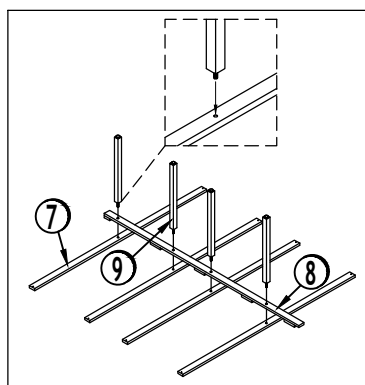

STEP 1

BACK VIEW

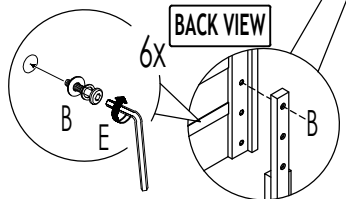

STEP 3

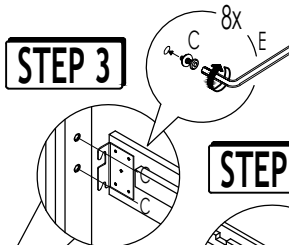

STEP 2

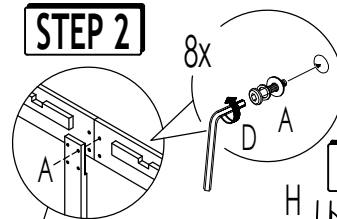

STEP 5

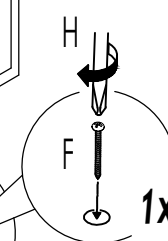
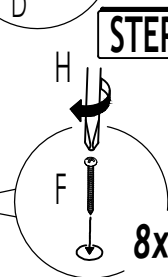

STEP 6

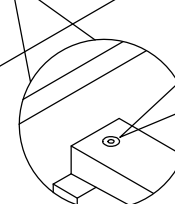





ASSEMBLY INSTRUCTIONS

B6800 / B6810-F-BED

CARTER FULL BED

CRWN

(BOX 2) - BOX OF LAMP			
HARDWARE LIST			
NO.	DESCRIPTION	SKETCH	QTY
I	LAMP		1
J	HEX NUT		2
K	FLAT WASHER		2
L	ALLEN WRENCH		1

STEP 8

BACK VIEW

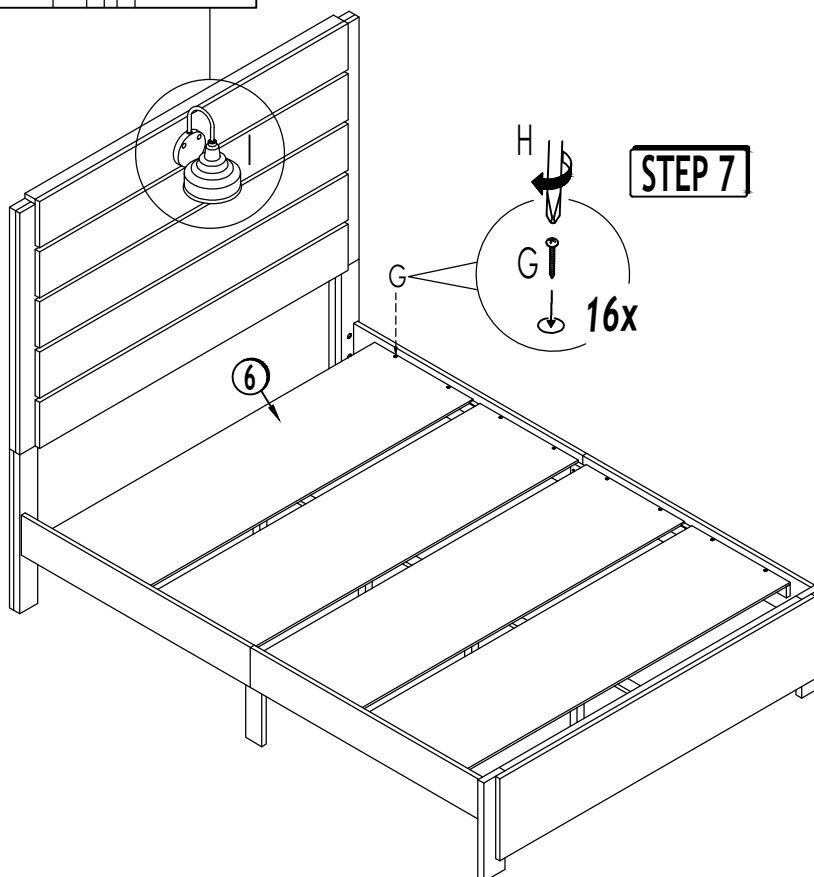
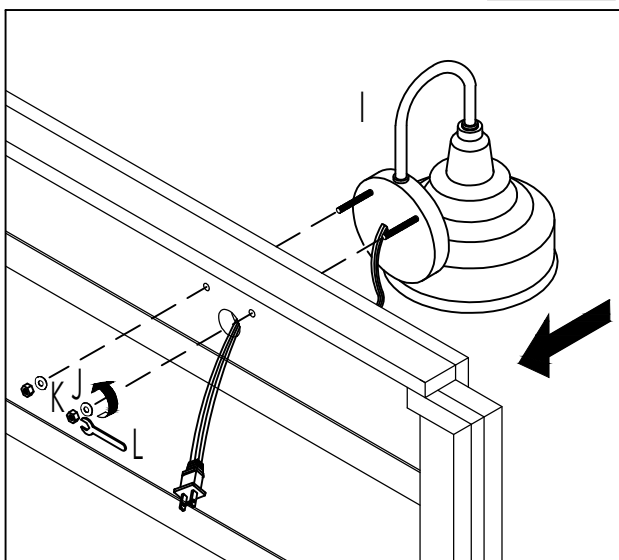

STEP 7

COMPLETE