







ASSEMBLY INSTRUCTION

MODEL NO: B6700-Q-HBFB & B6700-KQ-RAIL
FOR HEADBOARD, FOOTBOARD & SIDE RAIL

**(BOX 1)
BOX OF HEADBOARD & FOOTBOARD**

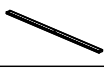
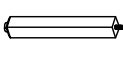
ITEM	DRAWING	DESCRIPTION	QTY
A		HEADBOARD PANEL	1
B		LEFT HEADBOARD LEG	1
C		RIGHT HEADBOARD LEG	1
D		FOOTBOARD	1
E		WOODEN SLAT	4
F		WOODEN SUPPORT	4

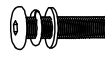
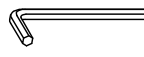
**(BOX 1)
HARDWARE LIST**

ITEM	DRAWING	DESCRIPTION	QTY
1		JCBC M8 x 35mm With Spring Washer With Flat Washer	6
2		ALLEN KEY (M5)	1
3		CSK SCREW (M4 x 32mm)	8
4		SCREW DRIVER (*)	1

The manufacturer does not provide item 4.

**(BOX 2)
BOX OF SIDE RAIL**

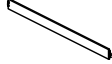
ITEM	DRAWING	DESCRIPTION	QTY
G		SIDE RAIL	2

Step 1

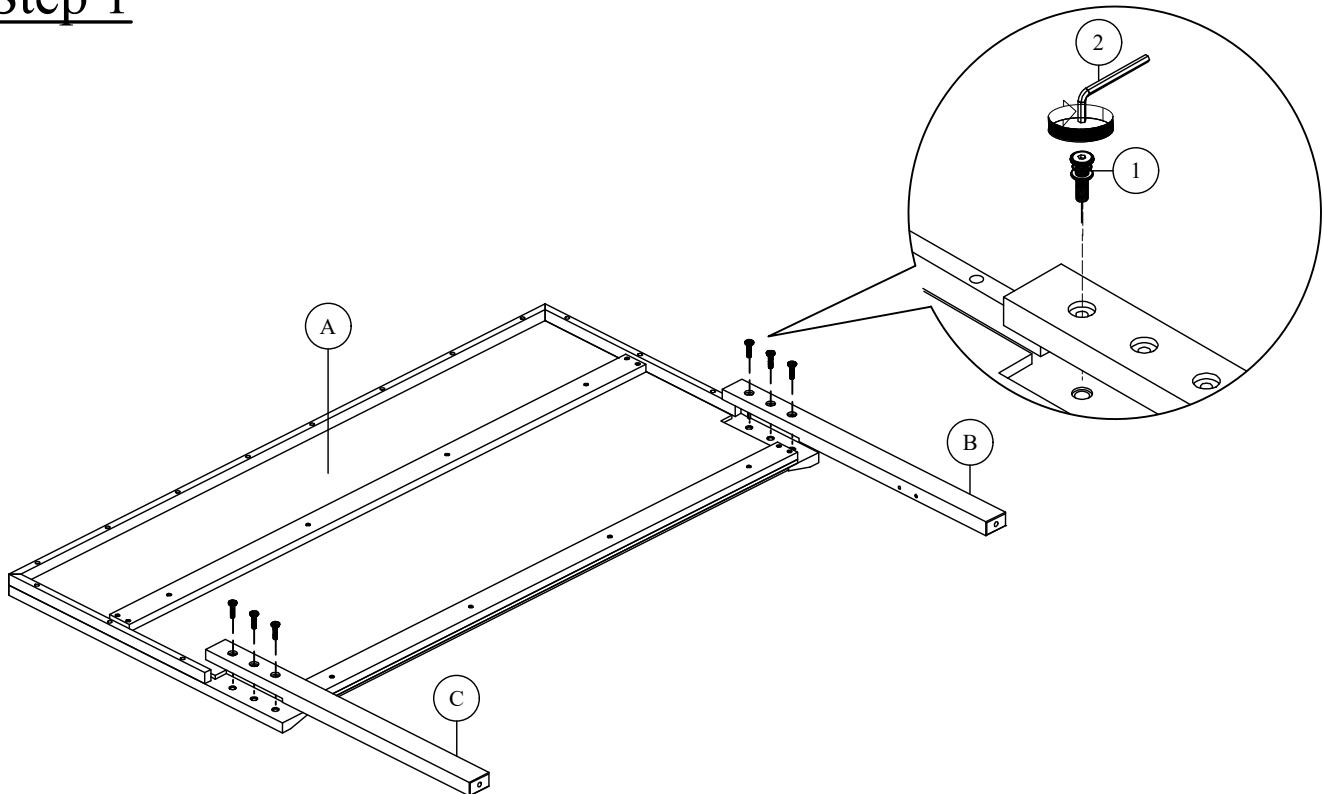

THE HARDWARE IS LOCATED IN THE PACKING ITEMS

NOTE : MUST TIGHTEN SCREWS PERIODICALLY. WITH USE SCREWS MAY LOOSE.
CHECK TIGHNESS OF ALL SCREWS VERY 6-8 WEEKS.

CLEANING INSTRUCTION

After assembled, clean & polish the completed parts if necessary with soft cloth and industrial recognized furniture polish

MADE IN MALAYSIA

QUEEN BED K/D

ASSEMBLY INSTRUCTION

MODEL NO: B6700-Q-HBFB & B6700-KQ-RAIL
FOR HEADBOARD, FOOTBOARD & SIDE RAIL

Step 2

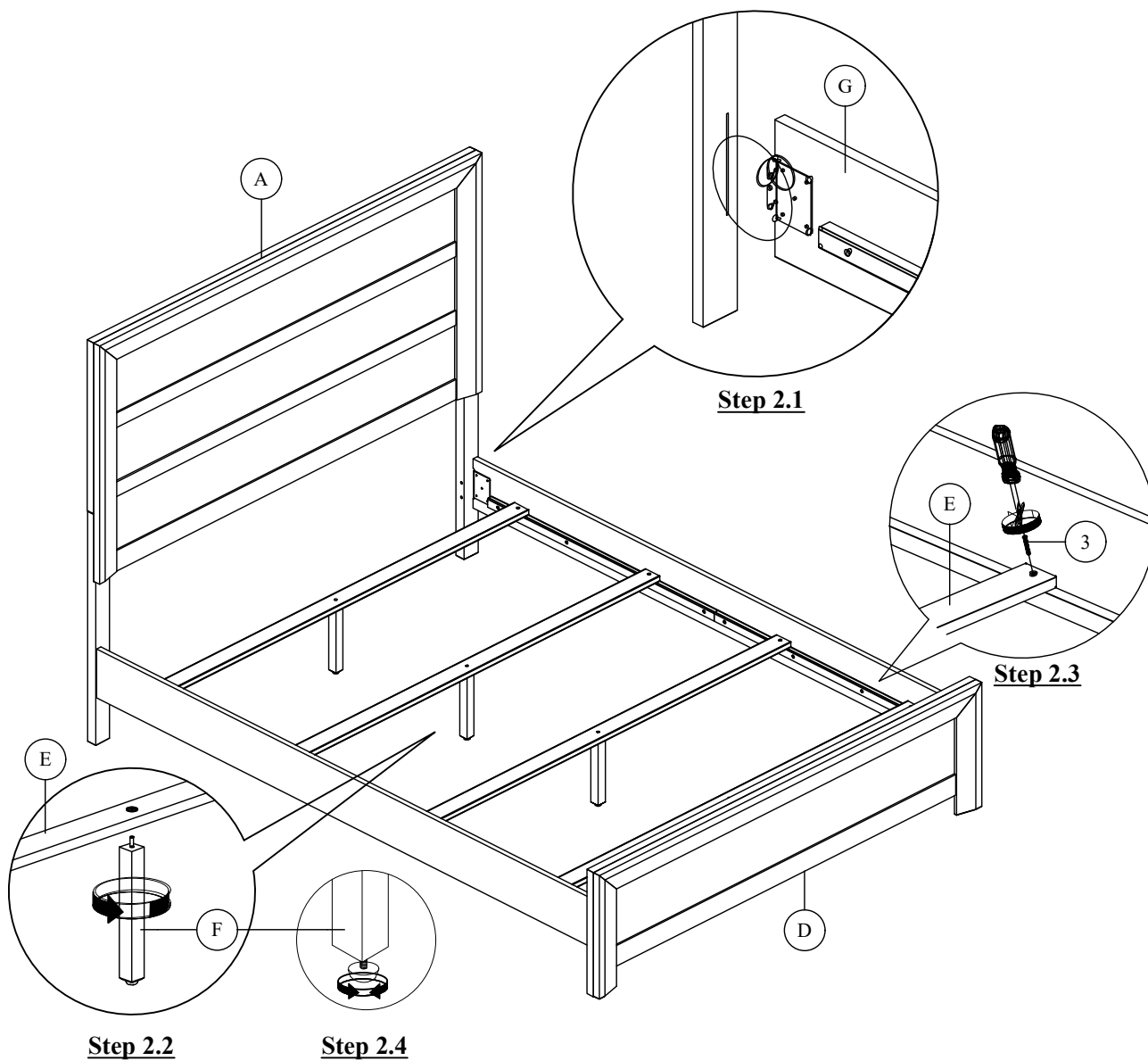

THE HARDWARE IS LOCATED IN THE PACKING ITEMS

NOTE : MUST TIGHTEN SCREWS PERIODICALLY. WITH USE SCREWS MAY LOOSE.
CHECK TIGHTNESS OF ALL SCREWS VERY 6-8 WEEKS.

CLEANING INSTRUCTION

After assembled, clean & polish the completed parts if necessary with soft cloth and industrial recognized furniture polish

MADE IN MALAYSIA

QUEEN BED K/D