

# ASSEMBLY INSTRUCTIONS



## CROWN MARK (CRWN)

MODEL: B6580-Q-HB / B6580-K-HB (Queen Headboard / King Headboard)

Thank you for purchasing this quality product. Be sure to check all packing material carefully for small parts which may have come loose inside the carton during shipment. Identify and count all parts and compare with hardware list as below:

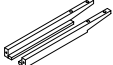
### STEP 1

(BOX 1) BOX OF HEADBOARD			
ITEM	DRAWING	DESCRIPTION	QTY
A		HEAD BOARD	1
B		HB LEG POST (L/R)	2

(BOX 1) BOX OF HEADBOARD (HARDWARE LIST)				
ITEM	DRAWING	DESCRIPTION	DIMENSION	QTY
C		JCBC (M8) WITH WASHER	8 x P1.25 x 50MM	4
D		ALLEN KEY M5	5 x 120MM	1

THE HARDWARE IS LOCATED IN THE PACKING ITEMS

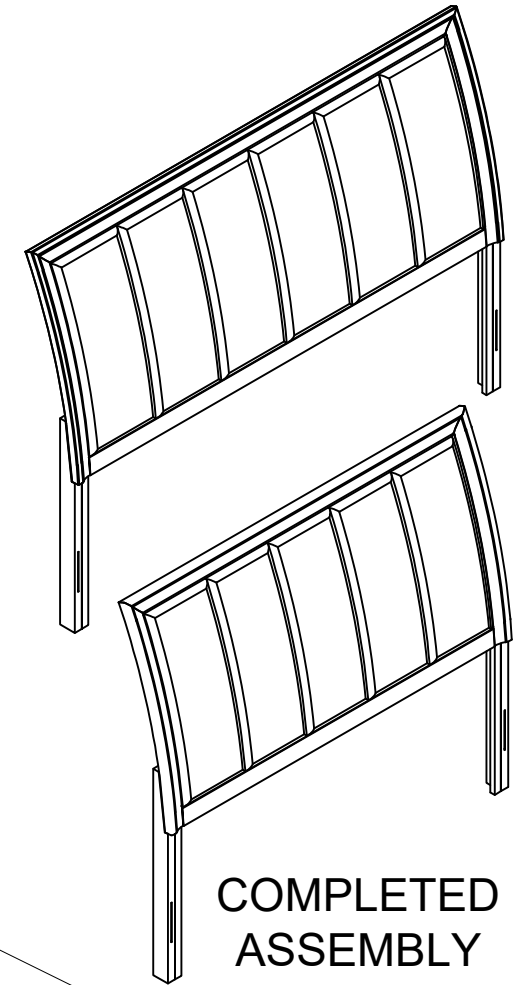
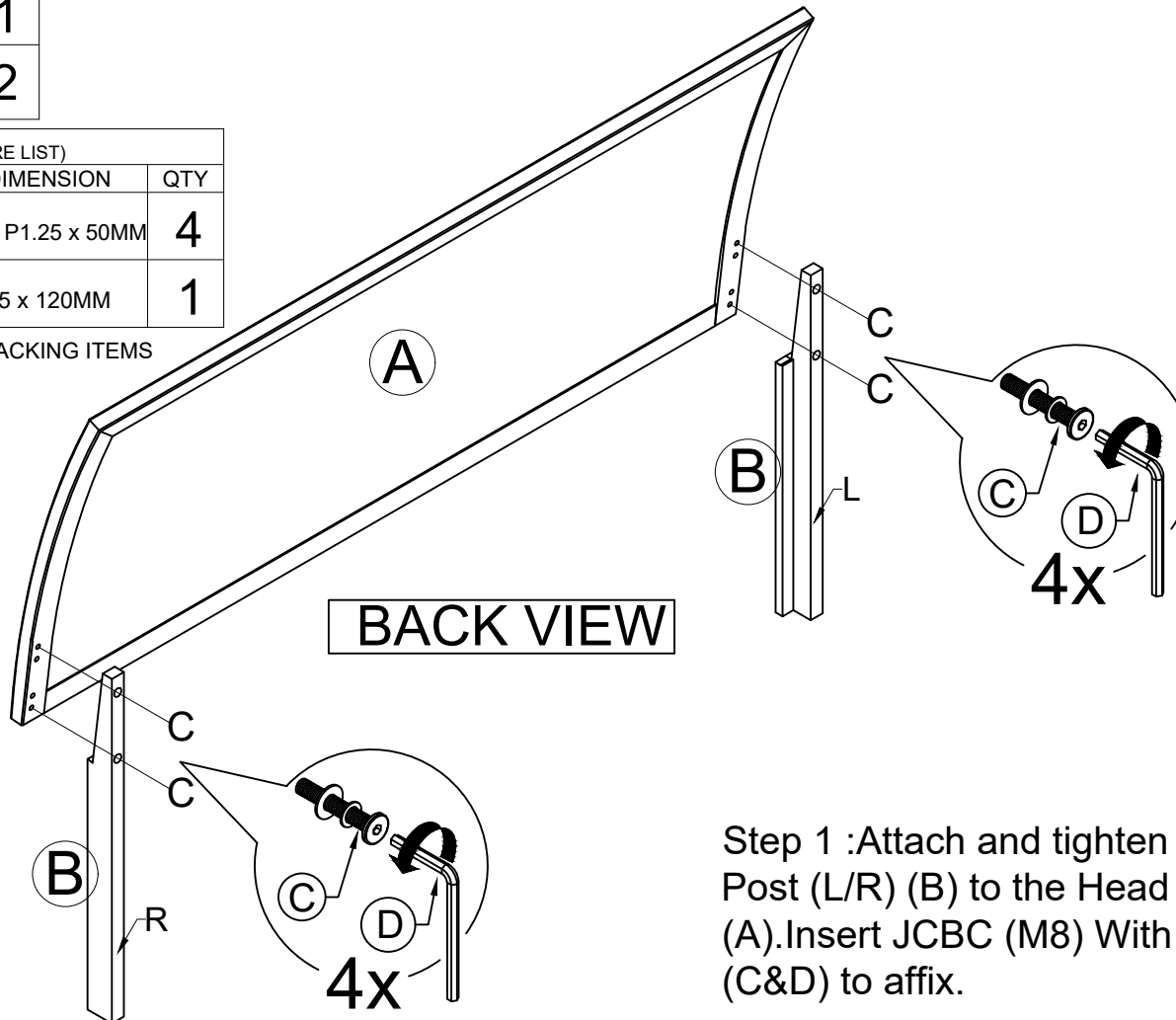

Step 1 : Attach and tighten the Leg Post (L/R) (B) to the Head Board (A). Insert JCBC (M8) With Washer (C&D) to affix.

NOTE: MUST TIGHTEN SCREW PERIODICALLY. WITH USE SCREWS WILL BECOME LOOSE CHECK TIGHT OF ALL SREWS EVERY 6-8 WEEKS.

#### CLEANING INSTRUCTION

After assembled, clean & polish the complete parts if necessary with soft cloth and industrial recognized furniture polish.

MADE IN MALAYSIA

# ASSEMBLY INSTRUCTIONS

## CROWN MARK (CRWN)

MODEL: B6580-K-HB, B6580-K-FBD, B6580-KQ-RAIL (King Storage Bed)

Thank you for purchasing this quality product. Be sure to check all packing material carefully for small parts which may have come loose inside the carton during shipment. Identify and count all parts and compare with hardware list as below:

### STEP 1

(BOX 1) BOX OF HEAD BOARD				
ITEM	DRAWING	DESCRIPTION	QTY	
A		HEAD BOARD	1	

(BOX 2) BOX OF FOOT BOARD				
ITEM	DRAWING	DESCRIPTION	QTY	
B		FOOT BOARD	1	
C		FB LEG	2	

D		LEG SUPPORT FOR FB	2	
E		WOODEN PANEL	6	
F		WOODEN SLAT	4	
G		SLATS SUPPORT	8	

(BOX 3) BOX OF SIDE RAILS				
ITEM	DRAWING	DESCRIPTION	QTY	
H		SIDE RAIL (L&R)	2	

(BOX 2) BOX OF FOOT BOARD (HARDWARE LIST)				
ITEM	DRAWING	DESCRIPTION	DIMENSION	QTY
I		C.S.K SCREW (M4)	4 X 32MM	8
J		C.S.K SCREW (M3.5)	3.5 x 20MM	24
K		JCBC (M6) WITH WASHER	6 x P1.0 x 100MM	2
L		ALLEN KEY M4	4 x 65MM	1

--	--	--	--	--

--	--	--	--	--

--	--	--	--	--

--	--	--	--	--

--	--	--	--	--

--	--	--	--	--

--	--	--	--	--

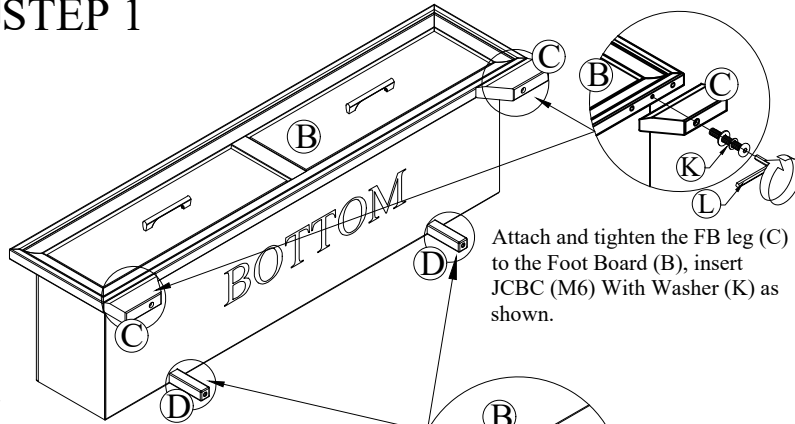

Attach and tighten the FB leg (C) to the Foot Board (B), insert JCBC (M6) With Washer (K) as shown.

Affix the Leg Support (D) to Foot Board (B) as shown. Loosen or tighten Leg Support (D) as necessary to level the bed.

### STEP 2

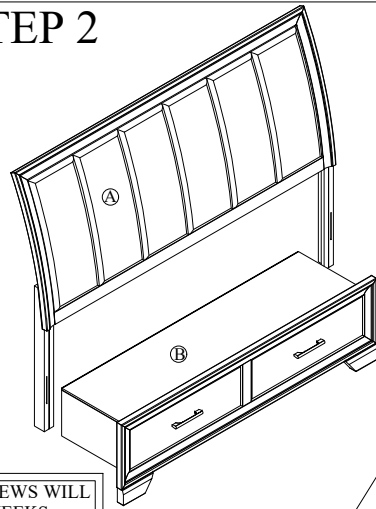

### STEP 4

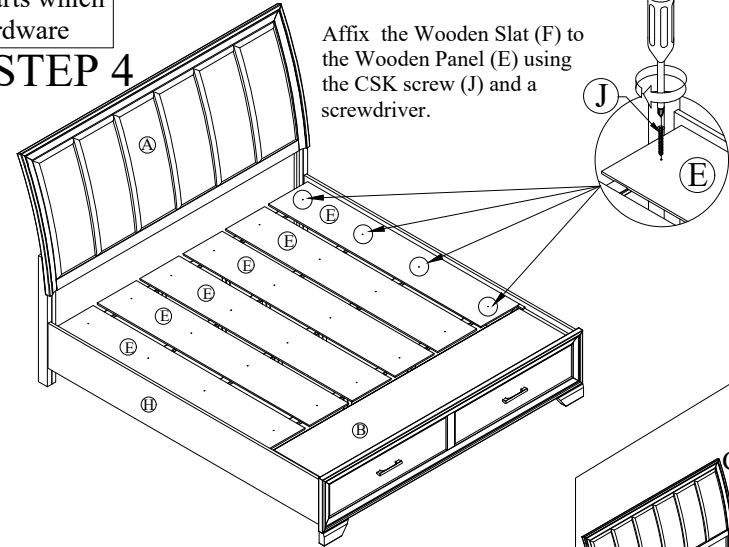

Affix the Wooden Slat (F) to the Wooden Panel (E) using the CSK screw (J) and a screwdriver.

### STEP 3

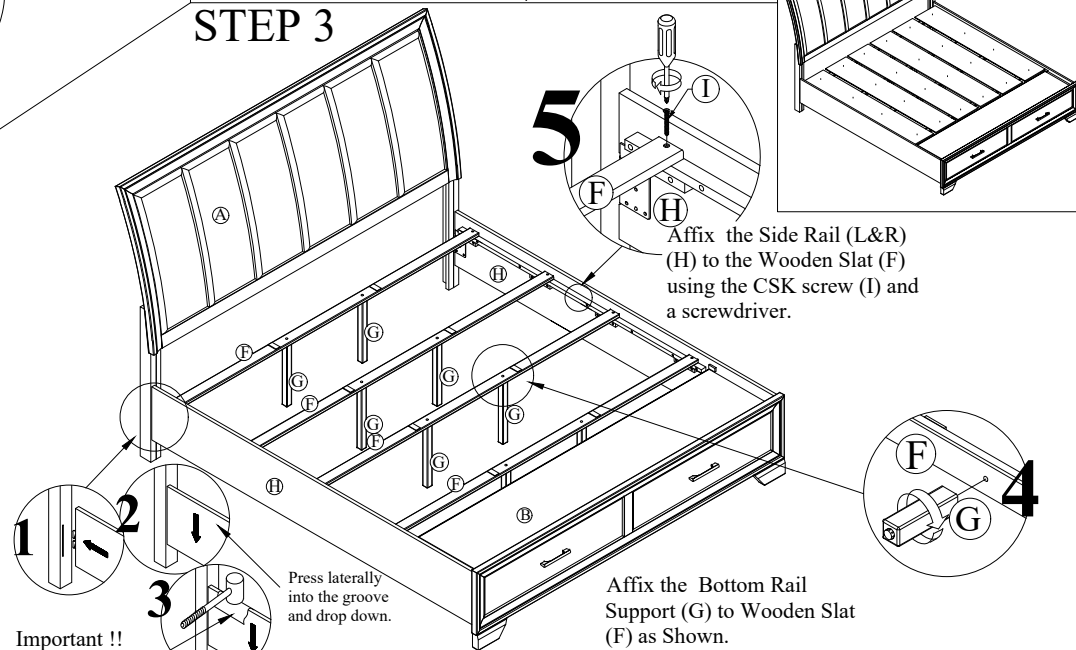

Affix the Side Rail (L&R) (H) to the Wooden Slat (F) using the CSK screw (I) and a screwdriver.

**Important !!**  
LEVEL THE SIDE RAIL BY COVERING WITH A SOFT CLOTH AND TAPPING WITH A HAMMER.

Press laterally into the groove and drop down.

Affix the Bottom Rail Support (G) to Wooden Slat (F) as Shown.

COMPLETED ASSEMBLY

MADE IN MALAYSIA

NOTE: MUST TIGHTEN SCREW PERIODICALLY. WITH USE SCREWS WILL BECOME LOOSE CHECK TIGHT OF ALL SREWS EVERY 6-8 WEEKS.

#### CLEANING INSTRUCTION

After assembled, clean & polish the complete parts if necessary with soft cloth and industrial recognized furniture polish.