



# ASSEMBLY INSTRUCTIONS



CROWN MARK (CRWN)

MODEL:B6560-1 DRESSER

THANK YOU FOR PURCHASING THIS QUALITY PRODUCT.BE SURE TO CHECK ALL PACKING MATERIAL CAREFULLY FOR SMALL PARTS WHICH MAY HAVE COME LOOSE INSIDE THE CARTON DURING SHIPMENT.IDENTIFY AND COUNT ALL PARTS AND COMPARE WITH HARDWARE LIST AS BELOW :

(BOX 1) BOX OF DRESSER			
ITEM	DRAWING	DESCRIPTION	QTY
A		DRESSER	1
B		BOTTOM LEG	4
C		SUPPORT LEG	1

STEP 1 :ATTACH AND TIGHTEN THE DRESSER BOTTOM LEG (B) TO THE BOTTOM FRAME AND INSERT CONNECTION BOLT (E) WITH WASHER AS SHOWN.

(BOX 1) BOX OF DRESSER (HARDWARE LIST)				
ITEM	DRAWING	DESCRIPTION	DIMENSION	QTY
D		ALLEN KEY M4	M4x55MM	1
E		CONNECTION BOLT (M6x100mm) W/SPRING WASHER & WASHER MEDIUM		4
F		ANTI TIPPING RESTRAINT (Located in Dresser 1st RSF Drawer)		1

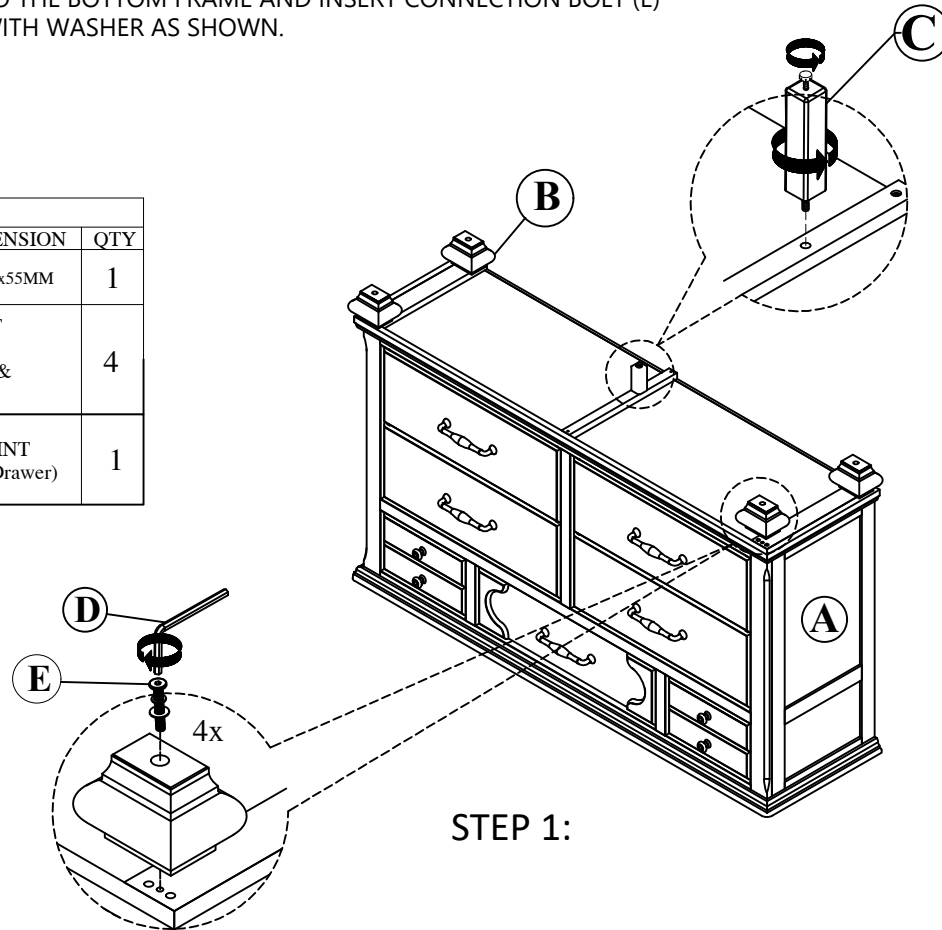

STEP 1:

STEP 2 : Move the Dresser (A) into final position and use tipping restraint (F) attach to wall

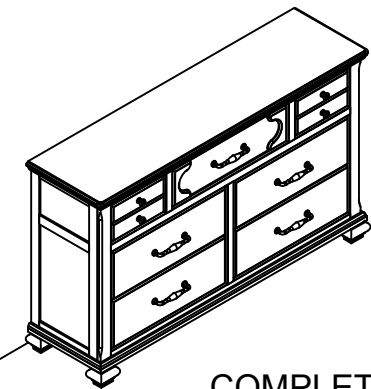
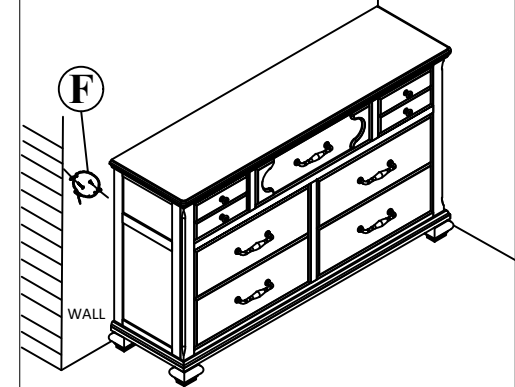

COMPLETED ASSEMBLY

MADE IN MALAYSIA

NOTE:MUST TIGHTEN SCREW PERIODICALLY.WITH USE SCREWS WILL BECOME LOOSE CHECK THIGHT OF ALL SREWS EVERY 6-8 WEEKS.  
CLEANING INSTRUCTION  
After assembled,clean & polish the complete parts if necessary with soft clotch ang industrial recognized furniture polish.

THE ANTI TIPPING HARDWARE IS LOCATED IN THE 1ST RIGHT SIDE FRONT DRAWER OF DRESSER

THE HARDWARE IS LOCATED IN THE PACKING ITEMS