





ASSEMBLY INSTRUCTIONS

CROWN MARK (CRWN)

MODEL: B6540-Q-HB QUEEN HEAD BOARD / B6540-K-HB KING HEAD BOARD

THANK YOU FOR PURCHASING THIS QUALITY PRODUCT. BE SURE TO CHECK ALL PACKING MATERIAL CAREFULLY FOR SMALL PARTS WHICH MAY HAVE COME LOOSE INSIDE THE CARTON DURING SHIPMENT. IDENTIFY AND COUNT ALL PARTS AND COMPARE WITH HARDWARE LIST AS BELOW:

(BOX 1) BOX OF HEADBOARD			
ITEM	DRAWING	DESCRIPTION	QTY
A		HEAD BOARD	1
B		HB LEG POST (L/R)	2

(BOX 1) BOX OF HEADBOARD (HARDWARE LIST)				
ITEM	DRAWING	DESCRIPTION	DIMENSION	QTY
C		ALLEN KEY M4	5 X 35 X 120MM	1
D		CONNECTION BOLT (M8x35mm) W/SPRING WASHER & WASHER MEDIUM		6

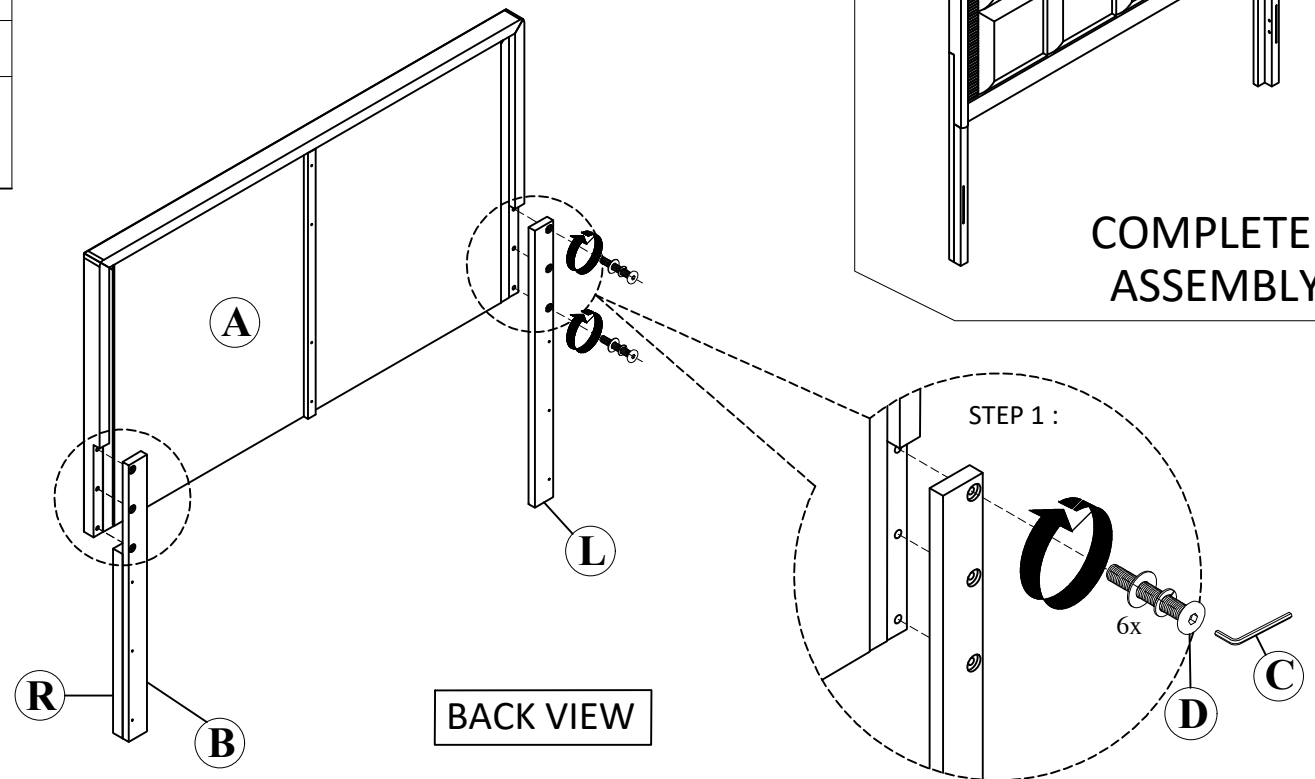
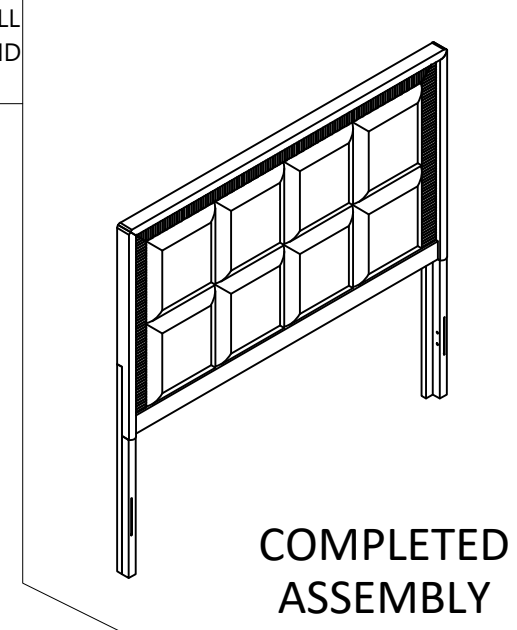

STEP 1 : ATTACH AND TIGHTEN THE LEG POST (L/R) (B) TO THE HEADBOARD (A). INSERT CONNECTION BOLT (D) WITH WASHER TO AFFIX.

NOTE: MUST TIGHTEN SCREW PERIODICALLY. WITH USE SCREW WILL BECOME LOOSE CHECK TIGHT OF ALL SCREWS EVERY 6-8 WEEKS.

CLEANING INSTRUCTION
AFTER ASSEMBLED, CLEAN & POLISH THE COMPLETE PARTS IF NECESSARY WITH SOFT CLOTH AND INDUSTRIAL RECOGNIZED FURNITURE POLISH.

THE HARDWARE IS LOCATED IN THE PACKING ITEMS

MADE IN MALAYSIA