

ASSEMBLY INSTRUCTIONS

CROWN MARK (CRWN)

MODEL: B6540-K-FB & B6540-KQ-RAIL KING BED

THANK YOU FOR PURCHASING THIS QUALITY PRODUCT. BE SURE TO CHECK ALL PACKING MATERIAL CAREFULLY FOR SMALL PARTS WHICH MAY HAVE COME LOOSE INSIDE THE CARTON DURING SHIPMENT. IDENTIFY AND COUNT ALL PARTS AND COMPARE WITH HARDWARE LIST AS BELOW:

PART LIST

(BOX 1) BOX OF HEADBOARD

ITEM	DRAWING	DESCRIPTION	QTY
A		HEADBOARD	1

(BOX 2) BOX OF FOOTBOARD

ITEM	DRAWING	DESCRIPTION	QTY
B		FOOTBOARD	1

ITEM	DRAWING	DESCRIPTION	QTY
C		WOODEN SLAT	4

ITEM	DRAWING	DESCRIPTION	QTY
D		SLATS SUPPORT	8

(BOX 2) BOX OF FOOTBOARD HARDWARE LIST

ITEM	DRAWING	DESCRIPTION	DIMENSION	QTY
E		C.S.K. SCREW(M4)	4 X 32MM	8

(BOX 3) BOX OF SIDE RAILS

ITEM	DRAWING	DESCRIPTION	QTY
F		SIDE RAILS	2

SCREW DRIVER IS NOT INCLUDED



HAMMER IS NOT INCLUDED

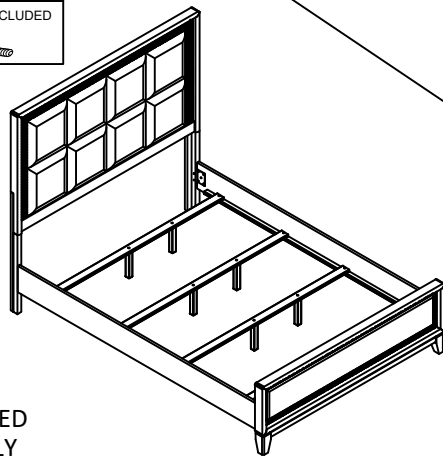
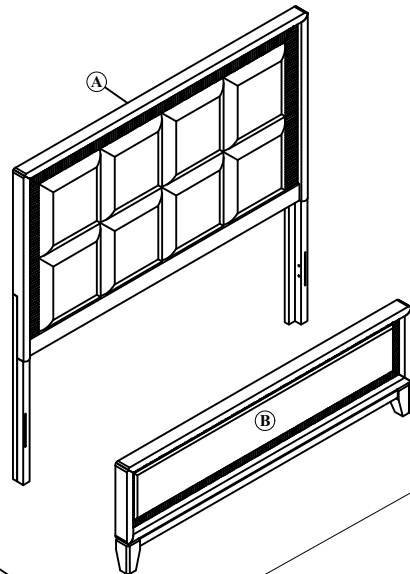

COMPLETED ASSEMBLY

NOTE: MUST TIGHTEN SCREW PERIODICALLY. WITH USE SCREW WILL BECOME LOOSE CHECK TIGHT OF ALL SCREWS EVERY 6-8 WEEKS.

CLEANING INSTRUCTION
AFTER ASSEMBLED, CLEAN & POLISH THE COMPLETE PARTS IF NECESSARY WITH SOFT CLOTH AND INDUSTRIAL RECOGNIZED FURNITURE POLISH.

STEP 5 :

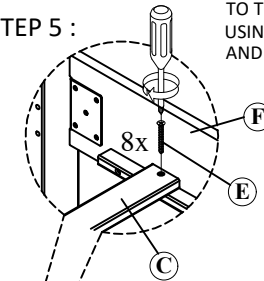

AFFIX THE SIDE RAIL (F) TO THE WOODEN SLAT (C) USING THE CSK SCREW (E) AND A SCREWDRIVER.

STEP 4 :

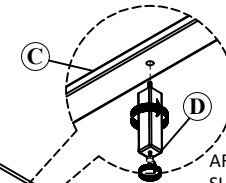

AFFIX THE SLAT SUPPORT (D) AND ADJUST HEIGHT FOR THE WOODEN SLAT (C)

STEP 1 :

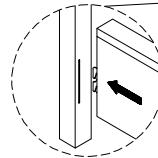

STEP 2 :

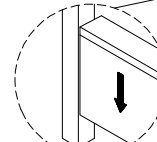

PRESS LATERALLY INTO THE GROOVE AND DROP DOWN.

STEP 3 :

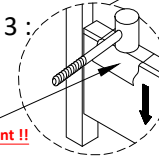

Important !!

LEVEL THE SIDE RAIL BY COVERING WITH A SOFT CLOTH AND TAPPING WITH A HAMMER.

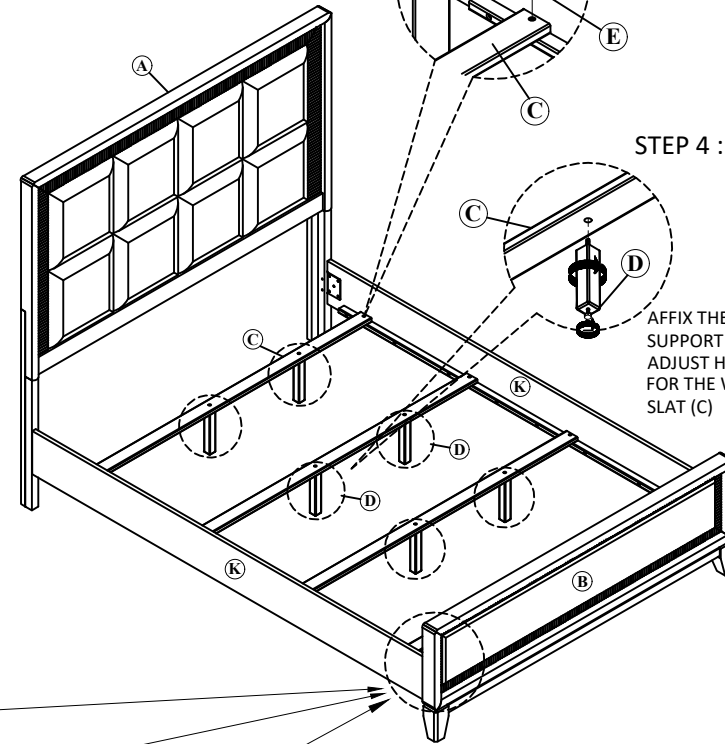

THE HARDWARE IS LOCATED IN THE PACKING ITEMS

MADE IN MALAYSIA