



ASSEMBLY INSTRUCTIONS



CROWN MARK (CRWN)

MODEL:B6540-4 CHEST

THANK YOU FOR PURCHASING THIS QUALITY PRODUCT.BE SURE TO CHECK ALL PACKING MATERIAL CAREFULLY FOR SMALL PARTS WHICH MAY HAVE COME LOOSE INSIDE THE CARTON DURING SHIPMENT.IDENTIFY AND COUNT ALL PARTS AND COMPARE WITH HARDWARE LIST AS BELOW:

(BOX 1) BOX OF CHEST			
ITEM	DRAWING	DESCRIPTION	QTY
A		CHEST	1
B		BOTTOM LEG	4

STEP 1 :ATTACH AND TIGHTEN THE CHEST BOTTOM LEG (B) TO THE BOTTOM FRAME AND INSERT CONNECTION BOLT (D) WITH WASHER AS SHOWN.

(BOX 1) BOX OF CHEST (HARDWARE LIST)				
ITEM	DRAWING	DESCRIPTION	DIMENSION	QTY
C		ALLEN KEY M4	M4x55MM	1
D		CONNECTION BOLT (M6x60mm) W/SPRING WASHER & WASHER MEDIUM		4
E		ANTI TIPPING RESTRAINT (LOCATED IN THE CHEST 1ST DRAWER)		1

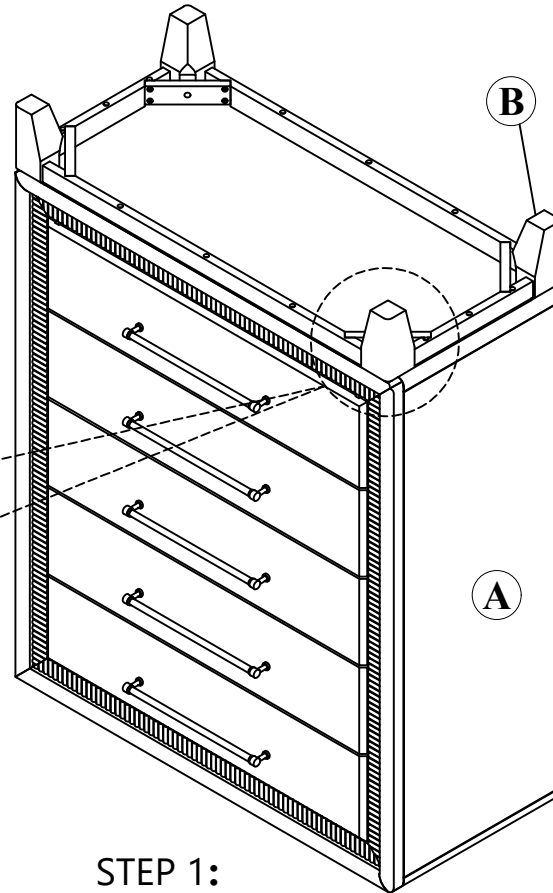
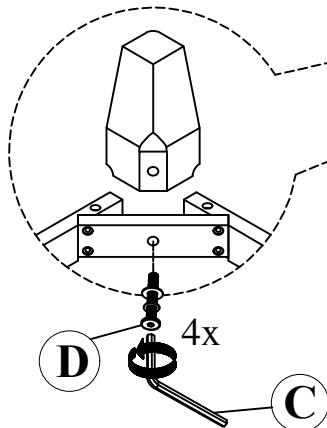

STEP 1:

STEP 2 : Move the Chest (A) into final position and use tipping restraint (E) attach to wall

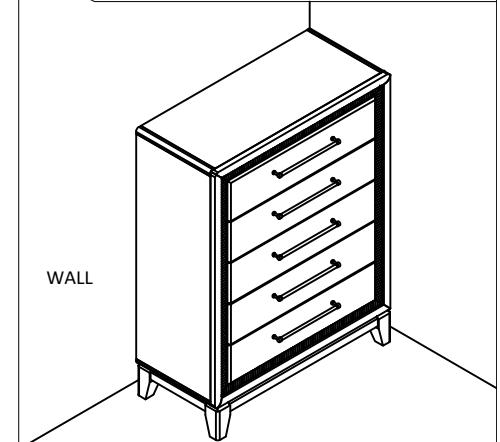
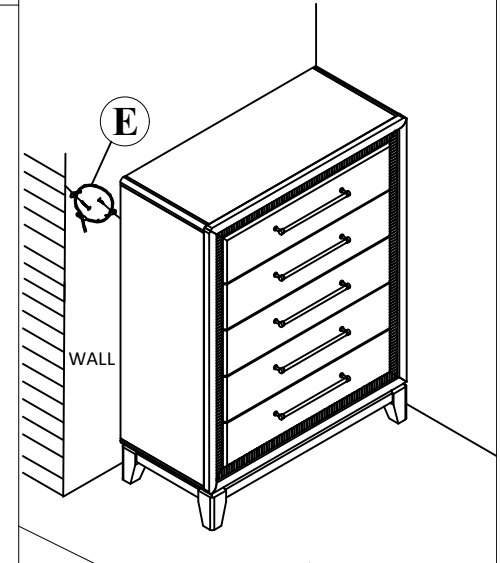

COMPLETED ASSEMBLY

MADE IN MALAYSIA

NOTE:MUST TIGHTEN SCREW PERIODICALLY.WITH USE SCREWS WILL BECOME LOOSE CHECK THIGHT OF ALL SREWS EVERY 6-8 WEEKS.

CLEANING INSTRUCTION

After assembled, clean & polish the complete parts if necessary with soft cloth ang industrial recognized furniture polish.

THE ANTI TIPPING HARDWARE IS LOCATED IN THE CHEST FIRST DRAWER
THE HARDWARE IS LOCATED IN THE PACKING ITEMS