

ASSEMBLY INSTRUCTIONS

CROWN MARK (CRWN)



MODEL:B6540-1 DRESSER & B6540-11 DRESSER TOP

THANK YOU FOR PURCHASING THIS QUALITY PRODUCT. BE SURE TO CHECK ALL PACKING MATERIAL CAREFULLY FOR SMALL PARTS WHICH MAY HAVE COME LOOSE INSIDE THE CARTON DURING SHIPMENT. IDENTIFY AND COUNT ALL PARTS AND COMPARE WITH HARDWARE LIST AS BELOW:



STEP 2 : Move the Dresser Top (A) & Mirror (B) into final position and use tipping restraint (D) attach to wall

(BOX 1) BOX OF DRESSER			
ITEM	DRAWING	DESCRIPTION	QTY
A		DRESSER	1

STEP 1 : ATTACH AND TIGHTEN THE MIRROR SUPPORT (C) TO THE DRESSER (A) AND MIRROR FRAME (B) AT BACK, INSERT CONNECTION BOLT (F) WITH WASHER AS SHOWN.

(BOX 2) BOX OF MIRROR			
ITEM	DRAWING	DESCRIPTION	QTY
B		MIRROR	1
C		MIRROR SUPPORT (L&R)	2

(BOX 1) BOX OF DRESSER (HARDWARE LIST)			
ITEM	DRAWING	DESCRIPTION	QTY
D		ANTI TIPPING RESTRAINT (Located in Dresser 1st RSF Drawer)	1

(BOX 2) BOX OF MIRROR (HARDWARE LIST)				
ITEM	DRAWING	DESCRIPTION	DIMENSION	QTY
E		ALLEN KEY M4	M4x55MM	1
F		CONNECTION BOLT (M6x60mm) W/SPRING WASHER & WASHER MEDIUM		10

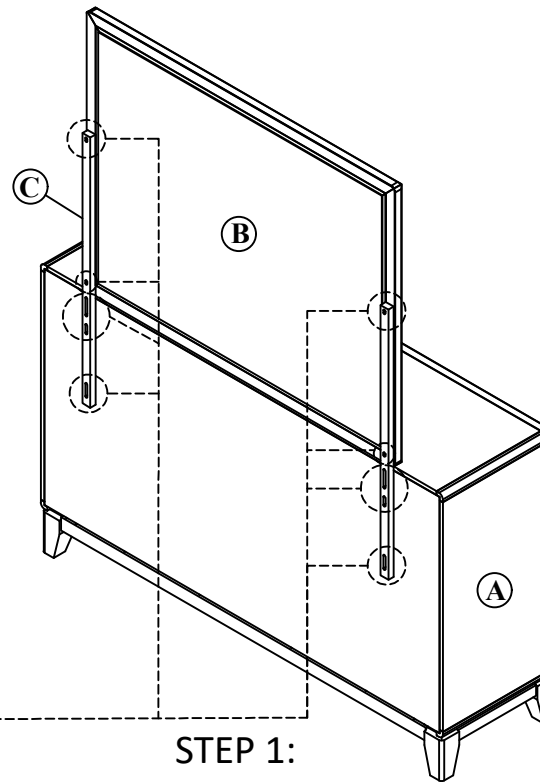

STEP 1:

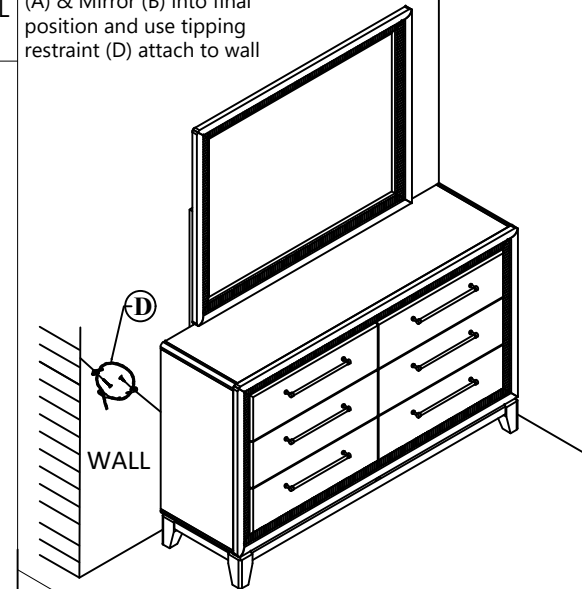
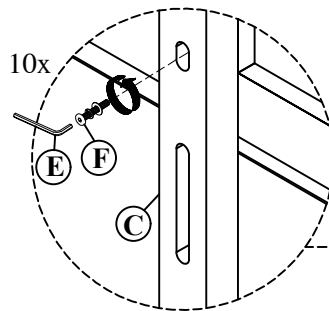

WALL

WALL

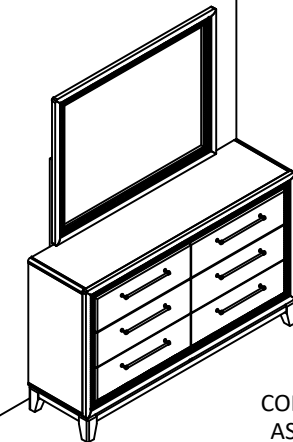

COMPLETED ASSEMBLY

MADE IN MALAYSIA

NOTE: MUST TIGHTEN SCREW PERIODICALLY. WITH USE SCREW WILL BECOME LOOSE. CHECK TIGHT OF ALL SCREWS EVERY 6-8 WEEKS.

CLEANING INSTRUCTION
AFTER ASSEMBLED, CLEAN & POLISH THE COMPLETE PARTS IF NECESSARY WITH SOFT CLOTH AND INDUSTRIAL RECOGNIZED FURNITURE POLISH.

THE ANTI TIPPING HARDWARE IS LOCATED IN THE 1ST RIGHT SIDE FRONT DRAWER OF DRESSER

THE HARDWARE IS LOCATED IN THE PACKING ITEMS