



ASSEMBLY INSTRUCTIONS



CROWN MARK (CRWN)

MODEL: B6540-1 DRESSER

THANK YOU FOR PURCHASING THIS QUALITY PRODUCT. BE SURE TO CHECK ALL PACKING MATERIAL CAREFULLY FOR SMALL PARTS WHICH MAY HAVE COME LOOSE INSIDE THE CARTON DURING SHIPMENT. IDENTIFY AND COUNT ALL PARTS AND COMPARE WITH HARDWARE LIST AS BELOW:

| (BOX 1) BOX OF DRESSER | | | |
|------------------------|---|-------------|-----|
| ITEM | DRAWING | DESCRIPTION | QTY |
| A |  | DRESSER | 1 |
| B |  | BOTTOM LEG | 4 |
| C |  | SUPPORT LEG | 1 |

STEP 1 : ATTACH AND TIGHTEN THE DRESSER BOTTOM LEG (B) TO THE BOTTOM FRAME AND INSERT CONNECTION BOLT (E) WITH WASHER AS SHOWN.

| (BOX 1) BOX OF DRESSER (HARDWARE LIST) | | | | |
|--|---|---|-----------|-----|
| ITEM | DRAWING | DESCRIPTION | DIMENSION | QTY |
| D |  | ALLEN KEY M4 | M4 X 55MM | 1 |
| E |  | CONNECTION BOLT (M6x60mm) W/SPRING WASHER & WASHER MEDIUM | | 4 |
| F |  | TIPPING RESTRAINT (LOCATED IN THE 1st RSF DRAWER) | | 1 |

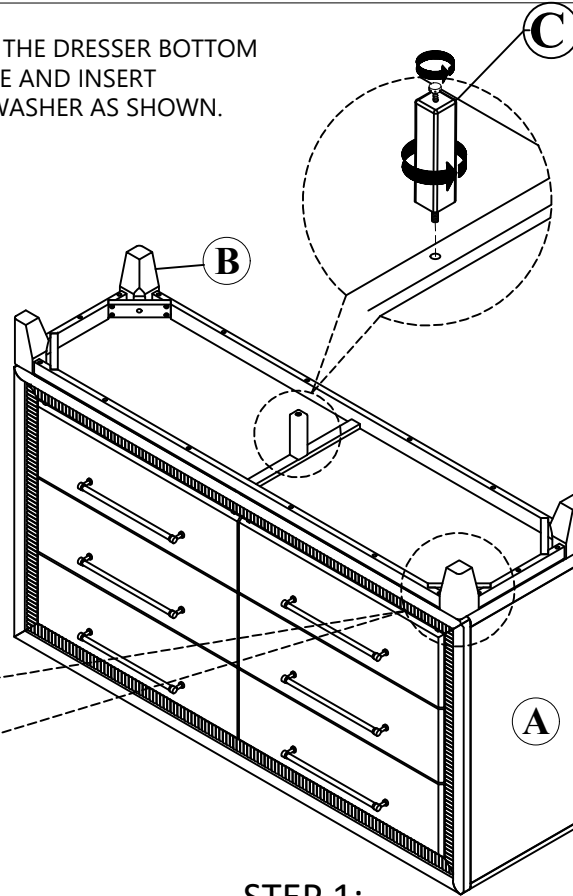
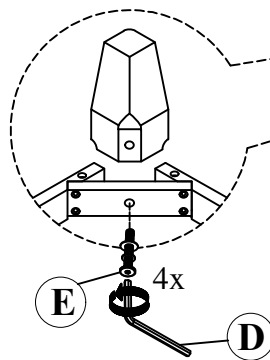

STEP 2 : Move the Dresser (A) into final position and use tipping restraint (F) attach to wall

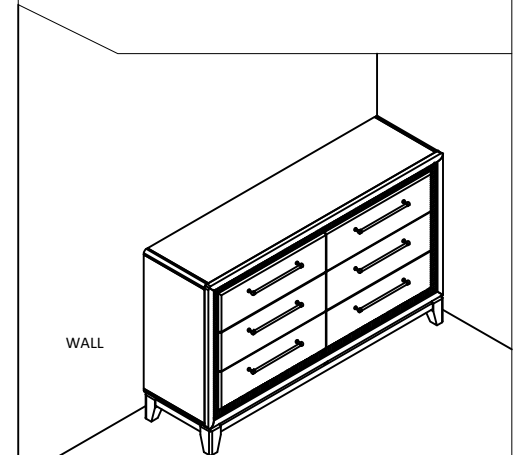
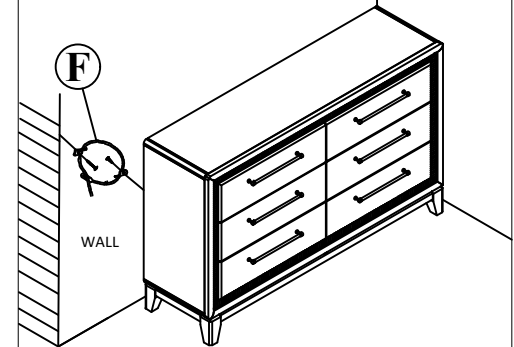

COMPLETED ASSEMBLY

MADE IN MALAYSIA

NOTE: MUST TIGHTEN SCREW PERIODICALLY. WITH USE SCREWS WILL BECOME LOOSE CHECK TIGHT OF ALL SCREWS EVERY 6-8 WEEKS.
CLEANING INSTRUCTION

After assembled, clean & polish the complete parts if necessary with soft cloth and industrial recognized furniture polish.

THE ANTI TIPPING HARDWARE IS LOCATED IN THE 1ST RIGHT SIDE FRONT DRAWER OF DRESSER

THE HARDWARE IS LOCATED IN THE PACKING ITEMS