

ASSEMBLY INSTRUCTIONS

Model: B5520-K-HBFB + B5520-KQ-Rail

(BOX 1) Box of Headboard		
NO.	Descriptions	Qty.
A	Headboard Panel	1
B	Headboard Leg Right (R)	1
C	Headboard Leg Left (L)	1
D	Footboard Panel	1
E	Slat Support	5
F	Bed Slat (With Stopper)	2
G	Bed Slat	3
H	Slat Panel	1

(BOX 1) Box of Headboard (Hardware List)		
NO.	Descriptions	Qty.
1	JCBC Screw M6 x50mm	5
2	JCBC Screw M6 x30mm Spring Washer Ø 1/4"	6
3	CSK M4 x 16mm	18
4	CSK M4 x 32mm	10
5	L Key M4	1
6	L Key M5	1

(BOX 2) Box of Side Rail		
NO.	Descriptions	Qty.
H	Slat Panel	5
I	Center Slat	1
J	Side Rail	2

STEP 1

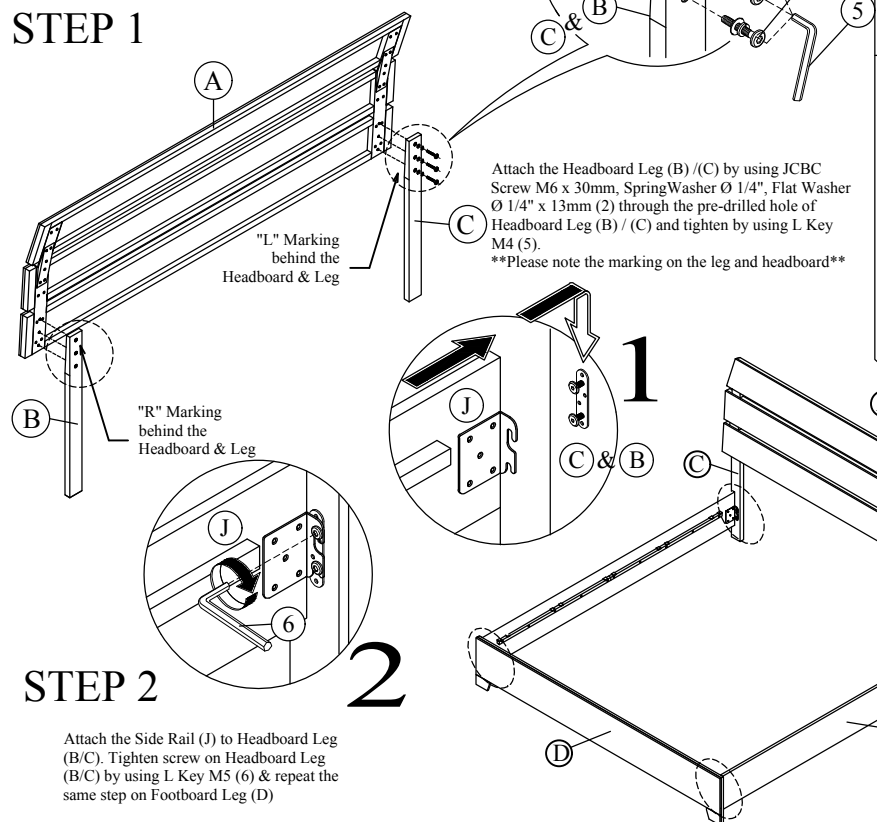

STEP 2

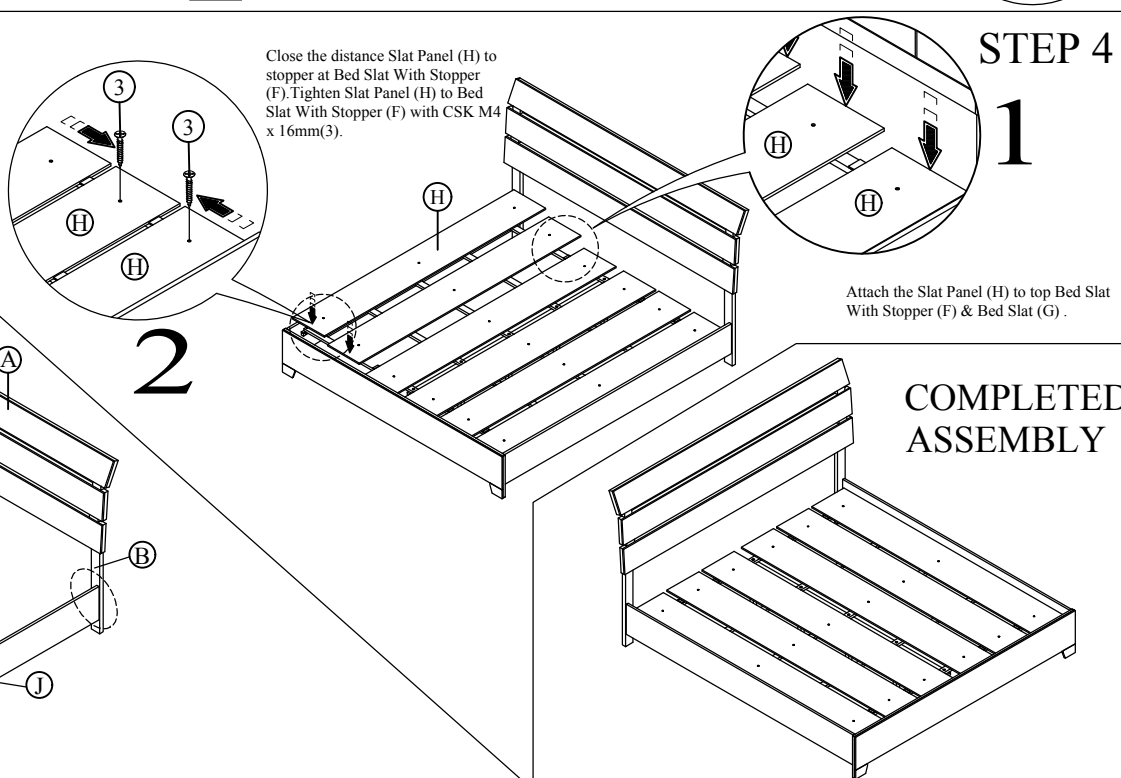
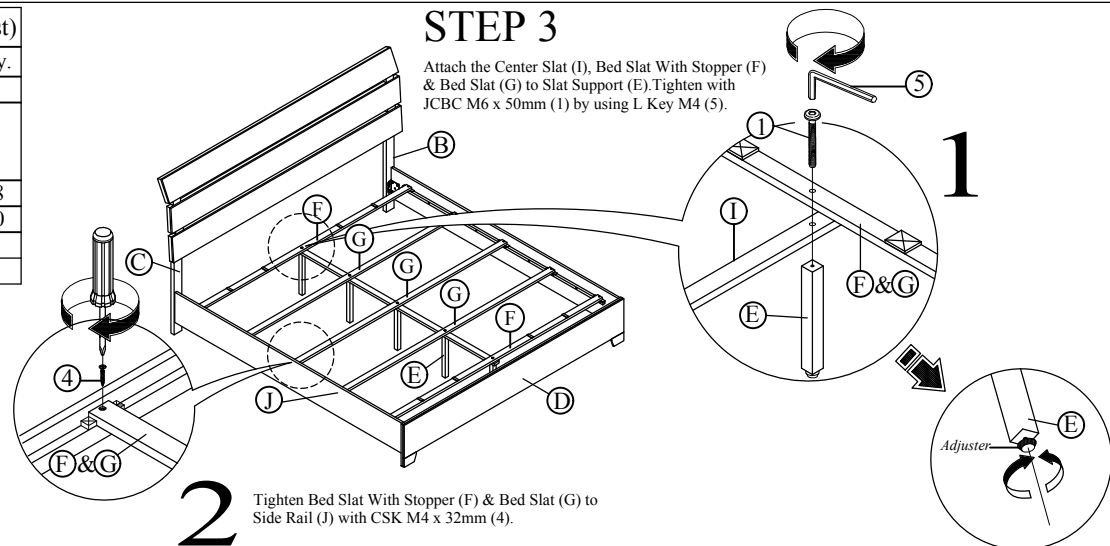

The Hardware is located in the Packing Items