

ASSEMBLY INSTRUCTIONS



CROWNMARK :
B4712-T-HBFB/B4712-T-RAIL
B4715-T-HBFB/B4715-T-RAIL
TWIN BED (4+0)

STEP 1 : Attach Head Board Leg (C) to Head Board (A) as shown using JCBC BOLT (1)with Spring Washer (2), Flat washer (3) and securing with ALLEN KEY (4) .

STEP 2 : Hook SIDE RAIL (D) TO HEAD BOARD (A) closely and push down to fit. repeat step 2 with other end of rail to hook onto FOOTBOARD (B).

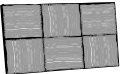

(BOX 1)

BOX OF HEADBOARD

NO	ITEM	QTY
A	HEADBOARD 	1 PC
B	FOOTBOARD 	1 PC
C	HB LEG L&R 	2 PCS

(BOX 2)

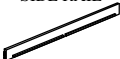
BOX OF SIDE RAIL



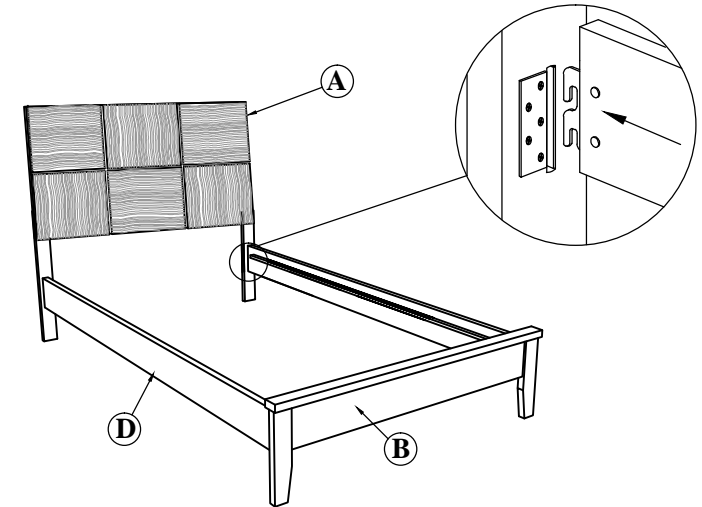
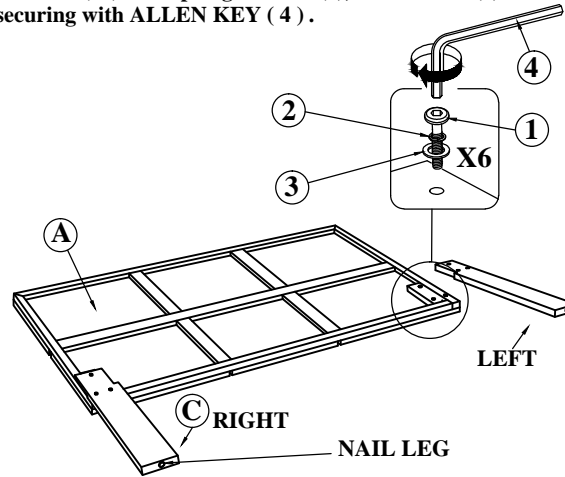

NO	ITEM	QTY
D	SIDE RAIL 	2 PCS
E	BED SLAT 	4 PCS



Fix the Bed Slats (E) as Shown and fix the Bed Slats to Side Rail (D) by using Flat Head Chipboard Screw (5).

(BOX 1)

HARDWARE LIST

NO	ITEM	QTY
1	JCBC BOLT M6 x 30MM BLK 	6 PCS
2	SPRING WASHER 1/4" RBW 	6 PCS
3	FLAT WASHER 1/4" ID x 13mmOD BLK 	6 PCS
4	ALLEN KEY m4 x 65mm BLK 	1 PC

(BOX 2)

HARDWARE LIST

NO	ITEM	QTY
5	FLAT HEAD CHIPBOARD SCREW m4 x 32mm RBW 	8 PCS

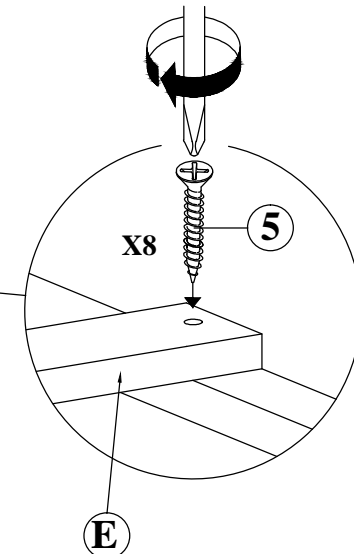
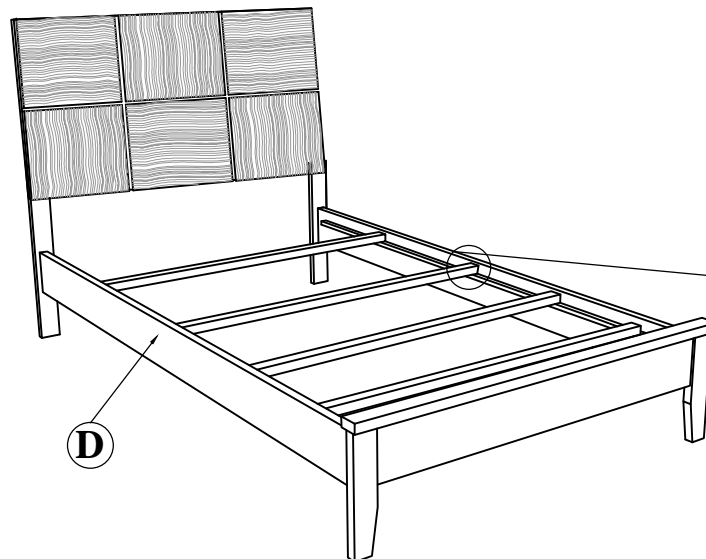

NOTE : MUST TIGHTEN SCREWS PERIODCALLY WITH USE SCREW WILL BECOME LOOSE CHECK TIGHTNESS OF ALL SCREW EVERY 6-8 WEEKS.