

ASSEMBLY INSTRUCTIONS

CROWNMARK
B4610/B4620-K-HBFB-KQ-RAIL
KING (4+8)

(Box 1)
 BOX OF HEADBOARD & FOOTBOARD

No	ITEM	Qty
A	Headboard	1 pc
B	Footboard	1 pc
C	Headboard Leg (L/R)	2 pcs
D	Bed Slats	4 pcs
E	Bed Slats Support	8 pcs

(Box 2)
 BOX OF SIDE RAIL

No	ITEM	Qty
F	Side Rail	2 pcs

(Box 1)
 HARDWARE LIST

No	ITEM	Qty
1	Csk M4 x 32mm	8 pcs
2	JCBC M6 x 30mm	6 pcs
3	SPRING WASHER 1/4" Rbw	6 pcs
4	Flat Washer 1/4"ID x 13mmOD Blk	6 pcs
5	ALLEN KEY m4x65mm Blk	1 pc
6	ALLEN KEY m5x65mm Blk	1 pc

STEP 1 : Attach Head Board Leg (B) to Head Board (A) as shown using JCBC BOLT (2)with Spring Washer (3), Flat washer (4) and securing with ALLEN KEY (5).

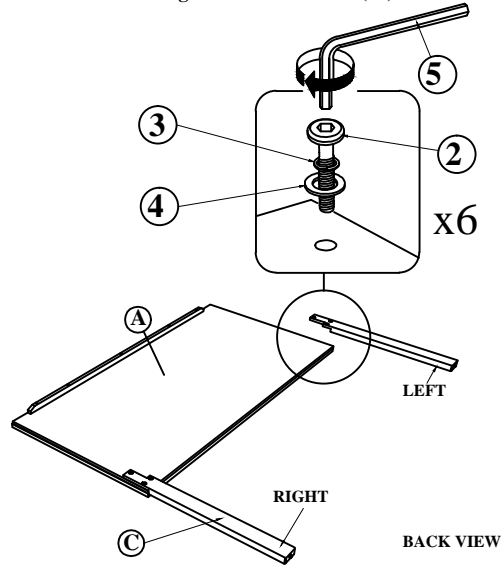

STEP 2 : Hook SIDE RAIL (F) TO HEAD BOARD (A) closely and push down to fit. repeat step 2 with other end of rail to hook onto FOOTBOARD (B).

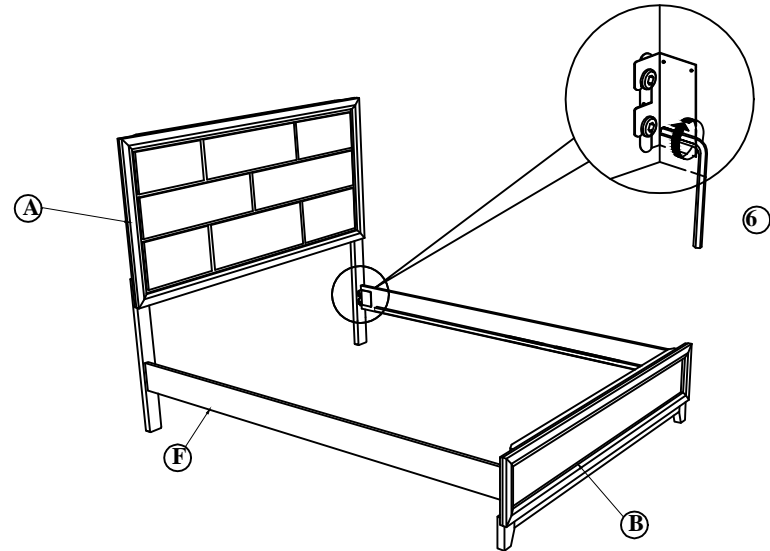

STEP 3 : Tighten the 4 Corner with Allen Key (6). Fix the Bed Slat Support Leg (E), to Bed Slat (D) as shown . Install the bed slat (D) to side rail (F) and tighten with Csk Screw (1) as per diagram shown. (NOTE: THE SETUP MUST DONE AT THE DECIDED LOCATION FOR THE BED TO OBTAIN PERFECT STABILITY)

STEP 3.2 :

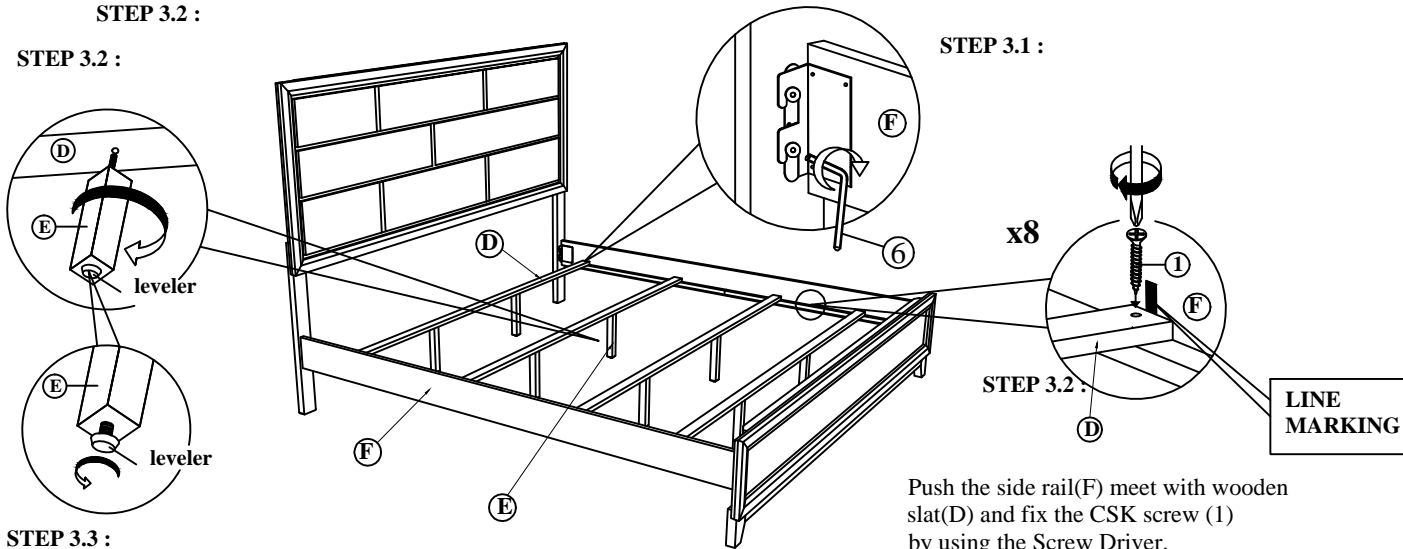

NOTE : MUST TIGHTEN SCREWS PERIODCALLY WITH USE SCREW WILL BECOME LOOSE CHECK TIGHTNESS OF ALL SCREW EVERY 6-8 WEEKS.