

ASSEMBLY INSTRUCTION

CROWNMARK
MODEL : B4390-1/B4390-11
DRESSER & MIRROR

(Box 1)
 BOX OF MIRROR

| NO | ITEM | Qty |
|----|--------|------|
| A | MIRROR | 1 PC |

(Box 2)
 BOX OF DRESSER

| NO | ITEM | Qty |
|----|---------|------|
| B | DRESSER | 1 PC |

(Box. 1)
 BOX OF MIRROR

| NO | ITEM | Qty |
|----|---------------------|-------|
| C | MIRROR SUPPORT RAIL | 2 PCS |

(Box. 1)
 HARDWARE LIST

| NO | ITEM | Qty |
|----|----------------------------------|-------|
| 1 | JCBC BOLT M6 x 35MM BLK | 4 PCS |
| 2 | JCBC BOLT M6 x 40MM BLK | 4 PCS |
| 3 | SPRING WASHER 1/4" RBW | 8 PCS |
| 4 | FLAT WASHER 1/4" ID x 19mmOD BLK | 8 PCS |
| 5 | ALLEN KEY m4 x 65mm BLK | 1 PC |

STEP 1
 Draw out mirror support (C) from the carton box.

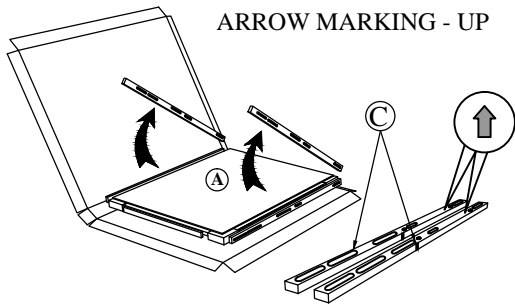

STEP 2 : Align & fasten mirror support (C) to the back of mirror (A) using short JCBC bolt(1), spring washer (3) & flat washer (4). **DO NOT FULLY TIGHTEN AT THIS STEP.**
 Note : Make sure arrow marking of the mirror support (C) is aligned up.

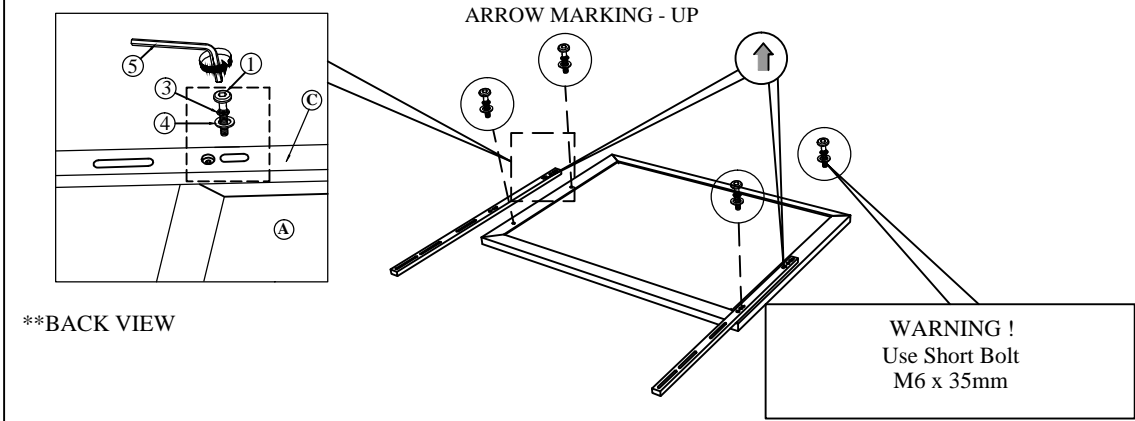

STEP 3 : Place mirror (A) on top of dresser (B). Align & fasten mirror support (C) to the back of dresser (B) using long JCBC bolt (2) , spring washer (3) & flat washer (4) **THEN FULLY TIGHTEN ALL THE BOLTS AT STEP 2 & 3 WITH ALLEN KEY (5).**

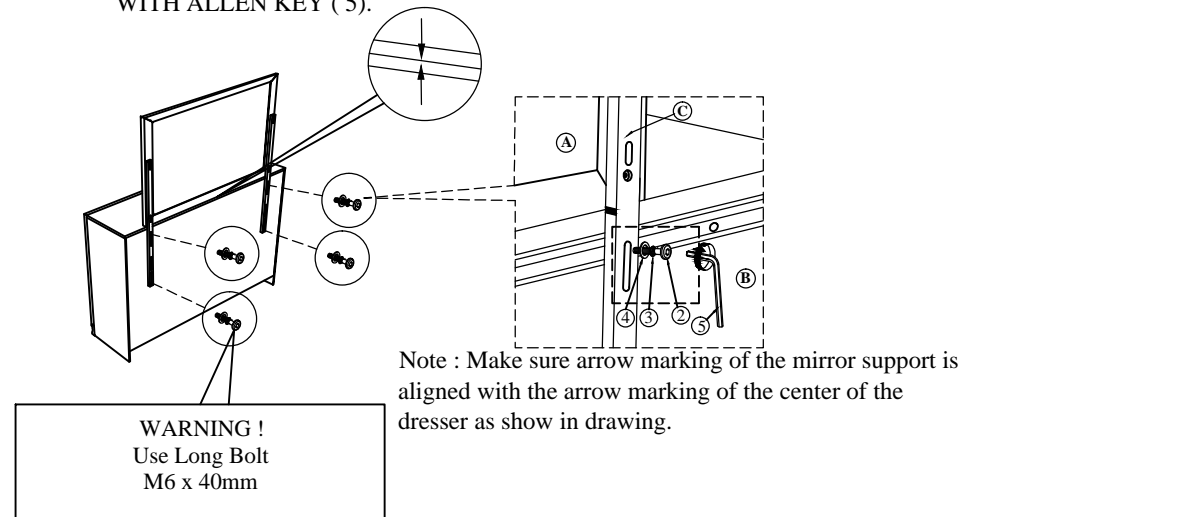

****HARDWARE SET IS IN 1857-6 FOR ASSEMBLY**

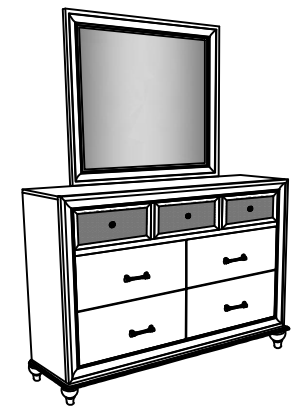

COMPLETED ASSEMBLY

NOTE : MUST TIGHTEN SCREWS PERIODCALLY WITH USE SCREW WILL BECOME LOOSE CHECK TIGHTNESS OF ALL SCREW EVERY 6-8 WEEKS.