

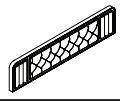



ASSEMBLY INSTRUCTIONS

ITEM NO : B2150-Q-FB / B2150-KQ-RAIL / B2150-Q-HBWG
QUEEN BED

**(BOX 1)
BOX OF FOOTBOARD**

ITEM	DRAWING	DESCRIPTION	QTY
A		FOOTBOARD	1
B		BUN FOOT	2
C		WOODEN SLAT	4
D		WOODEN SUPPORT WITH ADJUSTER	4



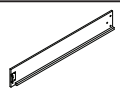



**(BOX 2)
BOX OF SIDE RAIL**

ITEM	DRAWING	DESCRIPTION	QTY
E		SIDE RAIL (L / R)	2

**(BOX 3)
BOX OF HEADBOARD WING**

ITEM	DRAWING	DESCRIPTION	QTY
F		HEADBOARD WING (L / R)	2

**(BOX 1)
HARDWARE LIST**

ITEM	DRAWING	DESCRIPTION	QTY
1		ALLEN KEY (M4)	1
2		CONNECTION BOLT (M6 x 30mm) W/SPRING WASHER & WASHER MEDIUM	4
3		CONNECTION BOLT (M6 x 40mm) W/SPRING WASHER & WASHER MEDIUM	6
4		CONNECTION BOLT (M6 x 60mm) W/SPRING WASHER & WASHER MEDIUM	6
5		CONNECTION BOLT (M6 x 40mm)	4
6		CSK SCREW (M4 x 32mm)	8
7		SCREW DRIVER (*)	1

(*) The Manufacturer does not provide item 7.

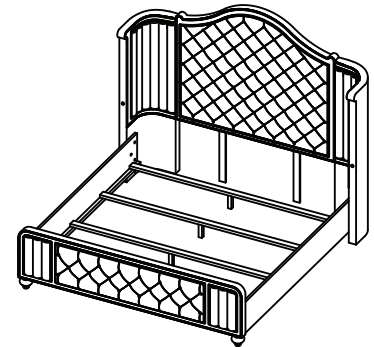

**COMPLETED QUEEN BED
ASSEMBLY**

STEP 1

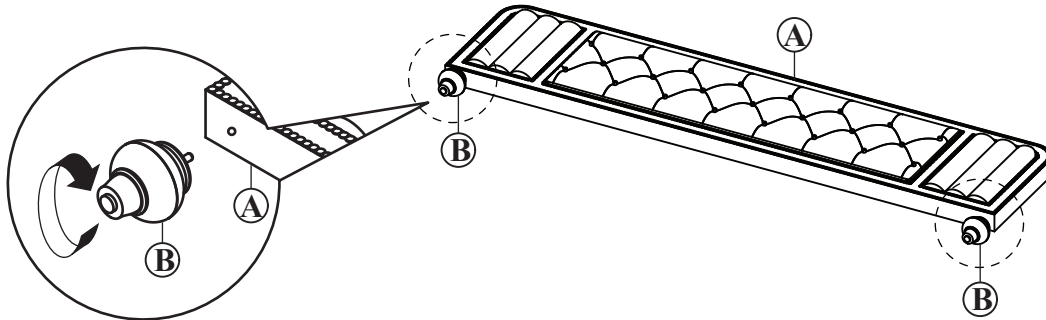

STEP 2

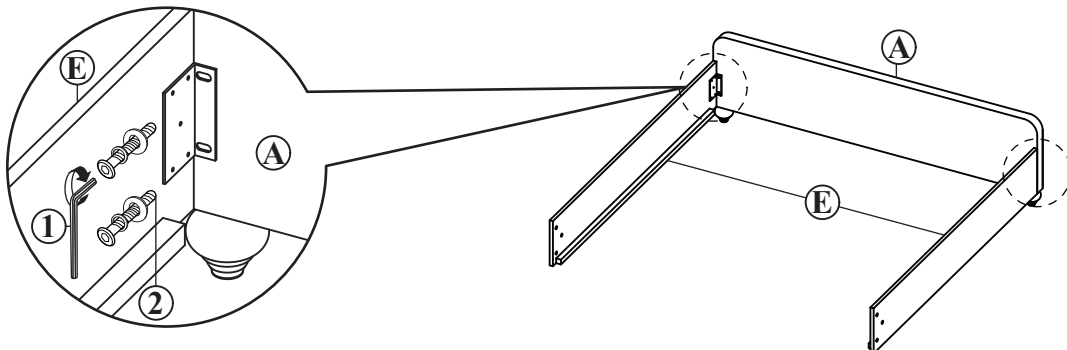

THE HARDWARE IS LOCATED IN THE PACKING ITEMS.

NOTE : MUST TIGHTEN BOLTS & SCREWS PERIODICALLY. WITH USE BOLTS & SCREWS MAY BECOME LOOSE.
CHECK TIGHTNESS OF ALL BOLTS & SCREWS EVERY 6-8 WEEKS.

CLEANING INSTRUCTION

After assembly, clean & polish the completed parts if necessary with soft cloth and industrial recognized furniture polish

MADE IN MALAYSIA

ASSEMBLY INSTRUCTIONS

ITEM NO : B2150-Q-FB / B2150-KQ-RAIL / B2150-Q-HBWG
QUEEN BED

STEP 3

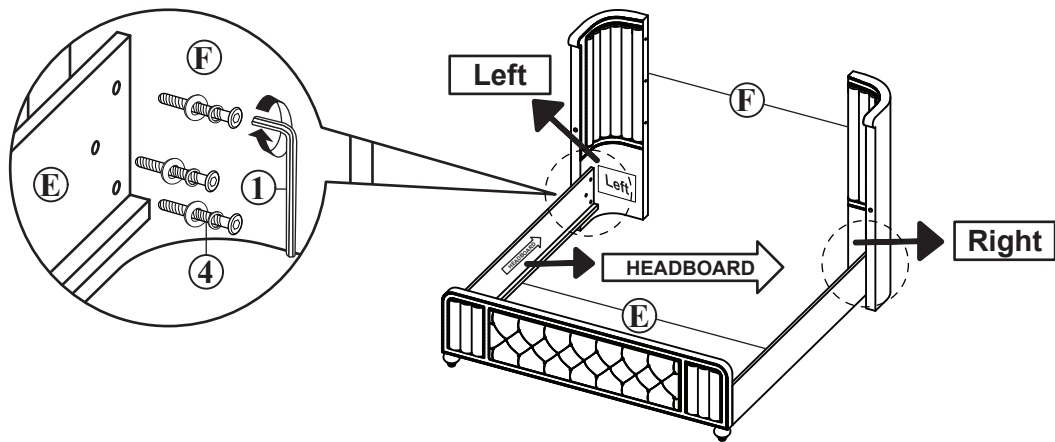

STEP 4

Please refer ITEM NO : B2150-K-HB / B2150-Q-HB

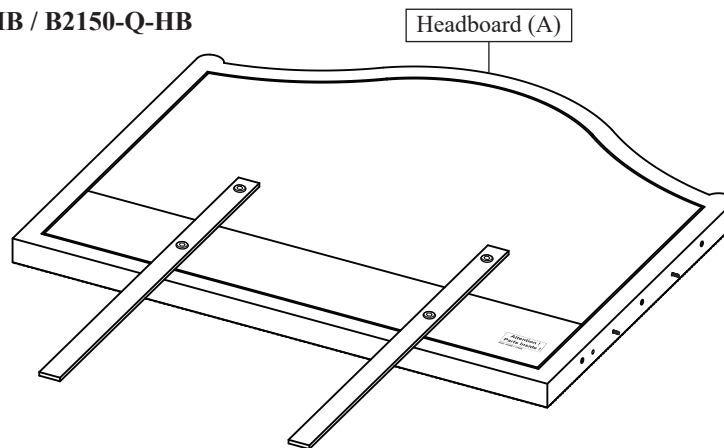

STEP 5

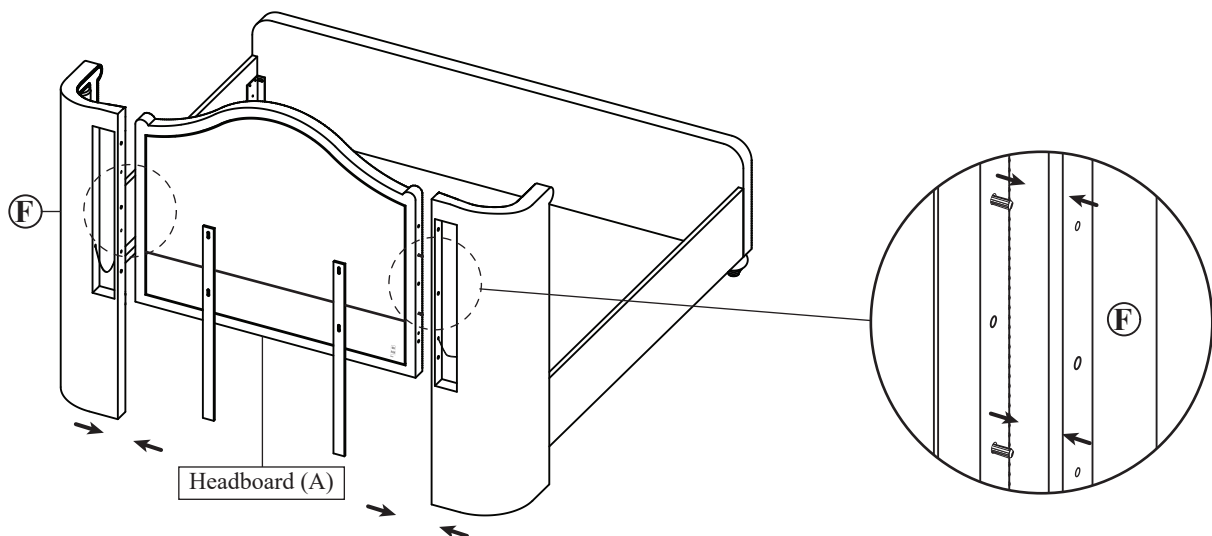

THE HARDWARE IS LOCATED IN THE PACKING ITEMS.

NOTE : MUST TIGHTEN BOLTS & SCREWS PERIODICALLY. WITH USE BOLTS & SCREWS MAY BECOME LOOSE.
CHECK TIGHTNESS OF ALL BOLTS & SCREWS EVERY 6-8 WEEKS.

CLEANING INSTRUCTION

After assembly, clean & polish the completed parts if necessary with soft cloth and industrial recognized furniture polish

MADE IN MALAYSIA

ASSEMBLY INSTRUCTIONS

ITEM NO : B2150-Q-FB / B2150-KQ-RAIL / B2150-Q-HBWG
QUEEN BED

STEP 6

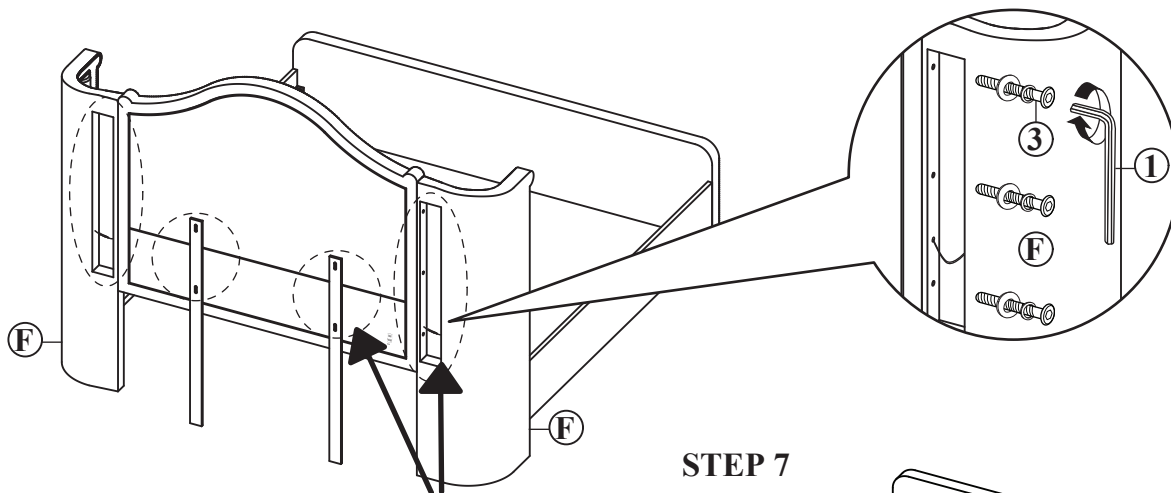

TO TIGHTEN ALL THE
CONNECTION BOLTS.

STEP 7

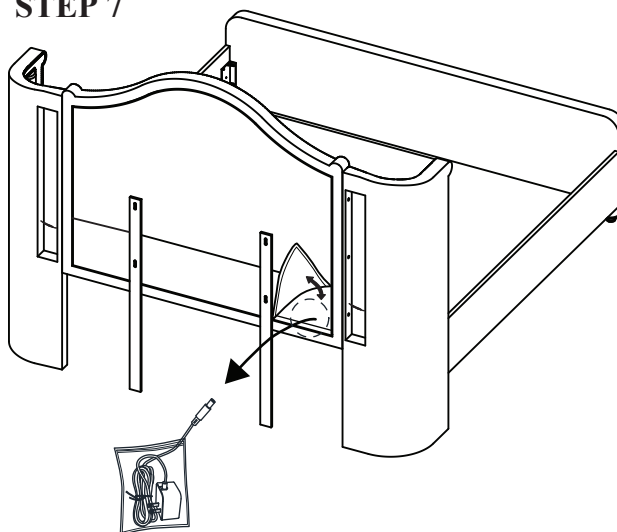

Lift Up the Cover at the Lower End of the Headboard (A).
Take Out the Plastic Bag and Remove the Adapter Plug,
which is Inside the Box.

STEP 8

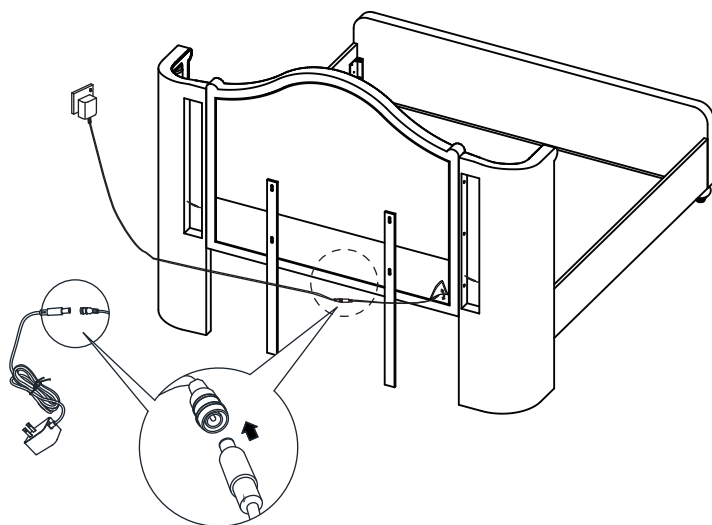

THE HARDWARE IS LOCATED IN THE PACKING ITEMS.

NOTE : MUST TIGHTEN BOLTS & SCREWS PERIODICALLY. WITH USE BOLTS & SCREWS MAY BECOME LOOSE.
CHECK TIGHTNESS OF ALL BOLTS & SCREWS EVERY 6-8 WEEKS.

CLEANING INSTRUCTION

After assembly, clean & polish the completed parts if necessary with soft cloth and industrial recognized furniture polish

MADE IN MALAYSIA

ASSEMBLY INSTRUCTIONS

ITEM NO : B2150-Q-FB / B2150-KQ-RAIL / B2150-Q-HBWG
QUEEN BED

STEP 9

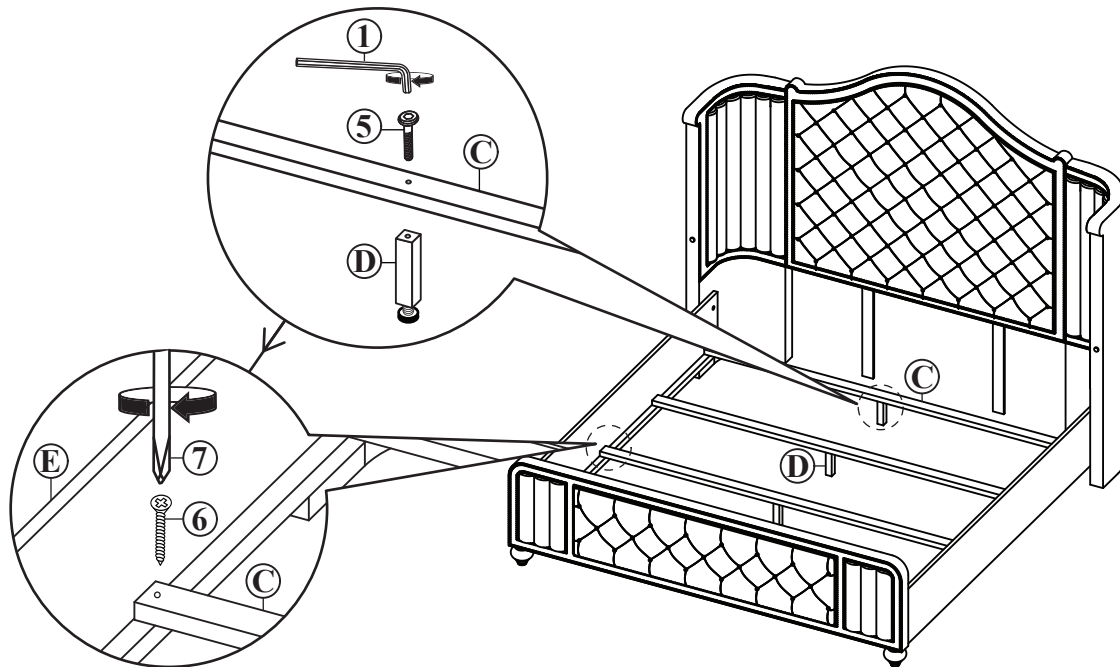

STEP 10

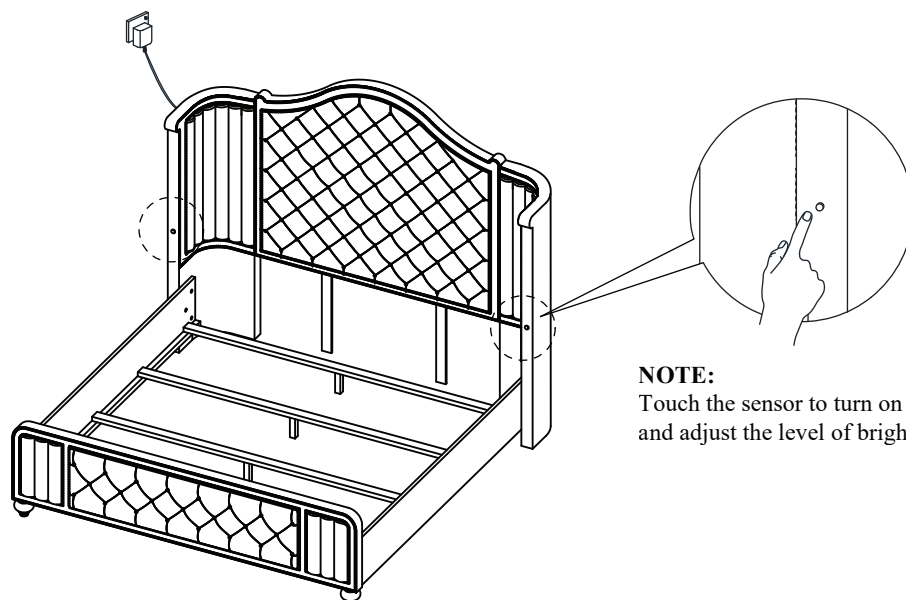

NOTE:
Touch the sensor to turn on the light
and adjust the level of brightness.

THE HARDWARE IS LOCATED IN THE PACKING ITEMS.

NOTE : MUST TIGHTEN BOLTS & SCREWS PERIODICALLY. WITH USE BOLTS & SCREWS MAY BECOME LOOSE.
CHECK TIGHTNESS OF ALL BOLTS & SCREWS EVERY 6-8 WEEKS.

CLEANING INSTRUCTION

After assembly, clean & polish the completed parts if necessary with soft cloth and industrial recognized furniture polish

MADE IN MALAYSIA