

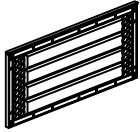

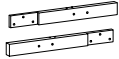
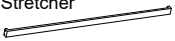

ASSEMBLY INSTRUCTIONS

CROWN MARK MODEL : B1680 KING BED

(BOX 1)
BOX OF HEADBOARD

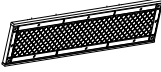
NO	ITEM	QTY
A	Headboard 	1PC
B	K/D Legs (L&R) 	2PCS
C	Stretcher 	1PC



(BOX 2)
BOX OF FOOTBOARD

NO	ITEM	QTY
D	Footboard 	1PC
E	Legs 	2PCS
F	Slats 	4PCS
G	Support legs 	8PCS

(BOX 3)
BOX OF SIDE RAIL

NO	ITEM	Q'TY
H	side rails 	2PCS

(BOX 1)
HARDWARE LIST

NO	ITEM	QTY
1	Ø5/16"-18 x 2" L 	10 SET
2	4mm 	1 PC
3	1-3/16" 	8 PCS

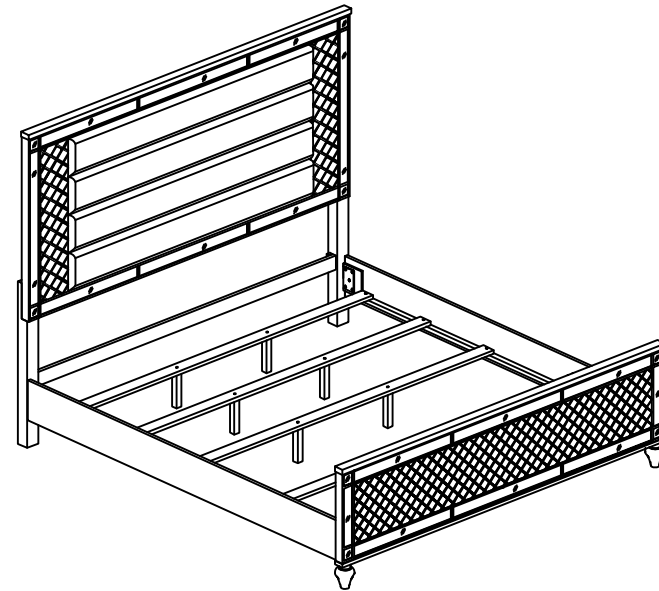

THE HARDWARE IS LOCATED IN THE PACKING ITEMS

NOTE : DURING ASSEMBLY, DO NOT FULLY TIGHTEN ANY HARDWARE UNTIL THE COMPLETE UNIT HAS BEEN ASSEMBLED.

NOTE : MUST TIGHTEN SCREWS PERIODICALLY WITH USE SCREWS WILL BECOME LOOSE.CHECK TIGHTNESS OF ALL SCREWS EVERY 6-8 WEEKS.

STEP 1

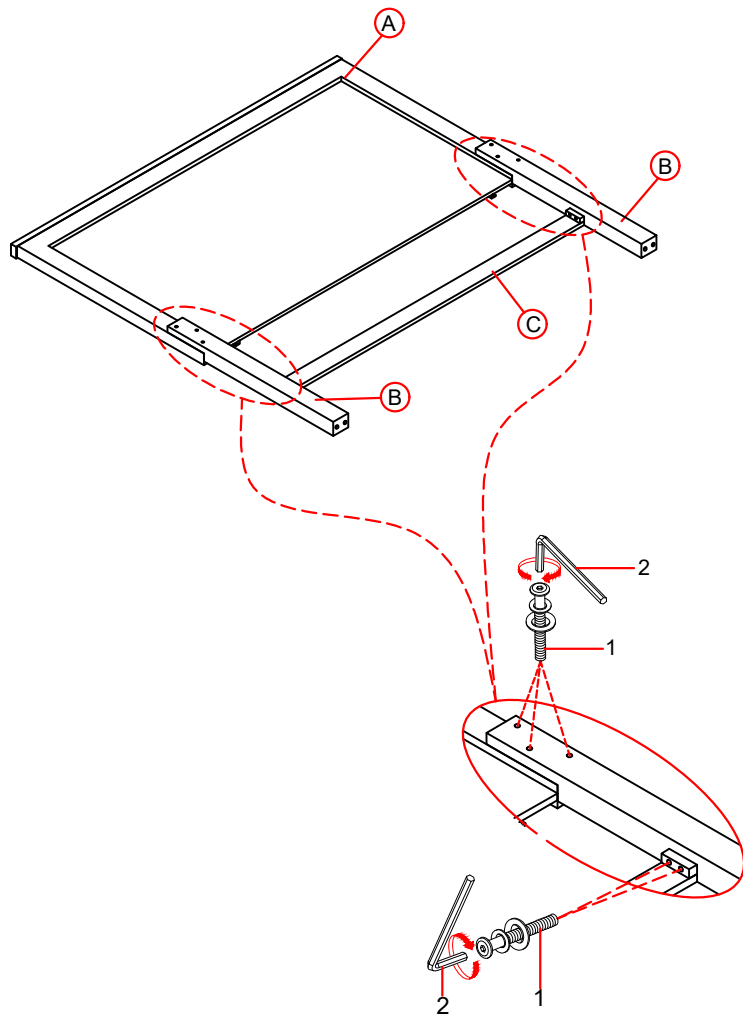

STEP 2

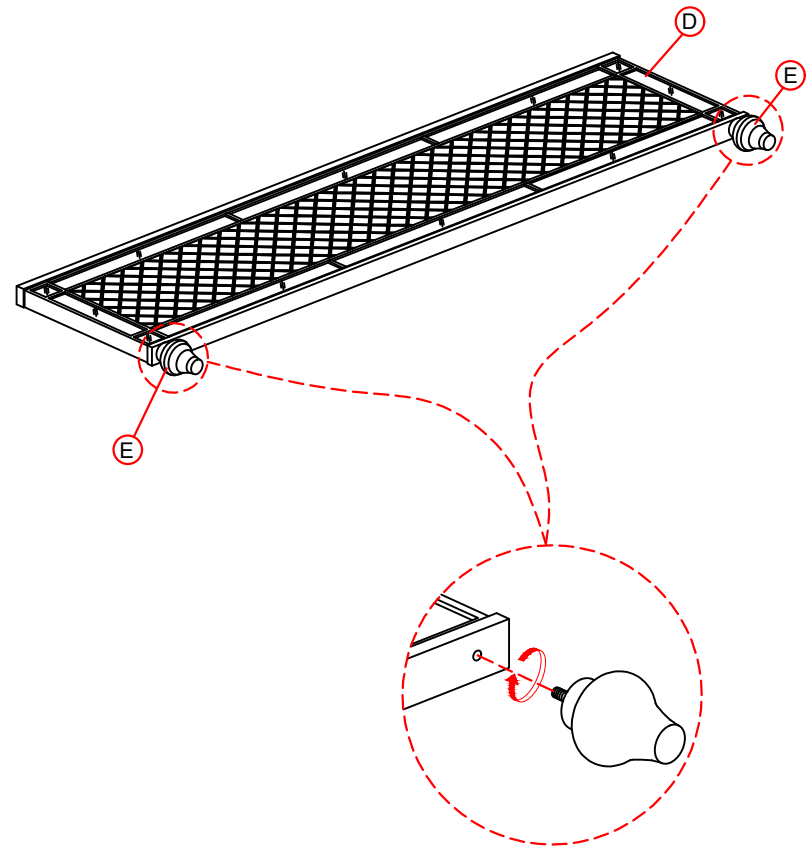

STEP 3

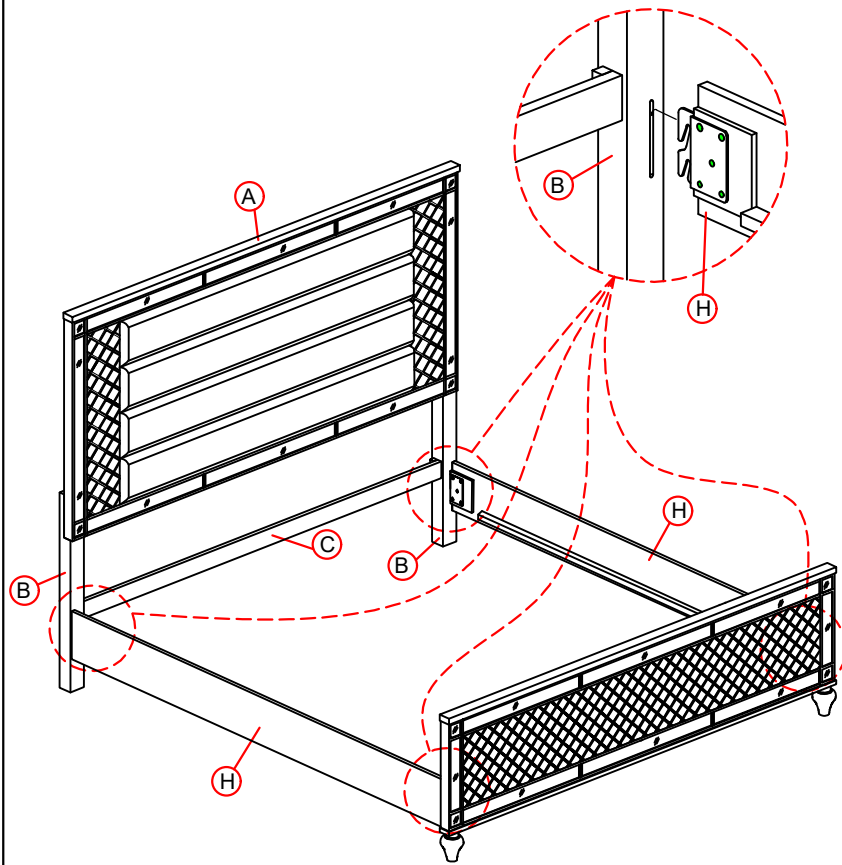

STEP 4

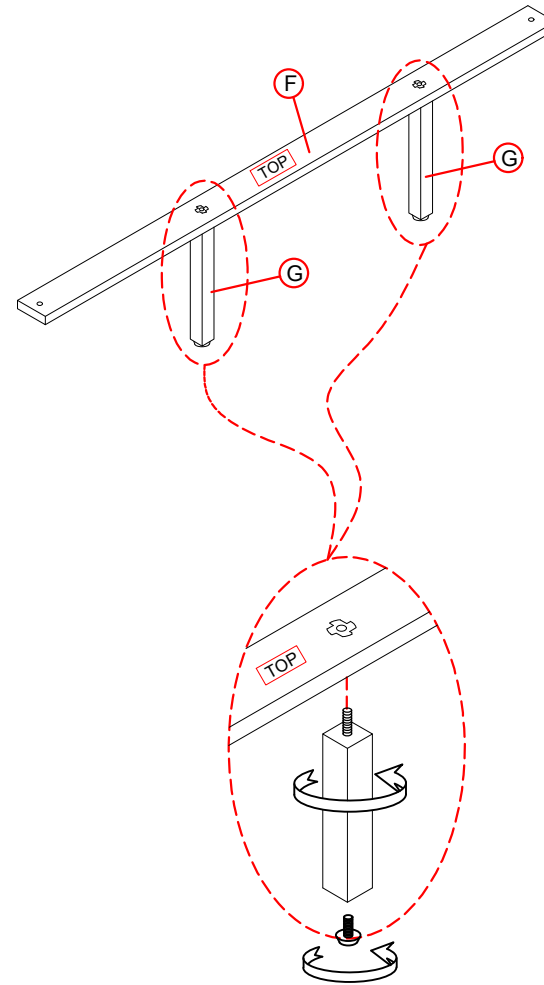

STEP 5

"SCREWDRIVER NOT INCLUDED"

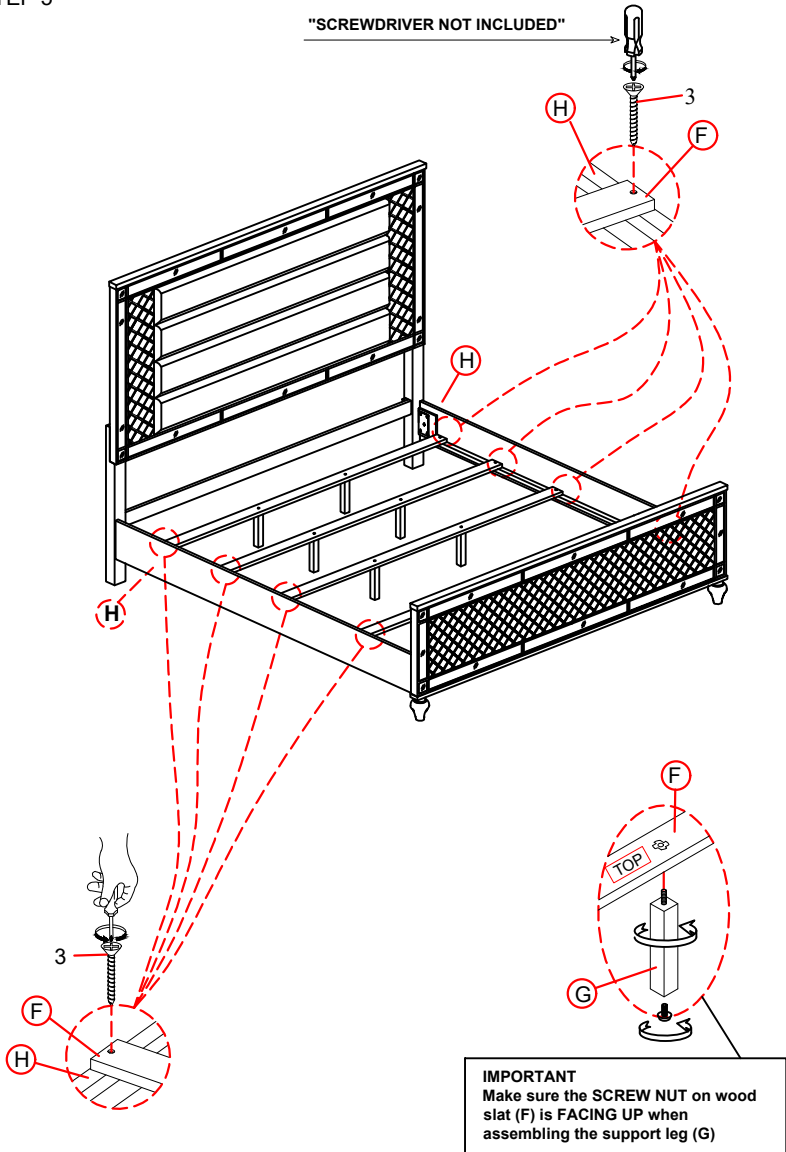

STEP 6
COMPLETED

