

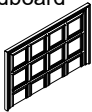
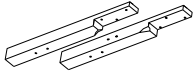
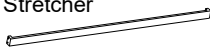

ASSEMBLY INSTRUCTIONS

CROWN MARK MODEL : B1650 KING BED

(BOX 1)
BOX OF HEADBOARD

NO	ITEM	QTY
A	Headboard 	1PC
B	K/D Legs (L&R) 	2PCS
C	Stretcher 	1PC

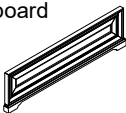



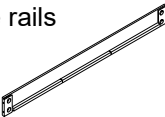

(BOX 2)
BOX OF FOOTBOARD

NO	ITEM	QTY
D	Footboard 	1PC
E	Slats 	4PCS
F	Support legs 	8PCS

(BOX 3)
BOX OF SIDE RAIL

NO	ITEM	Q'TY
G	side rails 	2PCS

(BOX 1)
HARDWARE LIST

NO	ITEM	QTY
1	Ø5/16"-18 x 2" L 	10 SET
2	4mm 	1 PC
3	Ø5/16"X3-1/2" 	8 PCS
4	Ø5/16" 	8 PCS
5	Ø5/16" 	8 PCS
6	12mm 	1 PC
7	1-3/16" 	8 PCS

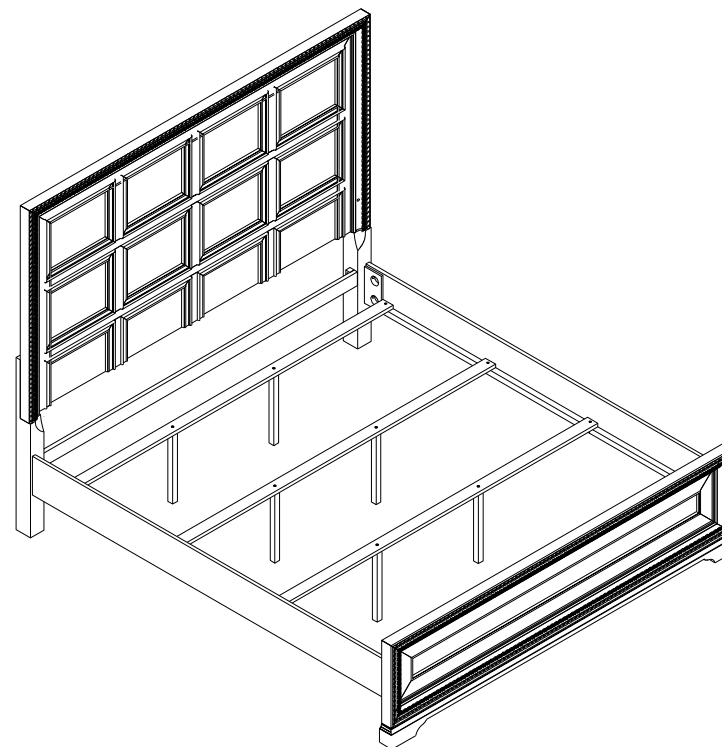

NOTE : DURING ASSEMBLY, DO NOT FULLY TIGHTEN
ANY HARDWARE UNTIL THE COMPLETE
UNIT HAS BEEN ASSEMBLED.

THE HARDWARE IS LOCATED IN THE PACKING ITEMS

STEP 1

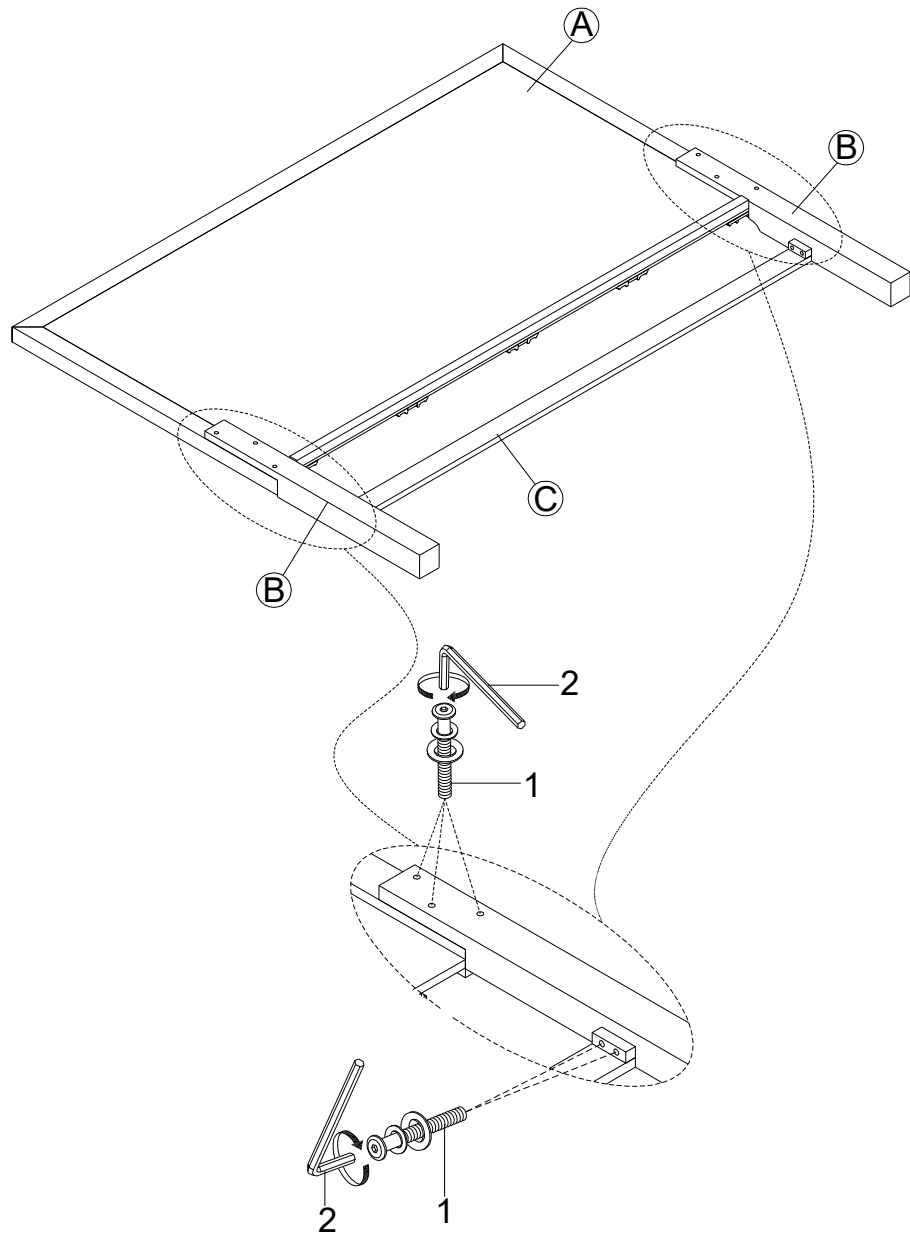

STEP 2

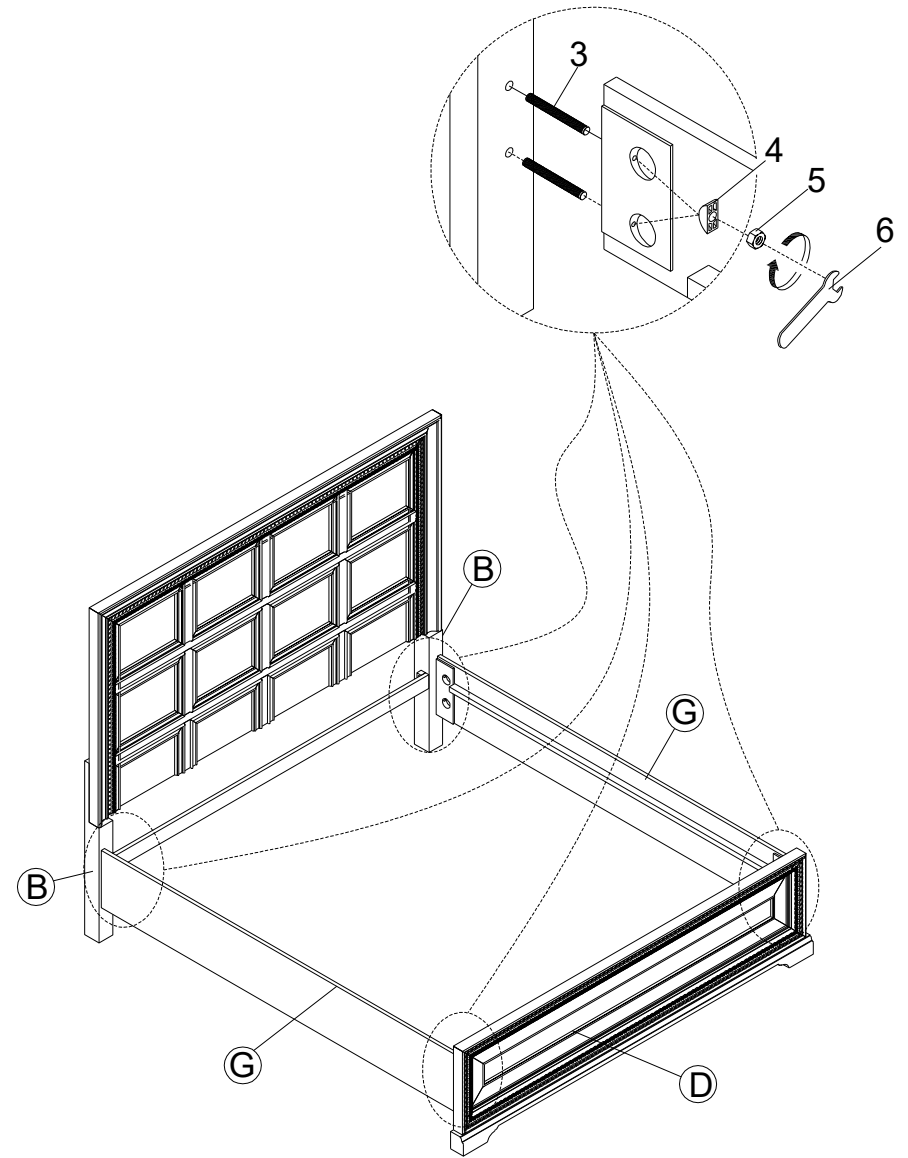

STEP 3

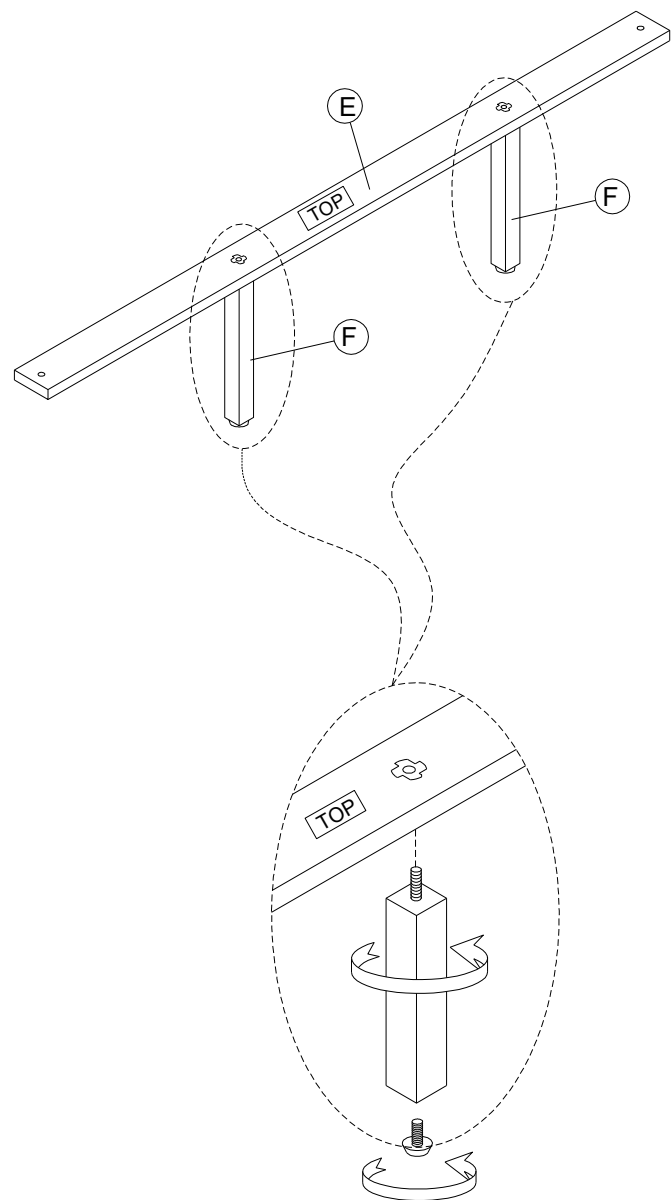

STEP 4

"SCREWDRIVER NOT INCLUDED" →

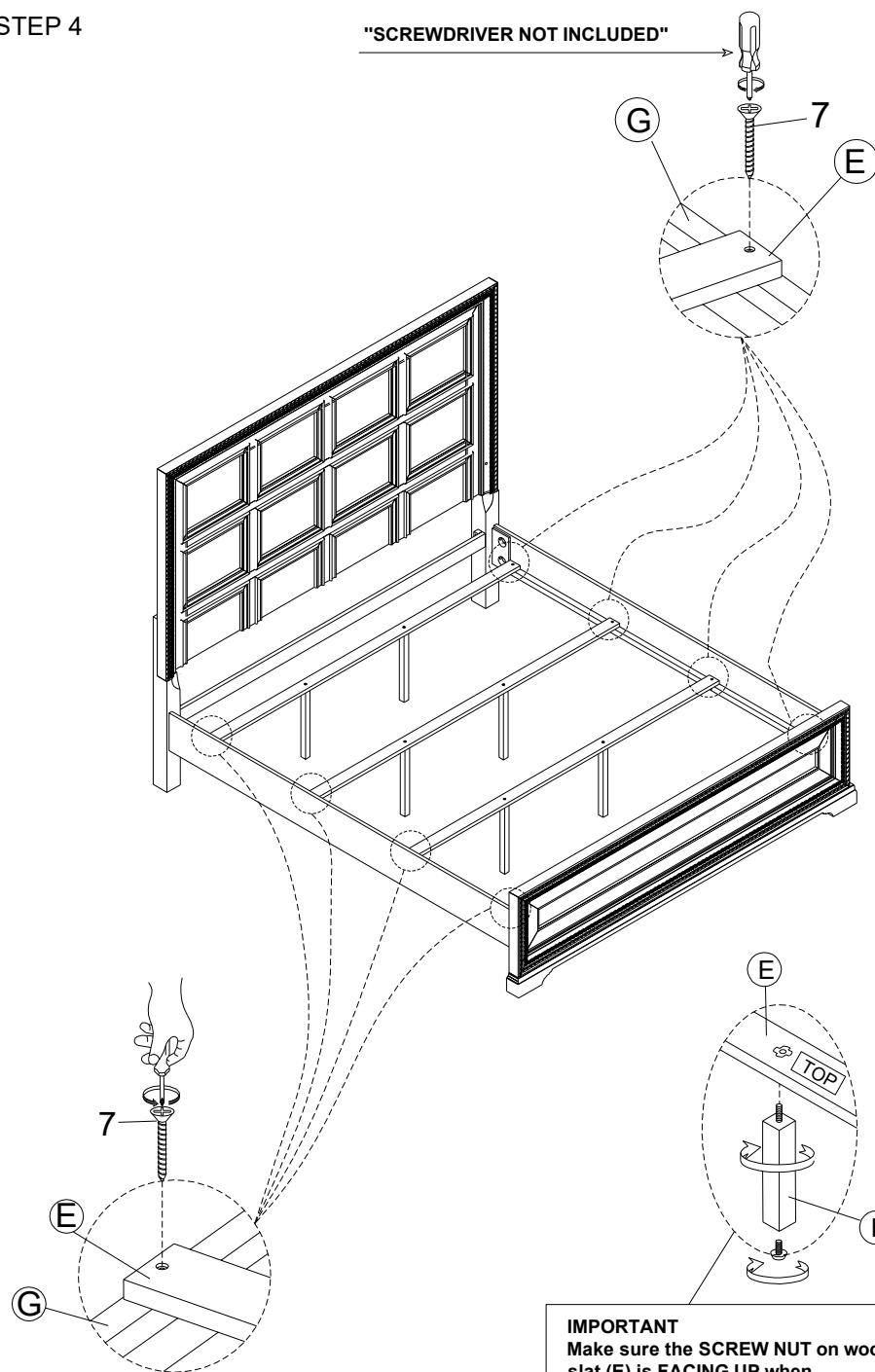

IMPORTANT
Make sure the SCREW NUT on wood slat (E) is FACING UP when assembling the support leg (F)