







# ASSEMBLY INSTRUCTION

**CROWNMARK**  
**MODEL : B1600 QUEEN BED**

(BOX 1)  
BOX OF HEADBOARD

NO	ITEM	QTY
A	Headboard 	1 PC
B	Finial 	1 PC
C	Stretcher 	1 PC

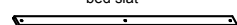
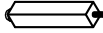

(BOX 2)  
BOX OF FOOTBOARD

NO	ITEM	QTY
F	Footboard 	1 PC
G	bed slat 	4 PCS
H	Support leg 	4 PCS
I	Bun foot 	2 PCS









(BOX 3)  
BOX OF SIDE RAIL

NO	ITEM	QTY
K	Side Rail 	2 PCS

(BOX 4)  
BOX OF HEADBOARD LEG

NO	ITEM	QTY
D	Headboard KD Leg ( L/R) 	2 PCS
E	Bun foot 	2 PCS

(BOX 1)  
HARDWARE LIST

NO	ITEM	QTY
1	Ø5/16" x 18 x 1-3/4" L 	10 PCS
2	Ø5/16" x 18 x 1-1/2" L 	2 PCS
3	Ø5/16" 	1 PC
4	Ø5/16" x 3-1/2" L 	8 PCS
5	5/16" 	8 PCS
6	5/16" 	8 PCS
7	12mm 	1 PC
8	1-3/16" 	8 PCS

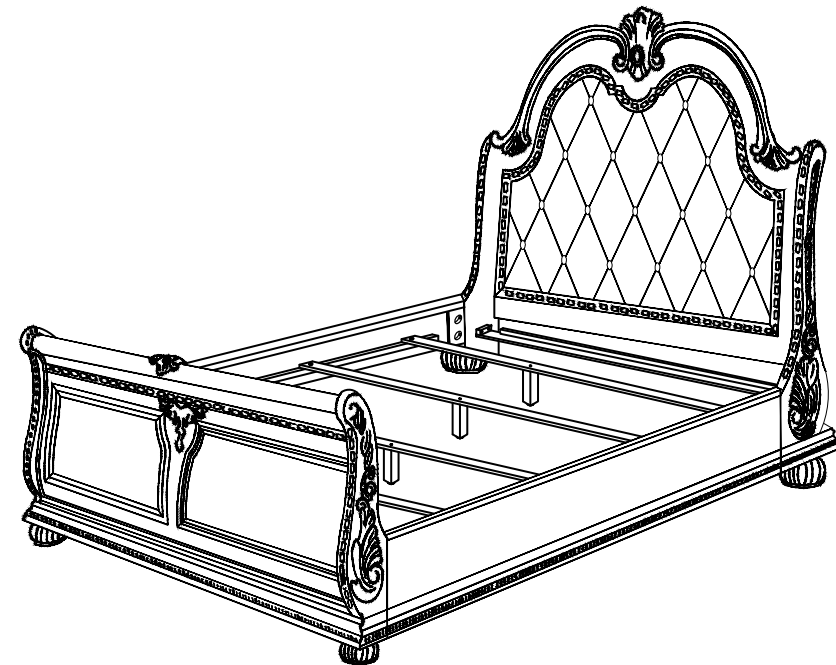

**NOTE : DURING ASSEMBLY, DO NOT FULLY TIGHTEN ANY HARDWARE UNTIL THE COMPLETE UNIT HAS BEEN ASSEMBLED.**

"THE HARDWARE IS LOCATED IN THE PACKING ITEMS"

NOTE : MUST TIGHTEN SCREWS PERIODICALLY WITH USE SCREWS WILL BECOME LOOSE.CHECK TIGHTNESS OF ALL SCREWS EVERY 6-8 WEEKS.

STEP 1

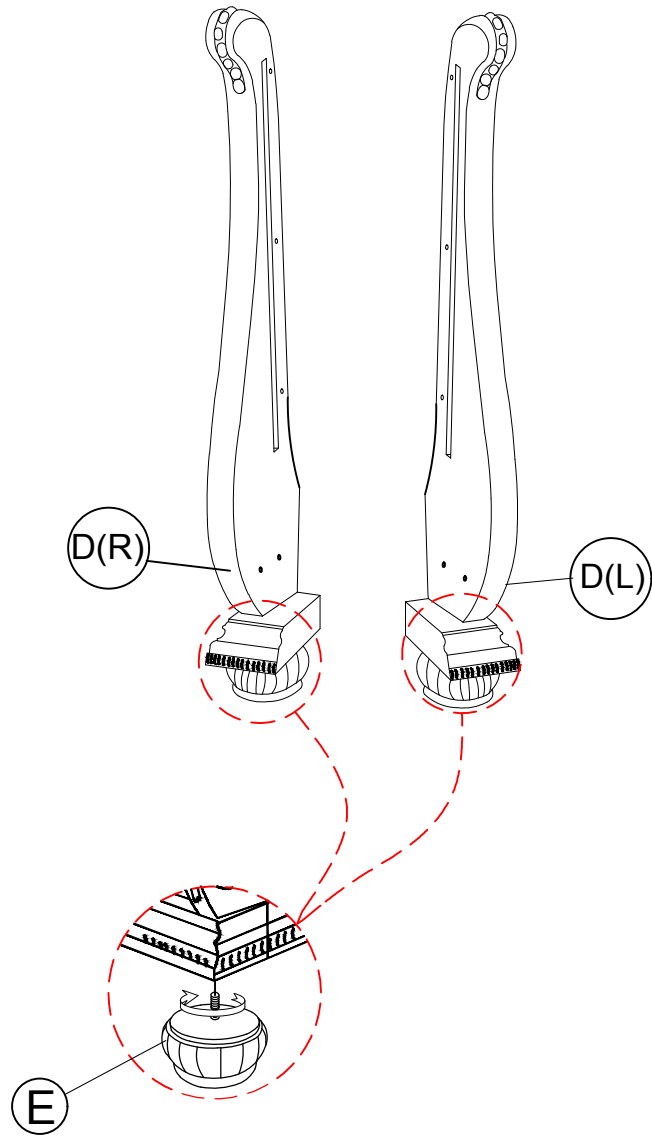

STEP 2

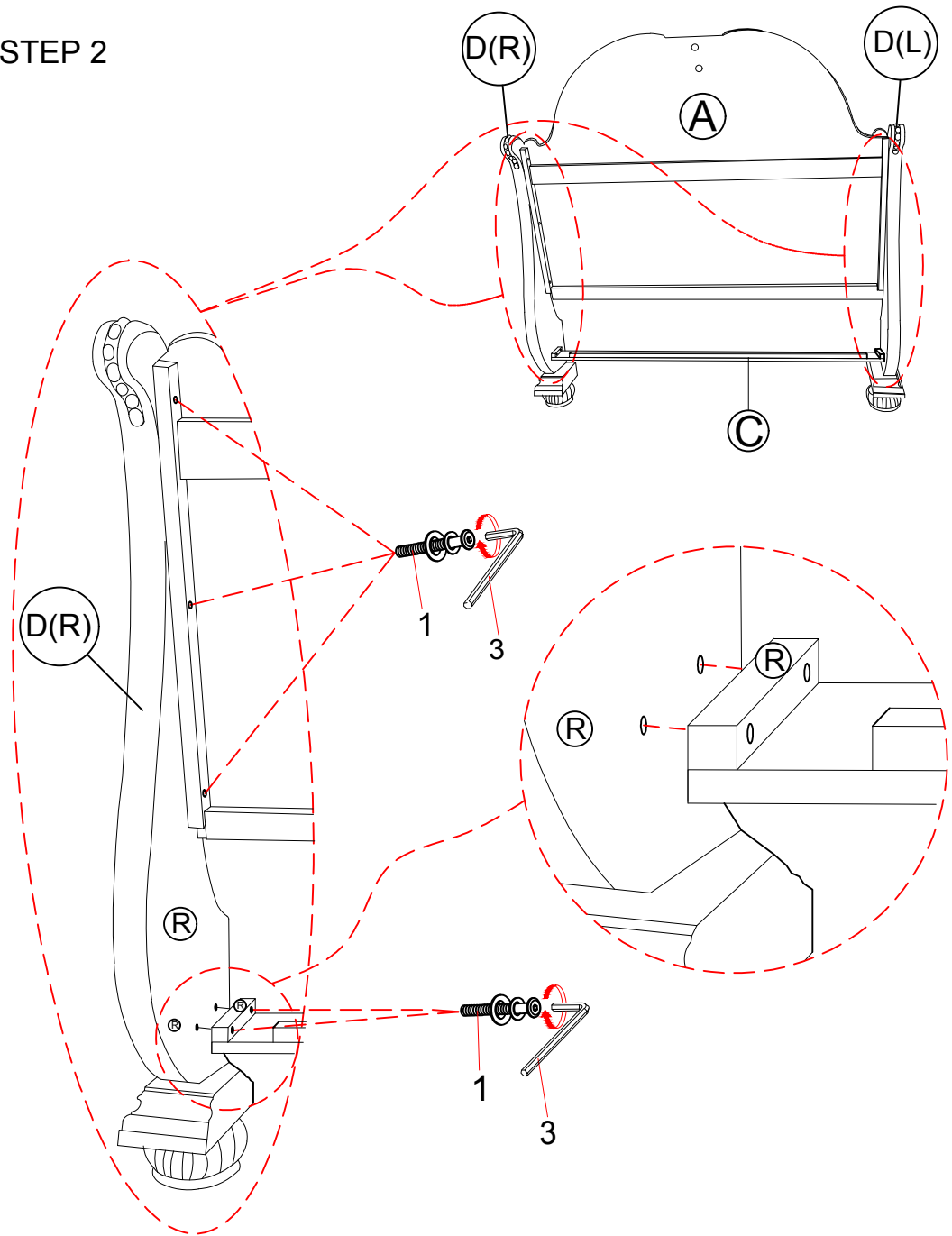

### STEP 3

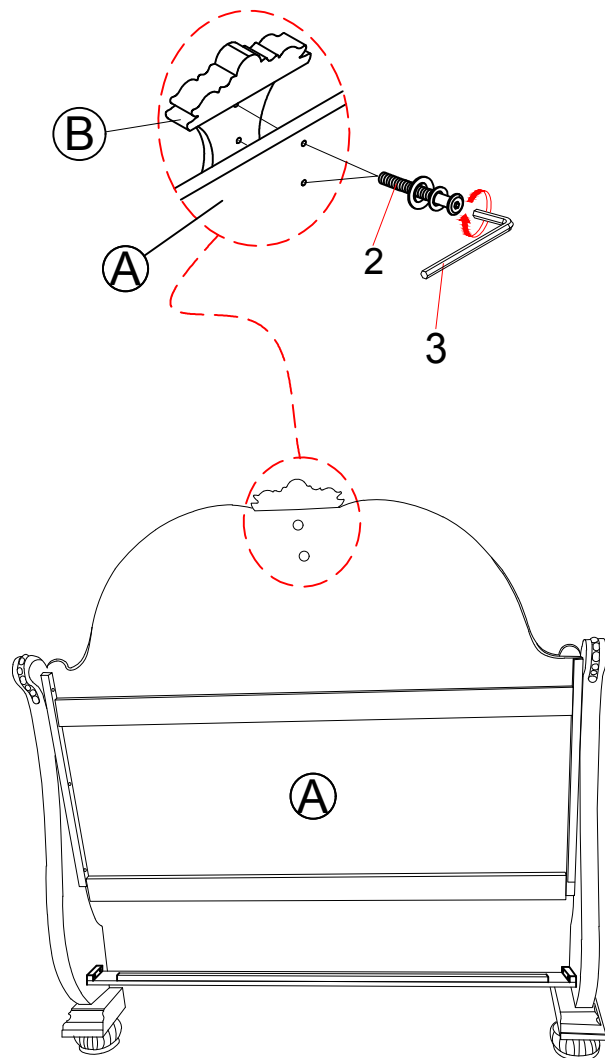

### STEP 4

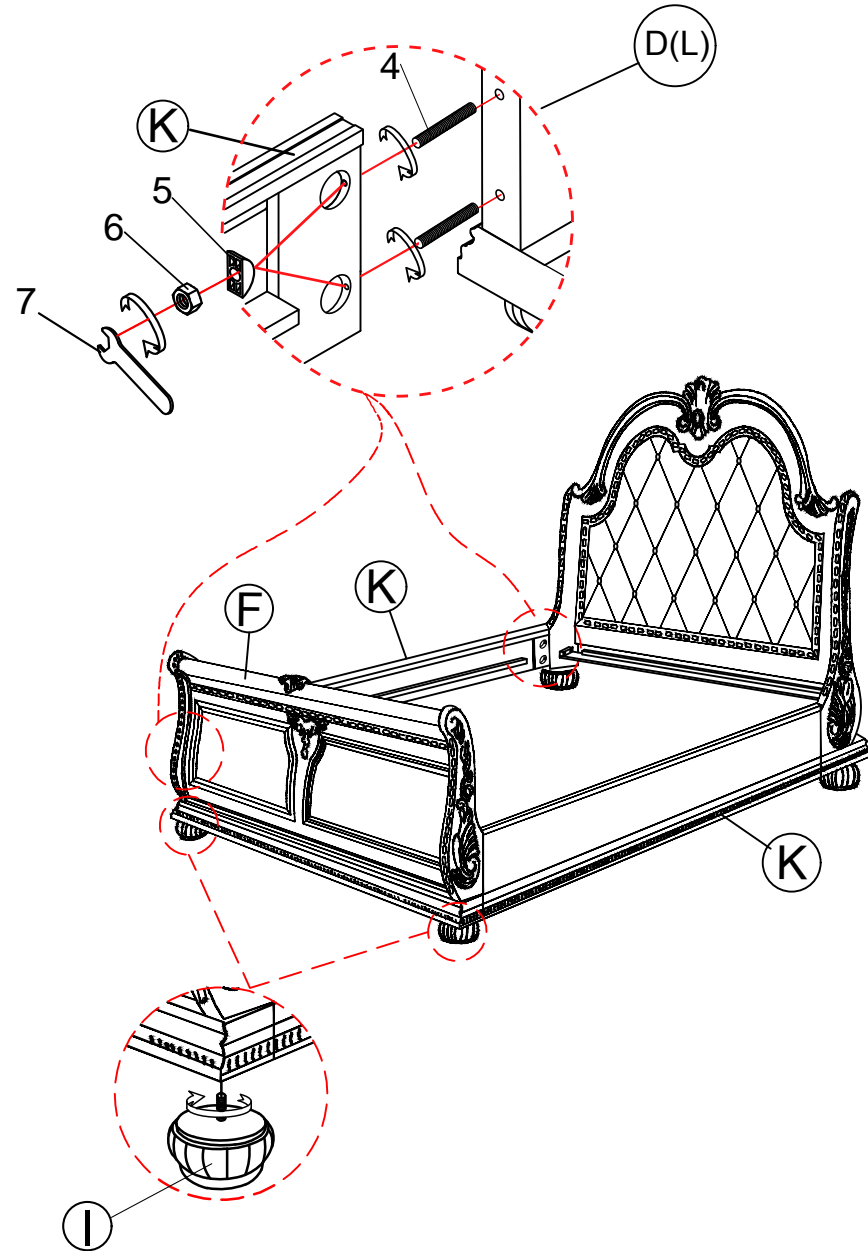

# STEP 5

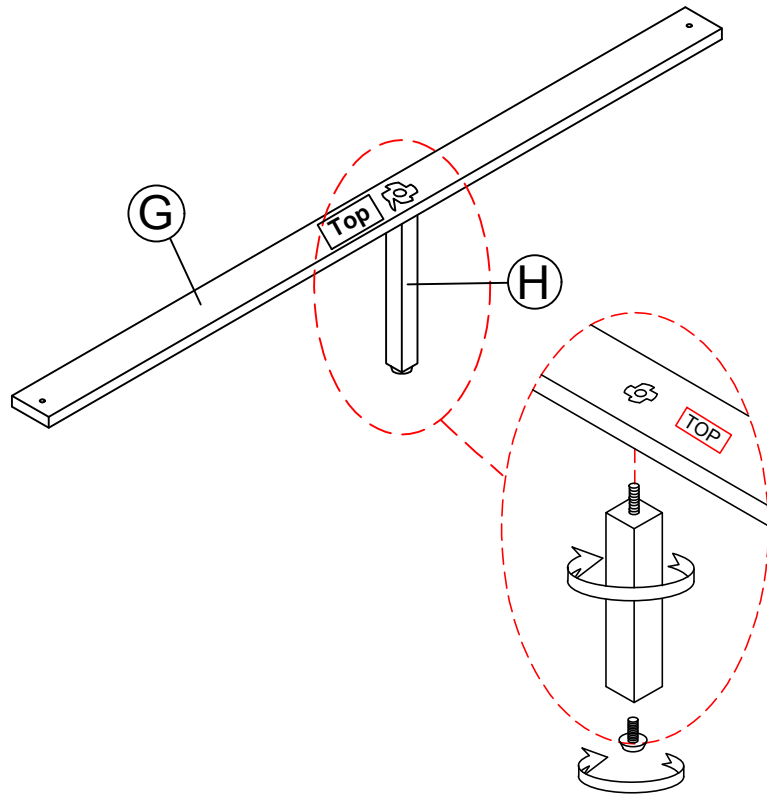

# STEP 6 COMPLETED

