

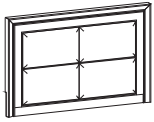









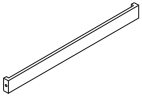

ASSEMBLY INSTRUCTIONS
INSTRUCCIONES

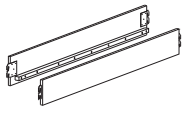
B1200-Q-HB: QUEEN HEADBOARD / CABECERA QUEEN
 B1200-Q-FB: QUEEN FOOTBOARD / PIECERA QUEEN
 B1200-KQ-RAIL: KING/QUEEN RAIL / RIEL PARA KING/QUEEN

BOX 1: BOX OF HEADBOARD			
No.	OUTLOOK	DESCRIPTION	QT.
1		HEADBOARD	1
2		HEADBOARD LEG (L/R)	2
3		STRETCHER	1

BOX 2: BOX OF FOOTBOARD			
No.	OUTLOOK	DESCRIPTION	QT.
4		FOOTBOARD	1
5		BED SLAT	4
6		SUPPORT LEG	4

BOX 3: BOX OF RAILS			
No.	OUTLOOK	DESCRIPTION	QT.
7		SIDE RAILS	2

HARDWARE LIST:				
No.	OUTLOOK	DESCRIPTION	SIZE	QT.
A		BOLT	Ø5/16" x 1-3/4"	8
B		LOCK WASHER	Ø5/16"	8
C		FLAT WASHER	Ø5/16"	8
D		ALLEN WRENCH	5mm	1
E		SCREW	#8x1-1/4"	8

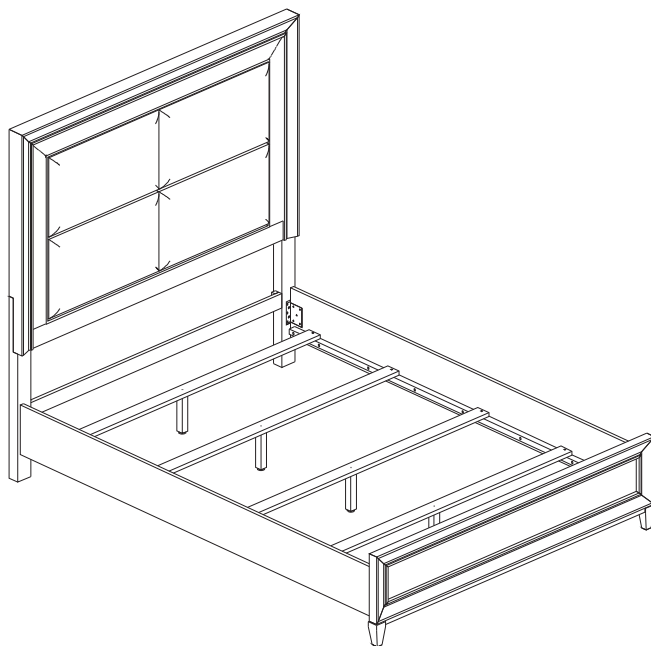

THE HARDWARE IS LOCATED
 IN THE PACKING ITEMS.

NOTE:
 DURING ASSEMBLY DO NOT FULLY
 TIGHTEN ANY HARDWARE UNTIL THE
 COMPLETE UNIT HAS BEEN ASSEMBLED.

ASSEMBLY INSTRUCTIONS
INSTRUCCIONES

B1200-Q-HB: QUEEN HEADBOARD / CABECERA QUEEN
B1200-Q-FB: QUEEN FOOTBOARD / PIECERA QUEEN
B1200-KQ-RAIL: KING/QUEEN RAIL / RIEL PARA KING/QUEEN

STEP 1

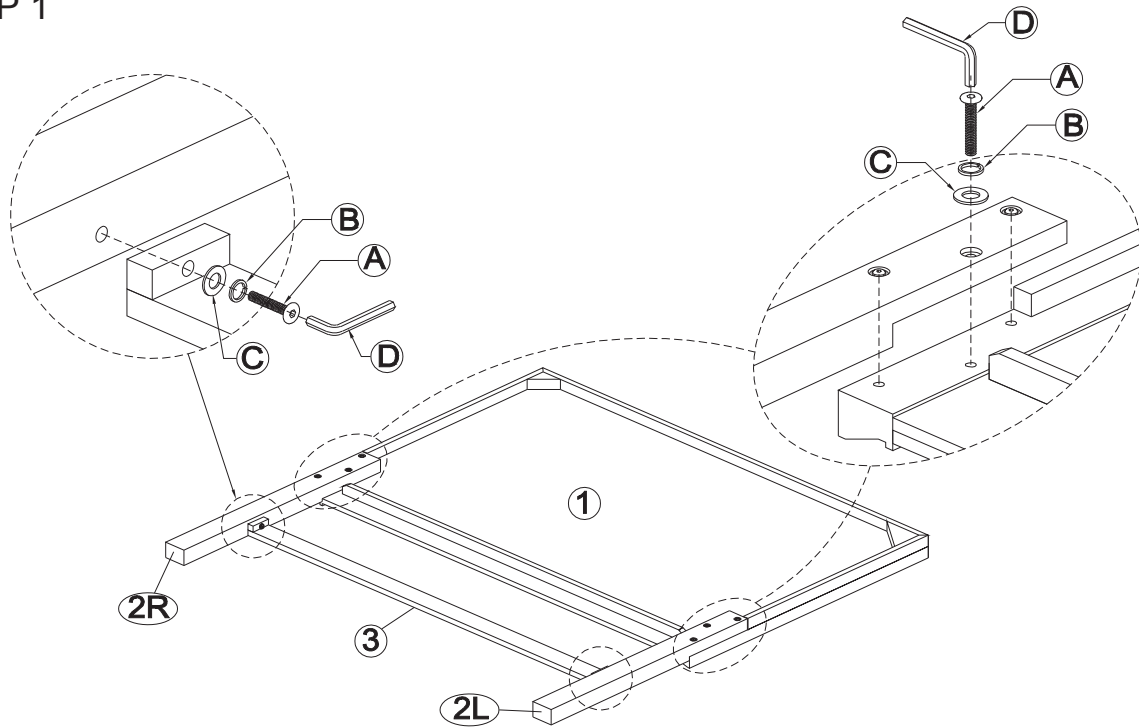

STEP 2

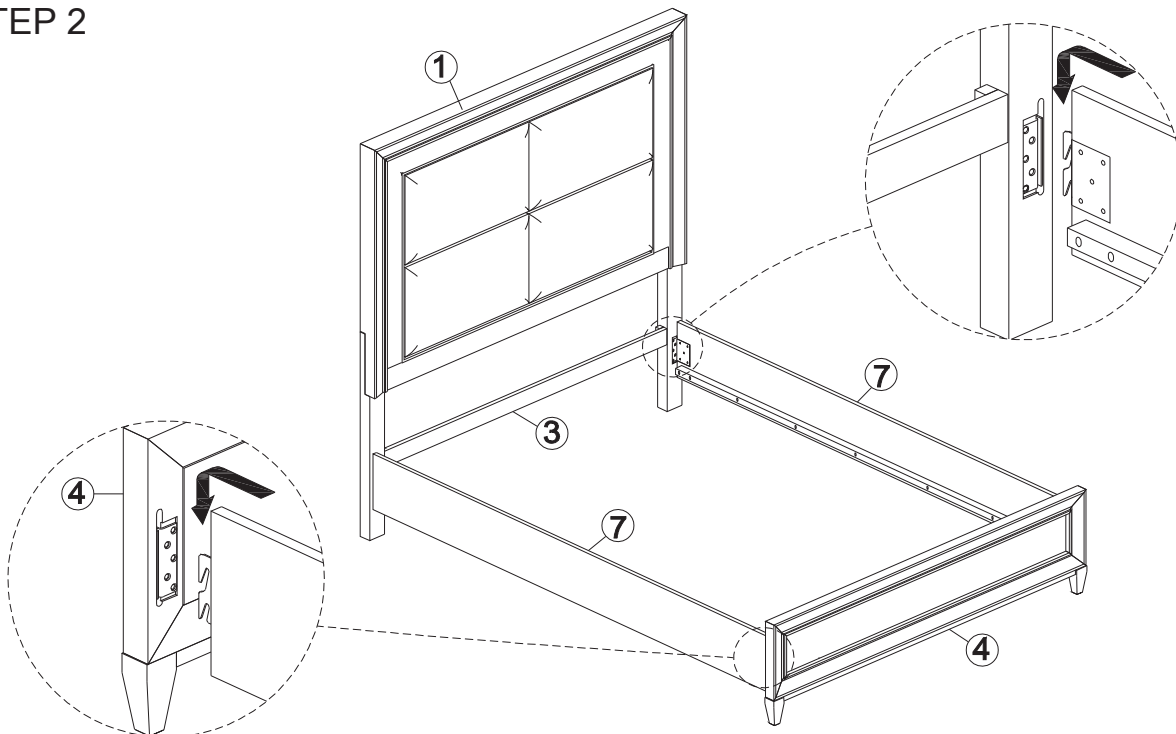

THE HARDWARE IS LOCATED
IN THE PACKING ITEMS.

NOTE:
DURING ASSEMBLY DO NOT FULLY
TIGHTEN ANY HARDWARE UNTIL THE
COMPLETE UNIT HAS BEEN ASSEMBLED.

ASSEMBLY INSTRUCTIONS
INSTRUCCIONES

B1200-Q-HB: QUEEN HEADBOARD / CABECERA QUEEN
B1200-Q-FB: QUEEN FOOTBOARD / PIECERA QUEEN
B1200-KQ-RAIL: KING/QUEEN RAIL / RIEL PARA KING/QUEEN

STEP 3

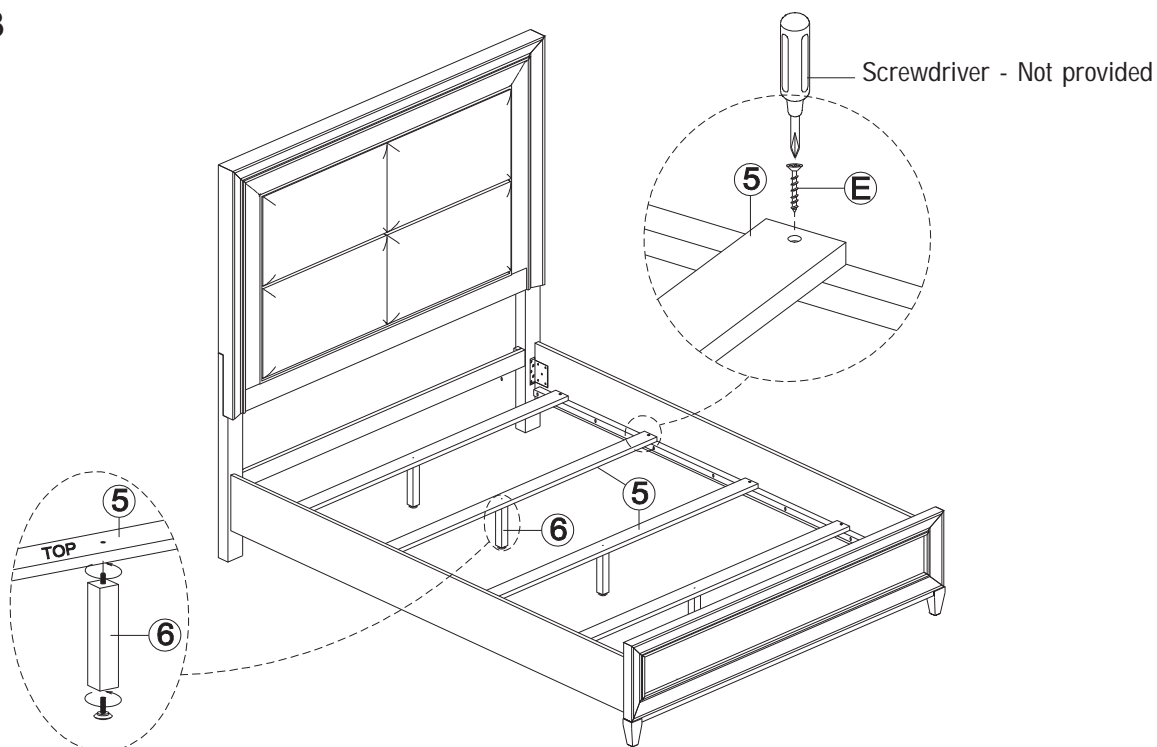

STEP 4

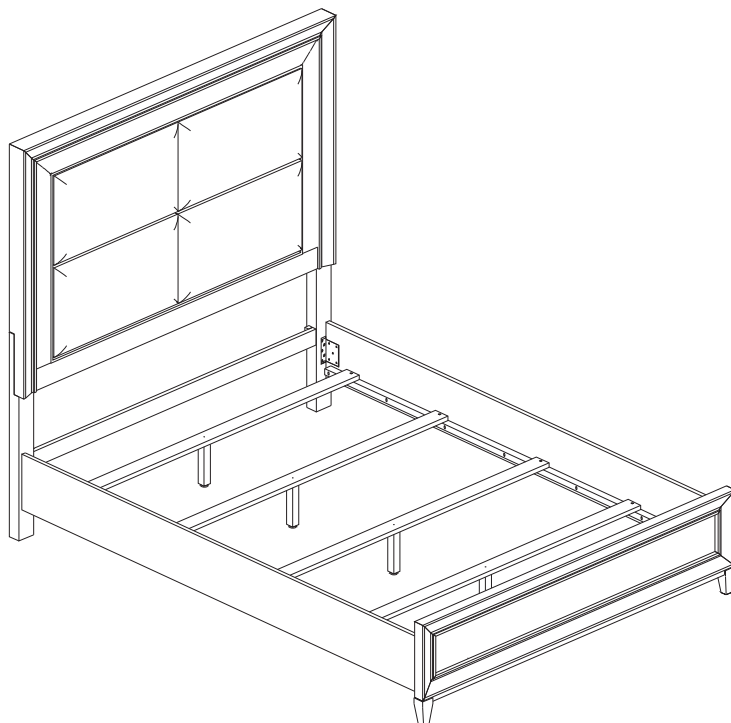

THE HARDWARE IS LOCATED
IN THE PACKING ITEMS.

NOTE:
DURING ASSEMBLY DO NOT FULLY
TIGHTEN ANY HARDWARE UNTIL THE
COMPLETE UNIT HAS BEEN ASSEMBLED.