







ASSEMBLY INSTRUCTION

CROWN MARK MODEL : B1120 KING BED

BOX 1 BOX OF HEADBOARD

NO	ITEM	Q'TY
1	Headboard 	1PC
2	Headboard Leg(L/R) 	2PCS
3	Stretcher 	1PC







BOX 2 BOX OF FOOTBOARD

NO	ITEM	Q'TY
4	Footboard 	1PC
5	Bed Slat 	4PCS
6	Support Leg 	8PCS

BOX 3 BOX OF RAILS

NO	ITEM	Q'TY
7	Side Rail (L/R) 	2PCS

BOX 1 HARDWARE LIST

NO	ITEM	Q'TY
A	φ5/16**18*2-3/8"L 	6PCS
B	φ5/16**18*1-3/4"L 	14PCS
C	φ5/16" 	20PCS
D	φ5/16" 	20PCS
E	φ5/16" 	1PC
F	9" X 3"+6/8" X 3MM 	2PCS
G	#8*1-3/8" 	8PCS

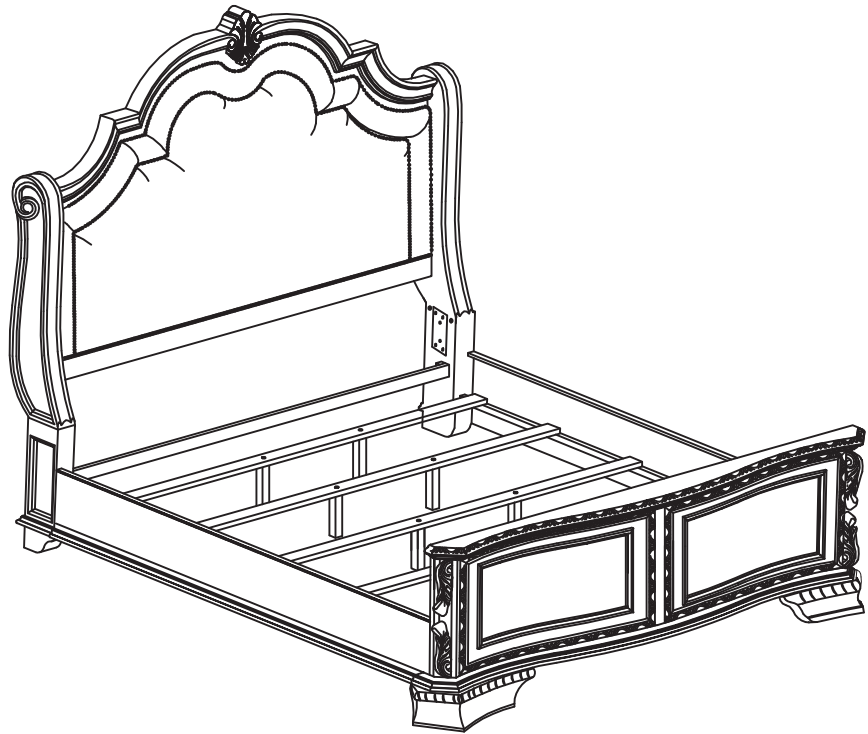

THE HARDWARE IS LOCATED
IN THE PACKING ITEMS.

NOTE:
DURING ASSEMBLY DO NOT FULLY
TIGHTEN ANY HARDWARE UNTIL THE
COMPLETE UNIT HAS BEEN ASSEMBLED.

NOTE: MUST TIGHTEN SCREWS PERIODICALLY WITH USE SCREWS WILL
BECOME LOOSE. CHECK TIGHTNESS OF ALL SCREWS EVERY 6-8 WEEKS.

ASSEMBLY INSTRUCTION

CROWN MARK MODEL : B1120 KING BED

Step 1 / Paso 1

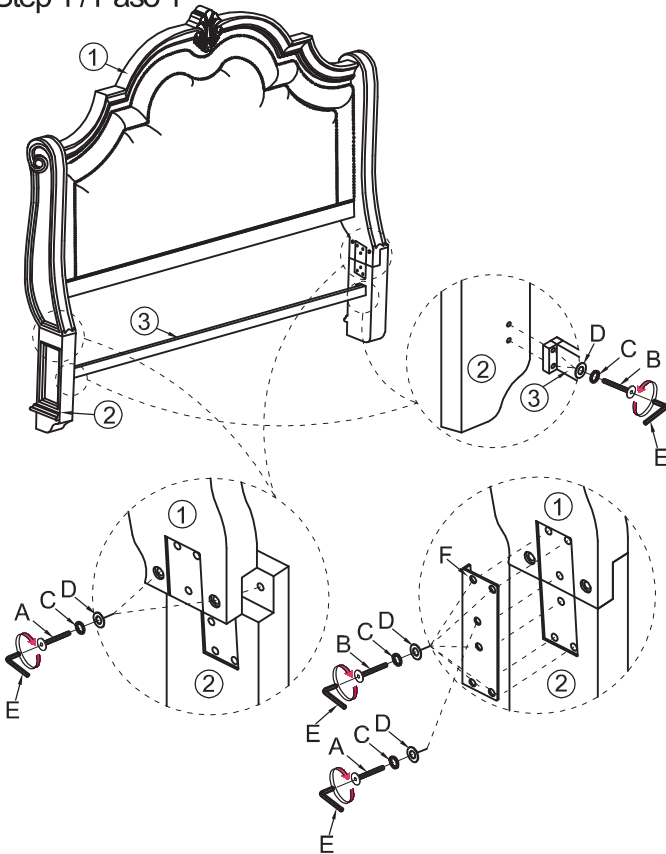

Step 2 / Paso 2

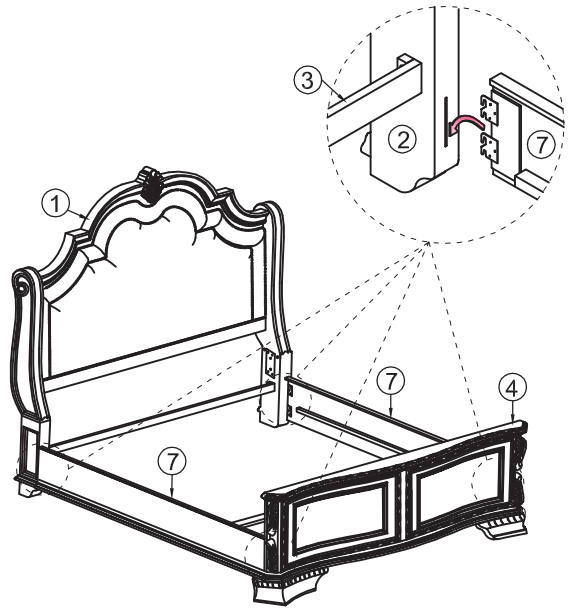

Step 3 / Paso 3

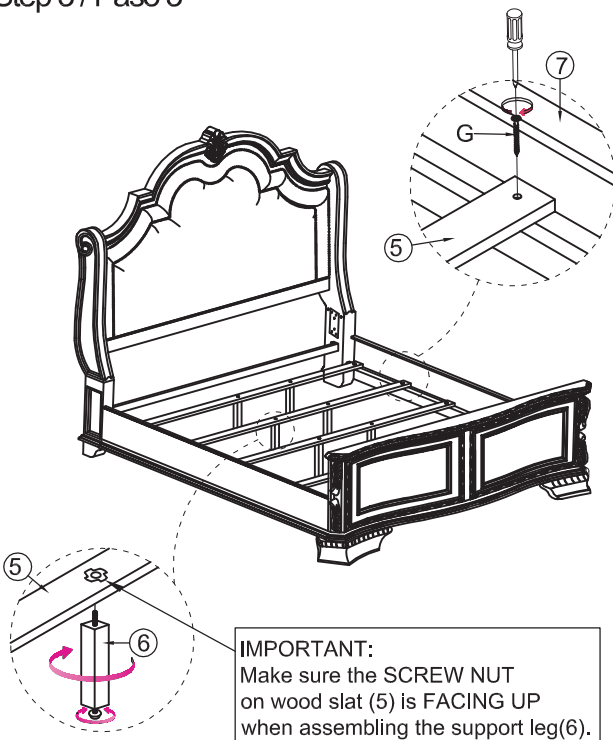

Step 4 / Paso 4
Complete

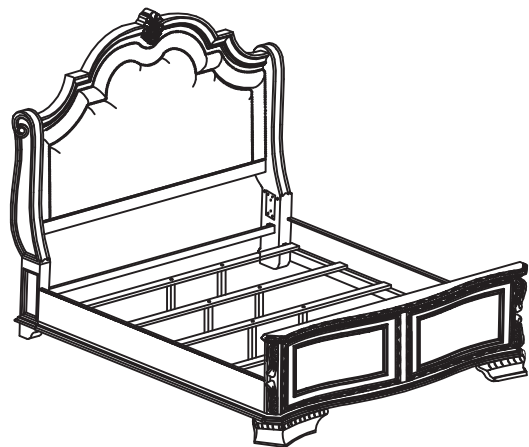

THE HARDWARE IS LOCATED
IN THE PACKING ITEMS.

NOTE:
DURING ASSEMBLY DO NOT FULLY
TIGHTEN ANY HARDWARE UNTIL THE
COMPLETE UNIT HAS BEEN ASSEMBLED.

NOTE: MUST TIGHTEN SCREWS PERIODICALLY WITH USE SCREWS WILL
BECOME LOOSE. CHECK TIGHTNESS OF ALL SCREWS EVERY 6-8 WEEKS.