













ASSEMBLY INSTRUCTIONS

ITEM NO: B2-201-26L/B2-201-30L

Don't tighten any Bolts until all Bolts on a step have been started

Thank you for purchasing this quality product. Be sure to check all packing material carefully for small parts, which may have come loose inside the carton during shipment. I identify and count all parts and compare with the HARDWARE LIST below.

NO	PARTS LIST		PARTS NO.	Q'TY	NO.	PARTS LIST		PARTS NO.	Q'TY
A		Bonded leather seat	B2201-26LP1	1	1		1/4" * 2"	B2201-26LP7	8
B		Top ring	B2201-26LP2	1	2		1/4" * 1 3/4"		6
C		Metal swivel	B2200-26LP3	1 pre-assy	3		1/4" * 1"		4
		Middle ring	B2201-26LP4		4		1/4" * 2 1/4"		4
D		Bottom ring	B2201-26LP5	1	5		8" * 1 1/2"		4
E		Leg	B2201-26LP6/ B2201-30LP6	4	6		Allen Wrench		1
F		Stool back	B2201-26LP8	1					

STEP 1

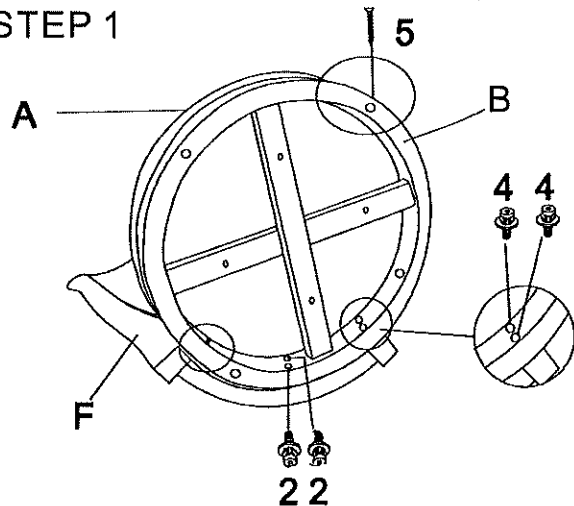

1. Attach the Bonded leather seat (A) to the Top RING (B), using Screws (5) to tighten, as shown.
2. Attach the stool back (F) to the (A+B) using Bolts (2) (4) to tighten, as shown.

STEP 2

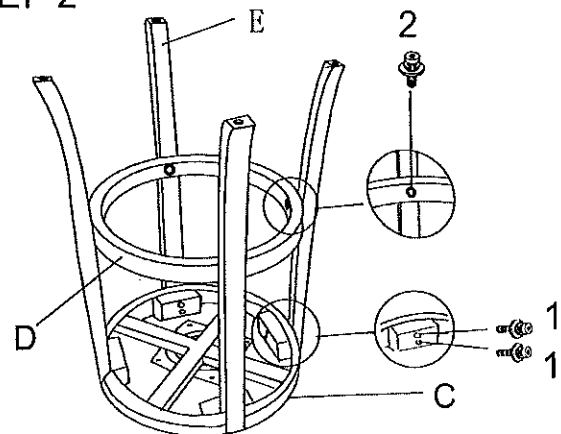

1. Attach the four Legs (E) to the Middle Ring (C), using Bolts (1) to tighten, as shown.
2. Attach the Bottom Ring (D) to the Legs, using Bolts (2) to tighten, as shown.

STEP 3

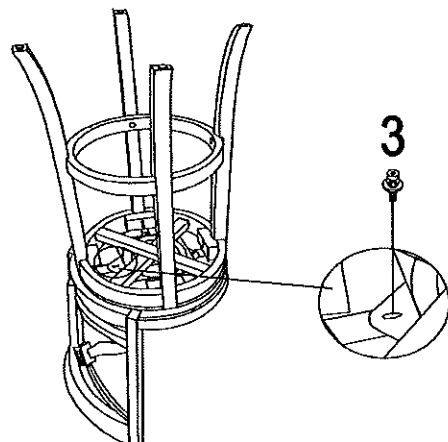

1. Upside down the Wooden Seat Back (STEP 1) and put it on a smooth and stable working stand.
2. Attach the Stool Base (STEP 2) to the Seat w/pre-assembly Seat Back (STEP 1), using Bolts (3) to tighten, as shown.

STEP 4

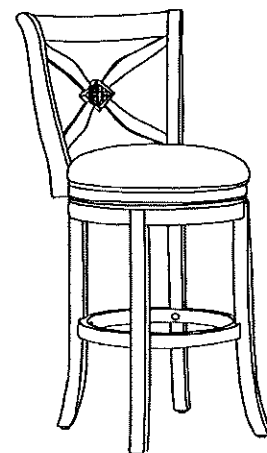

1. It's complete for using.