

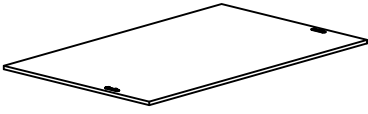

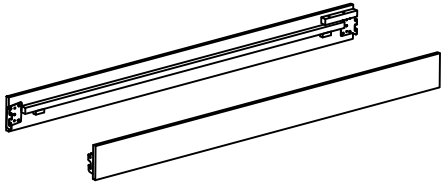

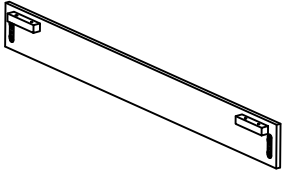

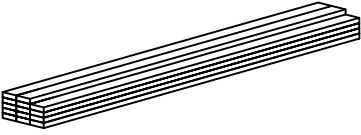

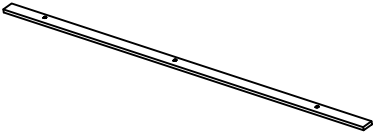





Product Assembly Instructions

LCPTBDQNBLK

PART LIST

 <p>A : HEADBOARD x1</p>	 <p>B : SIDERAIL (L&R) x2</p>	 <p>C : FOOTBOARD x1</p>
 <p>D : SLAT x14</p>	 <p>E : CENTER SLAT x1</p>	 <p>F : CENTER SLAT SUPPORT x3</p>
 <p>G : LEG x2</p>	 <p>H : LEG SUPPORT x2</p>	

HARDWARE LIST

 <p>I : JCBB SCREW M8 x 16mm x8</p>	 <p>J : ALLEN KEY M5 (SHORT) x1</p>	 <p>K : JCBC SCREW M6 x 50MM x3</p>
 <p>L : JCBC SCREW M6 x 40MM x12</p>	 <p>M : SPRING WASHER 1/4 " x15</p>	 <p>N : FLAT WASHER 1/4 " x12</p>
 <p>O : PAN HEAD SCREW M4 x 25mm x6</p>	 <p>P : ADJUSTER BASE GLIDE C99 x3</p>	 <p>Q : M4 ALLEN KEY (LONG) x1</p>

STEP 1

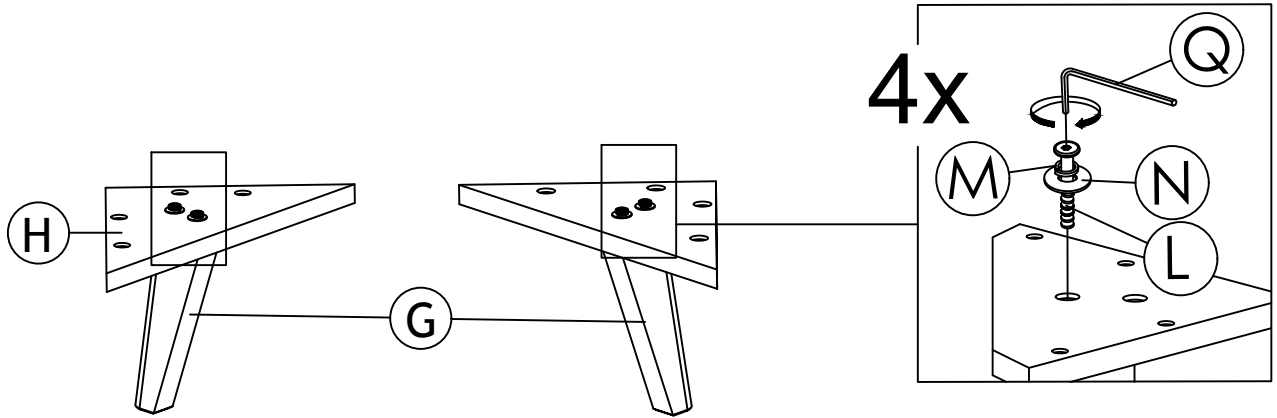

STEP 2

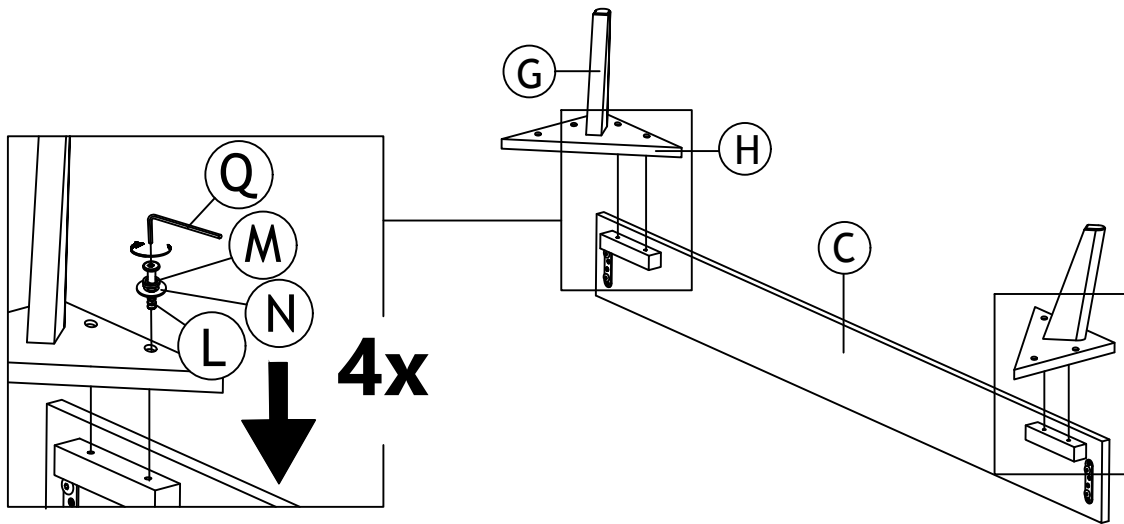

STEP 3

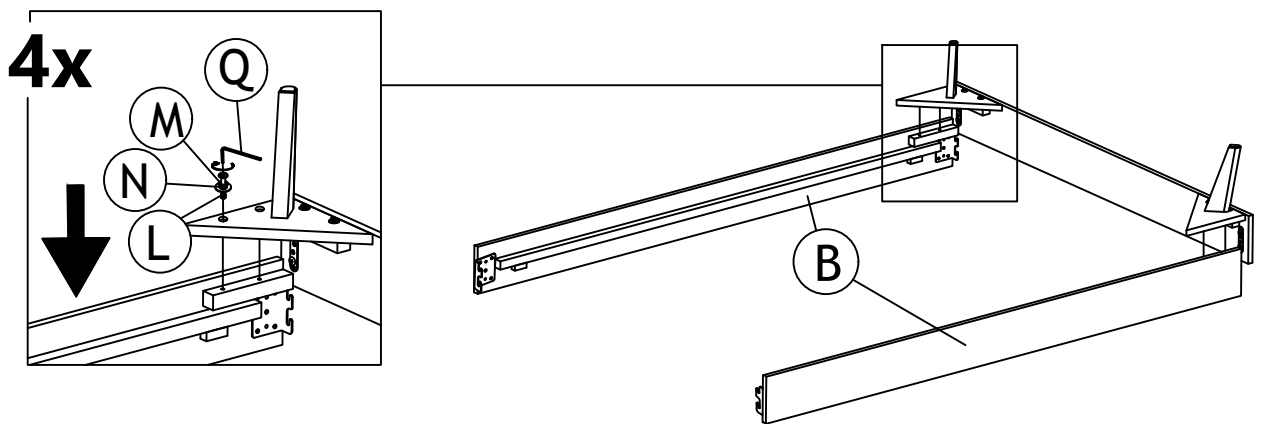

STEP 4

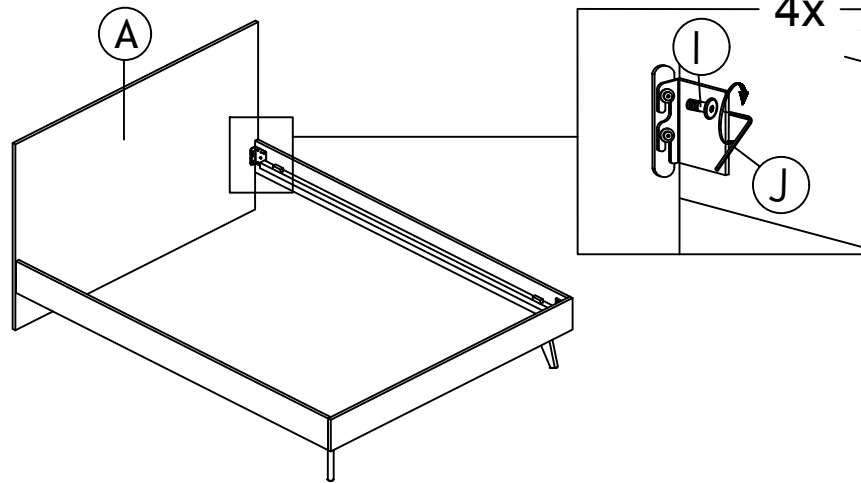

STEP 5

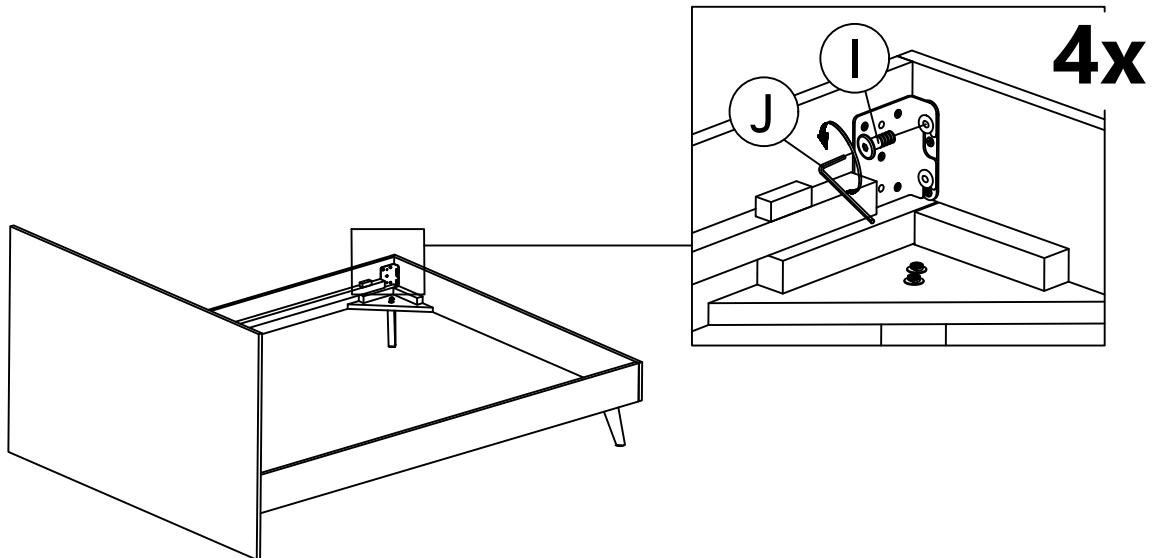

STEP 6

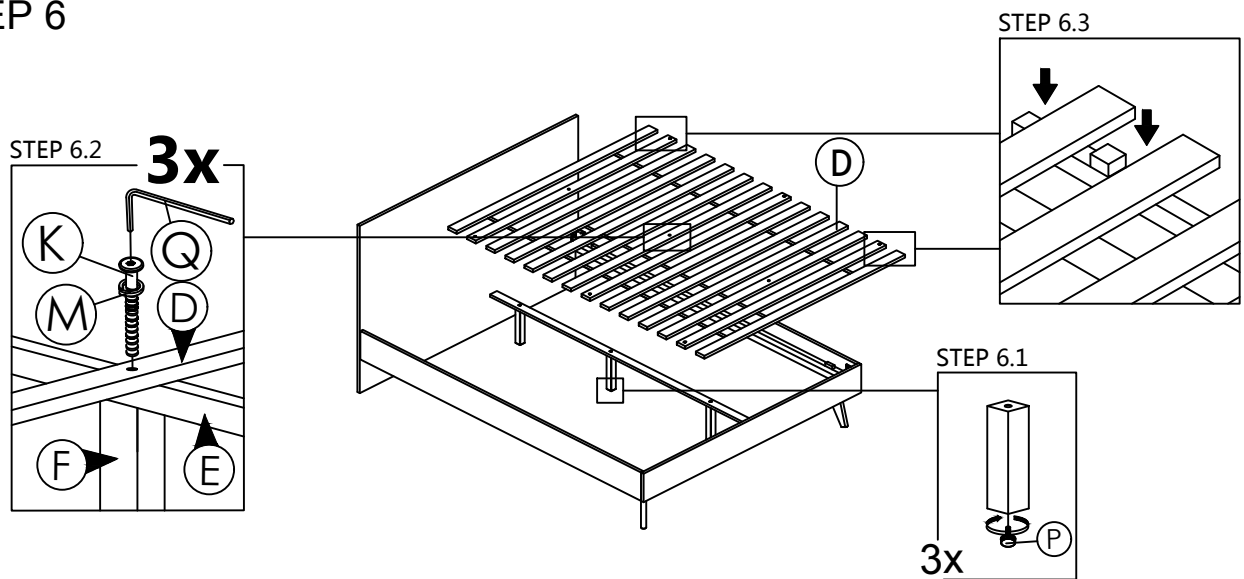

STEP 7

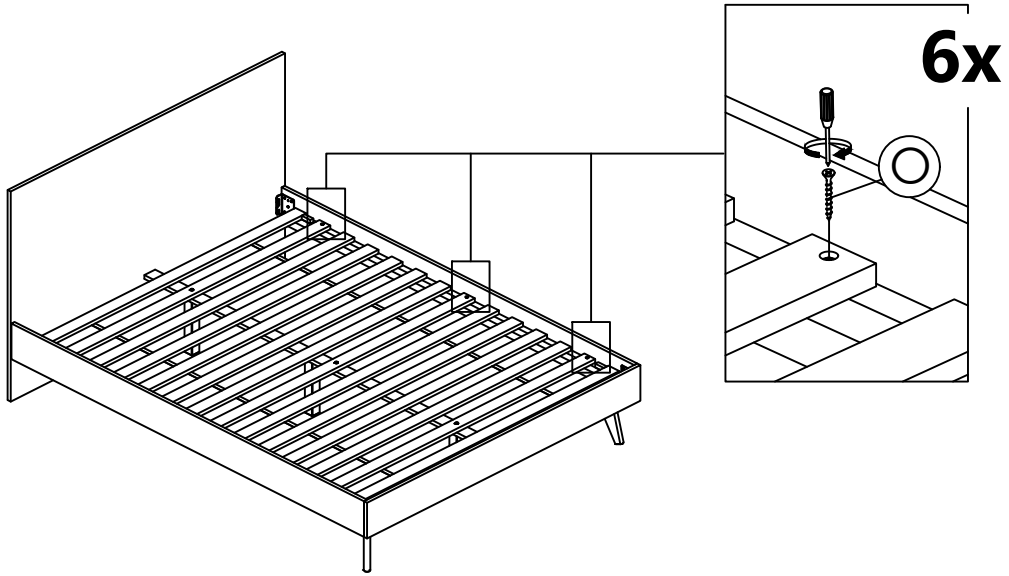

STEP 8

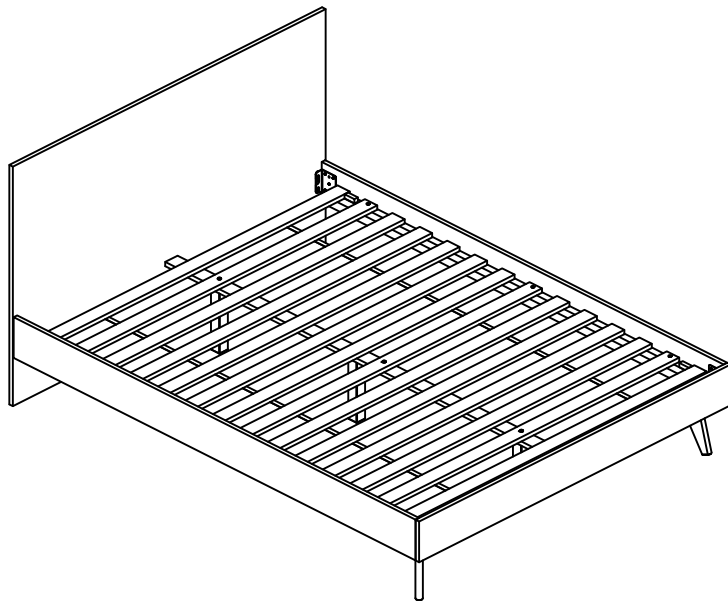

ASSEMBLY COMPLETED