

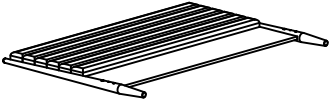

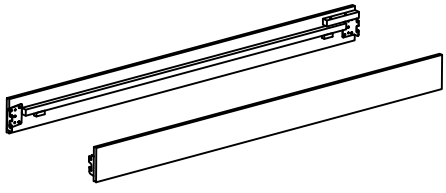

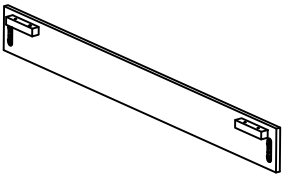

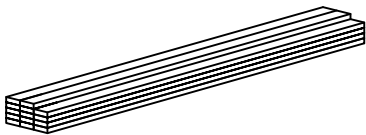

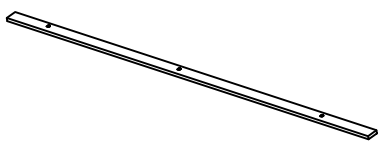











# Product Assembly Instructions

LCARBDKGBLK

## PART LIST

 <p>A : HEADBOARD x1</p>	 <p>B : SIDERAIL (L&amp;R) x2</p>	 <p>C : FOOTBOARD x1</p>
 <p>D : SLAT x14</p>	 <p>E : CENTER SLAT x1</p>	 <p>F : CENTER SLAT SUPPORT x3</p>
 <p>G : LEG x2</p>	 <p>H : LEG SUPPORT x2</p>	

## HARDWARE LIST

 <p>I : JCBB SCREW M8 x 16mm x4</p>	 <p>J : JCBC SCREW M6 x 50MM x3</p>	 <p>K : JCBC SCREW M6 x 35MM x10</p>
 <p>L : SPRING WASHER 1/4 " x13</p>	 <p>M : FLAT WASHER 1/4 " x10</p>	 <p>N : PAN HEAD SCREW M4 x 25mm x6</p>
 <p>O : ADJUSTER BASE GLIDE C99 x3</p>	 <p>P : WOOD DOWEL Ø8x30mm x2</p>	 <p>Q : BOLT 70mm x4</p>
 <p>R : HEX NUT M6 x4</p>	 <p>S : PLASTIC WASHER x4</p>	 <p>T : M4 ALLEN KEY (LONG) x1</p>
 <p>U : M5 ALLEN KEY (SHORT) x1</p>	 <p>V : SPANNER x1</p>	

STEP 1

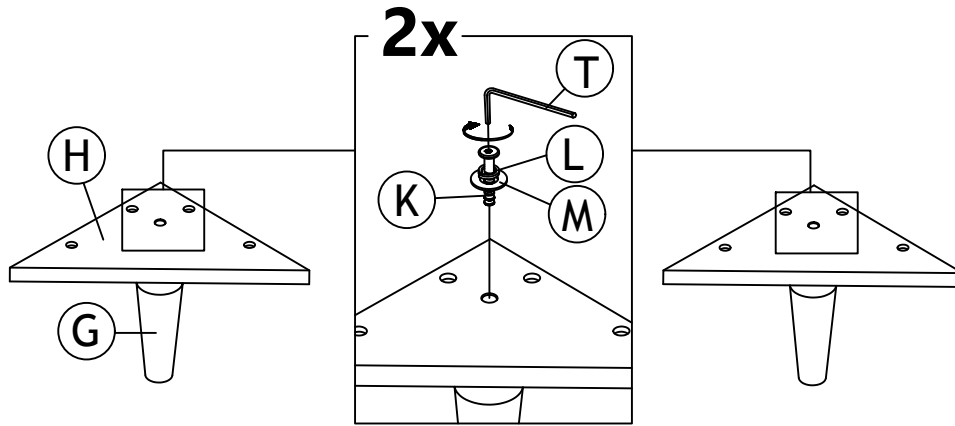

STEP 2

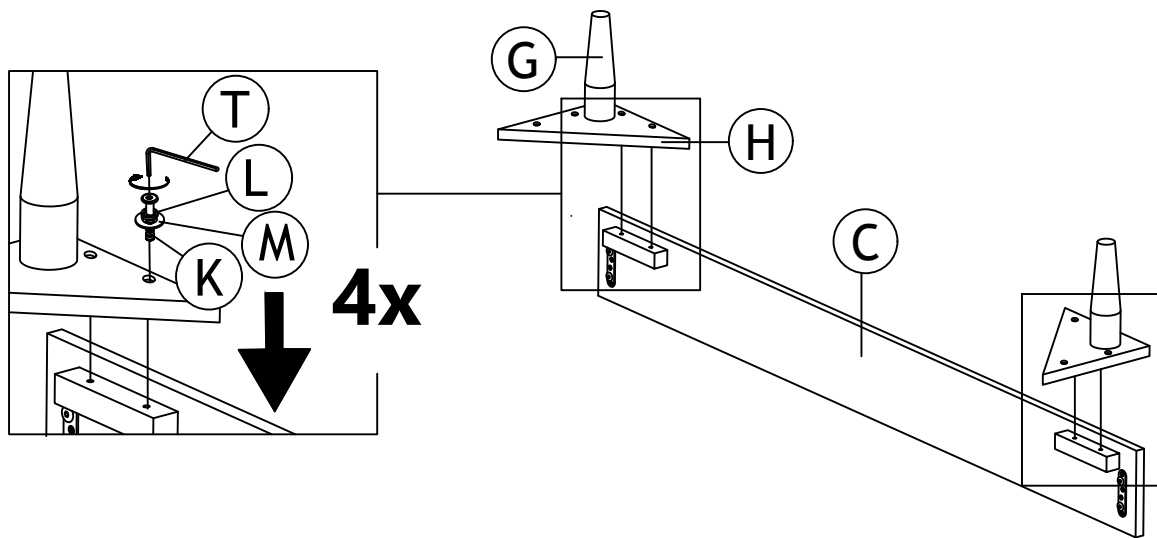

STEP 3

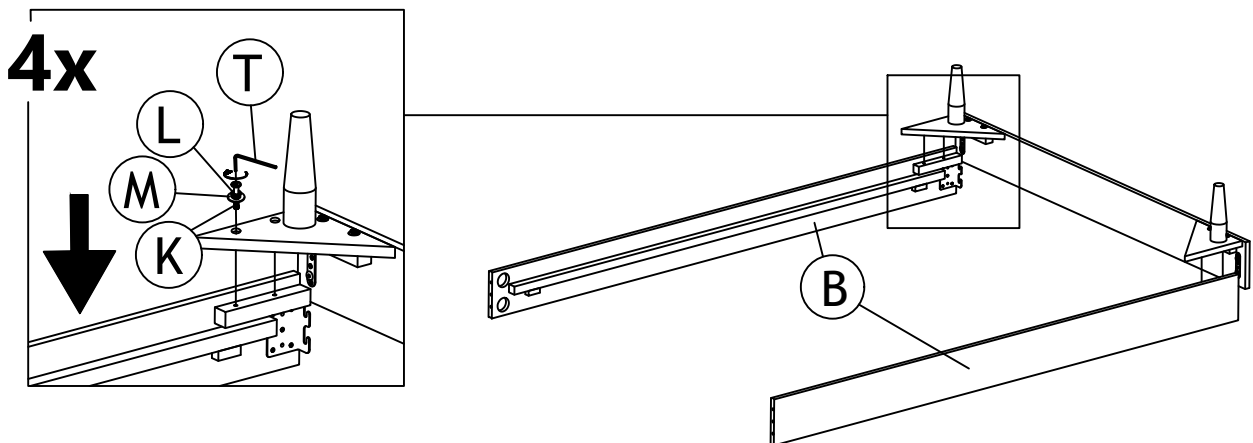

### STEP 4

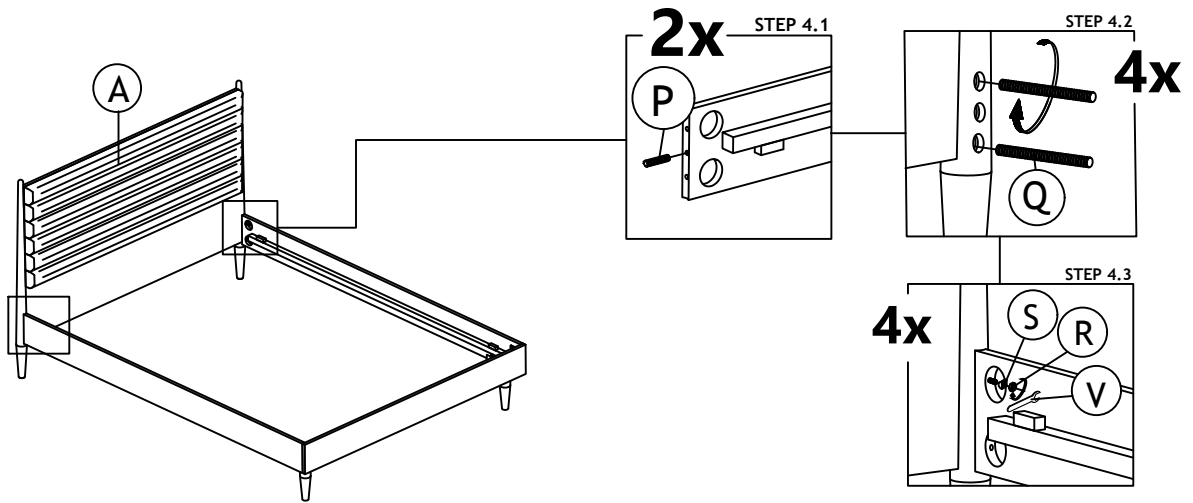

### STEP 5

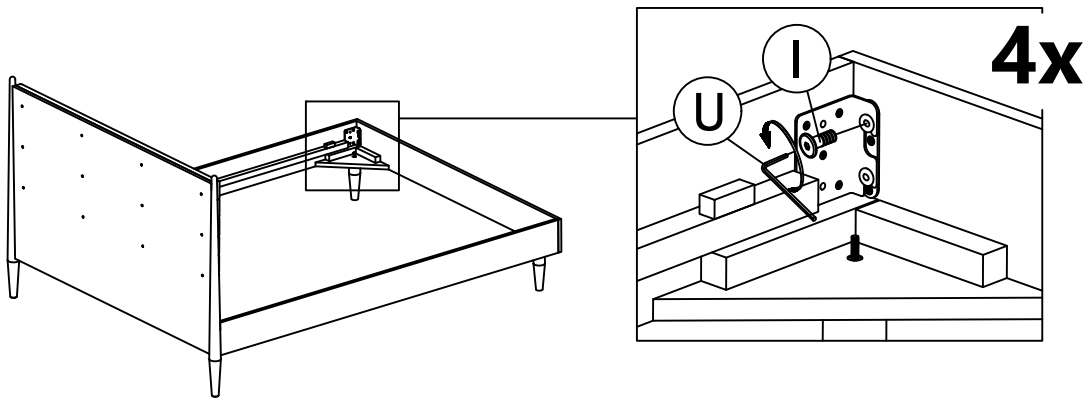

### STEP 6

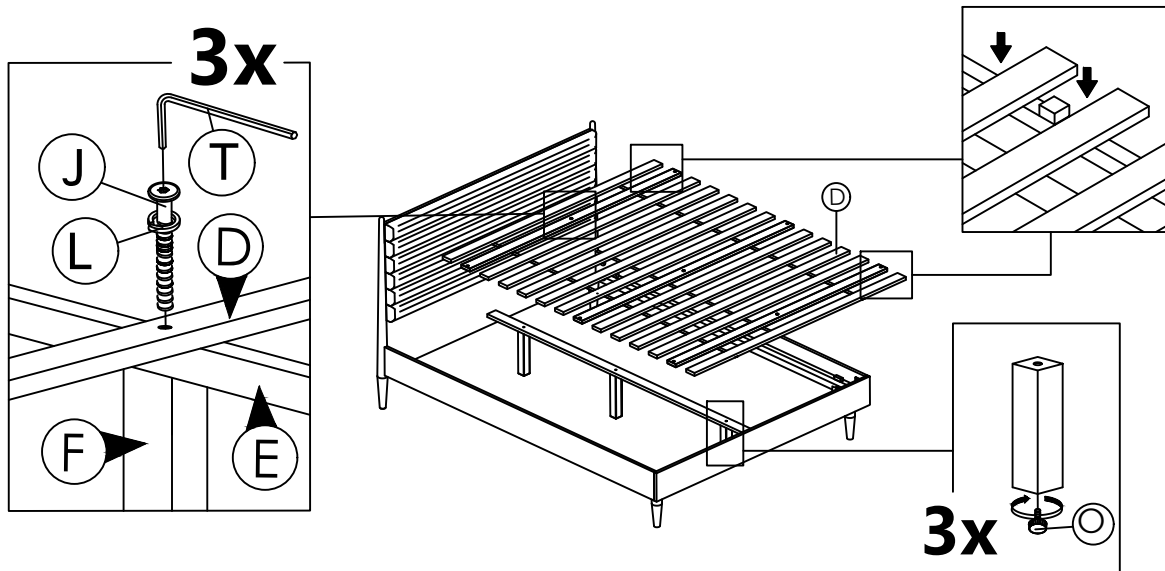

STEP 7

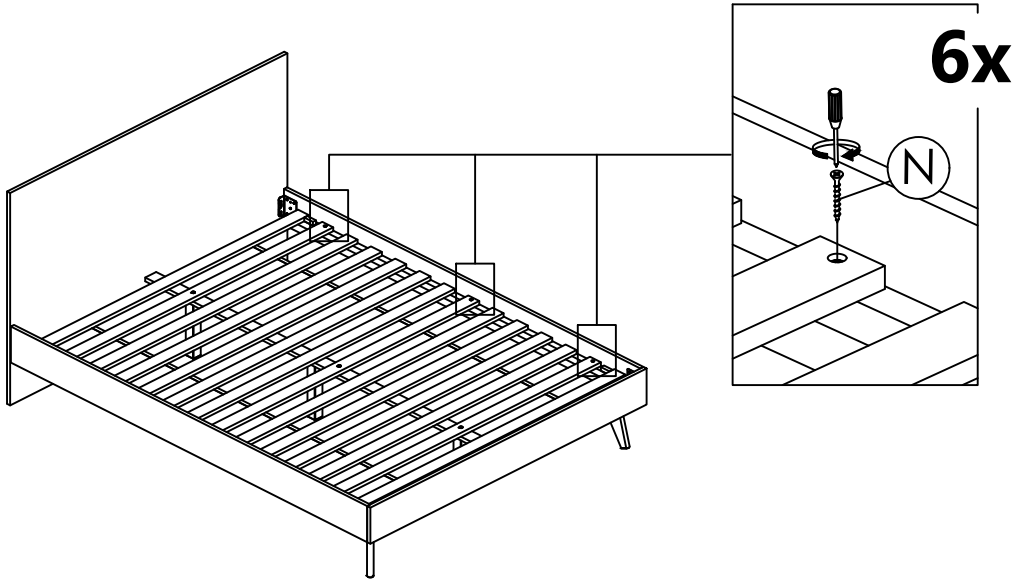

STEP 8

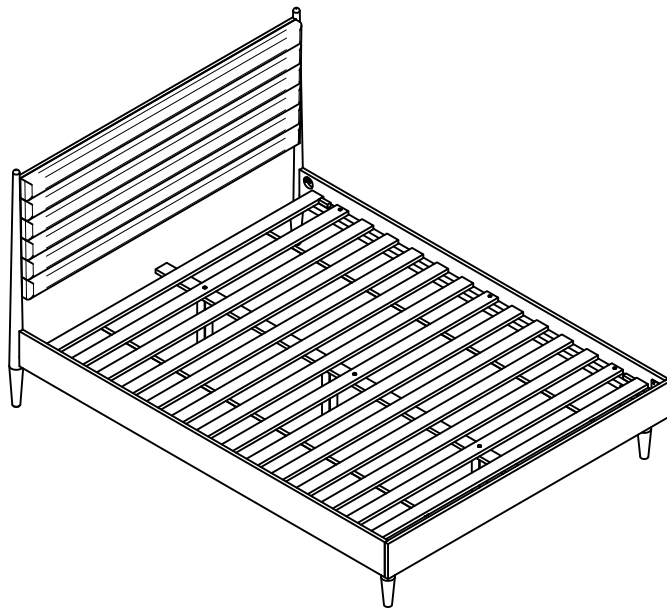

ASSEMBLY COMPLETED