

## ASSEMBLY INSTRUCTIONS

Before assembling your headboard, please read through these instructions carefully and familiarize yourself with the different parts.

**ATTENTION!** If you receive a damaged or defective item, please contact afifurnishings at customerservice@afifurnishings.com or 1-800-955-3726



### PARTS LIST

- 1 HEADBOARD PANEL 1 PC
- 2 LEFT LEG 1 PC
- 3 RIGHT LEG 1 PC
- 4 WOOD DOWELS 4 PCS  
(Factory Installed)

Instructions apply for bed sizes  
TWIN > FULL

### HARDWARE

- A** JCB M6 X 110mm (4 3/8") - 4 pcs  
Spare - 1 pc
- B** Barrel nut - 4 pcs  
Spare - 1 pc
- F** Allen wrench - 1 pc  
Spare - 1 pc
- HARDWARE FOR METAL BED FRAME**
- C** JCB M6 X 25mm (1") - 4 pcs  
Spare - 1 pc
- D** Flat washer - 4 pcs  
Spare - 1 pc
- E** Split washer - 4 pcs  
Spare - 1 pc

NOTE: WE INCLUDE SPARE HARDWARE IN CASE DAMAGE OCCURS DURING ASSEMBLY.

### Step 1

Attach the legs (2) and (3) to headboard panel (1), using JCB (A) and barrel nut (B). Tighten with the Allen wrench (F).

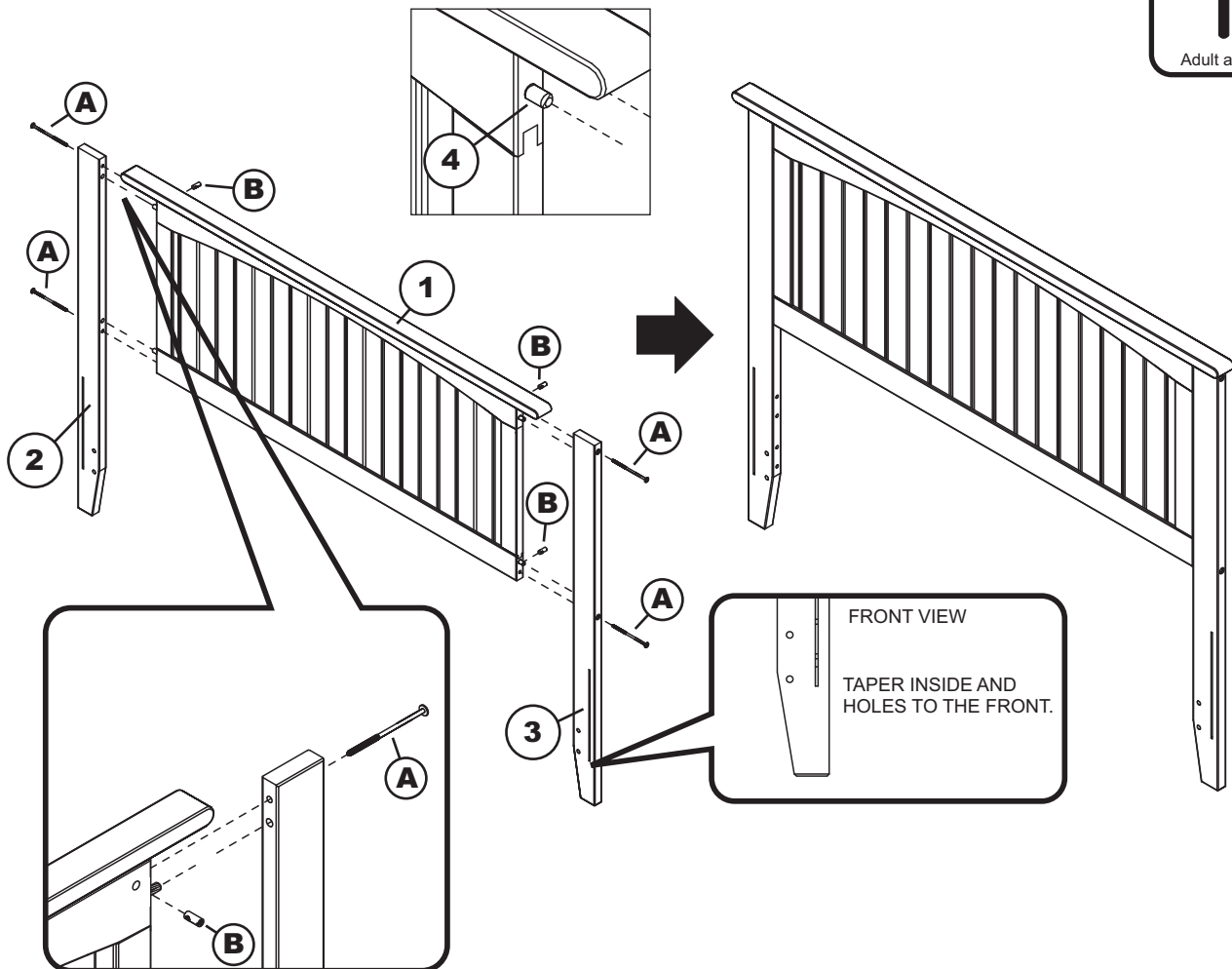

| CODE   | ITEM     | ITEM     |
|--------|----------|----------|
| HB-NKT | R-28282X | R-28283X |

**PO :**

If you purchased a wood headboard to attach to metal bed frame, please refer to page 2.

**ASSEMBLY INSTRUCTIONS**

Before assembling your bed, please read through these instructions carefully and familiarize yourself with the different parts.

Instructions apply for bed sizes  
**Twin > Full**



Metal bed frames are sold separately from wood headboards. The hardware shown on this page is supplied with your wood headboard for attaching the bed frame to the headboard. The metal bed frame is supplied with its own assembly instructions and hardware.

**Step 1** Attach the headboard assembly to the metal frame using JCB (C), flat washer (D), and split washer (E) then tighten with Allen wrench (F), as shown below.

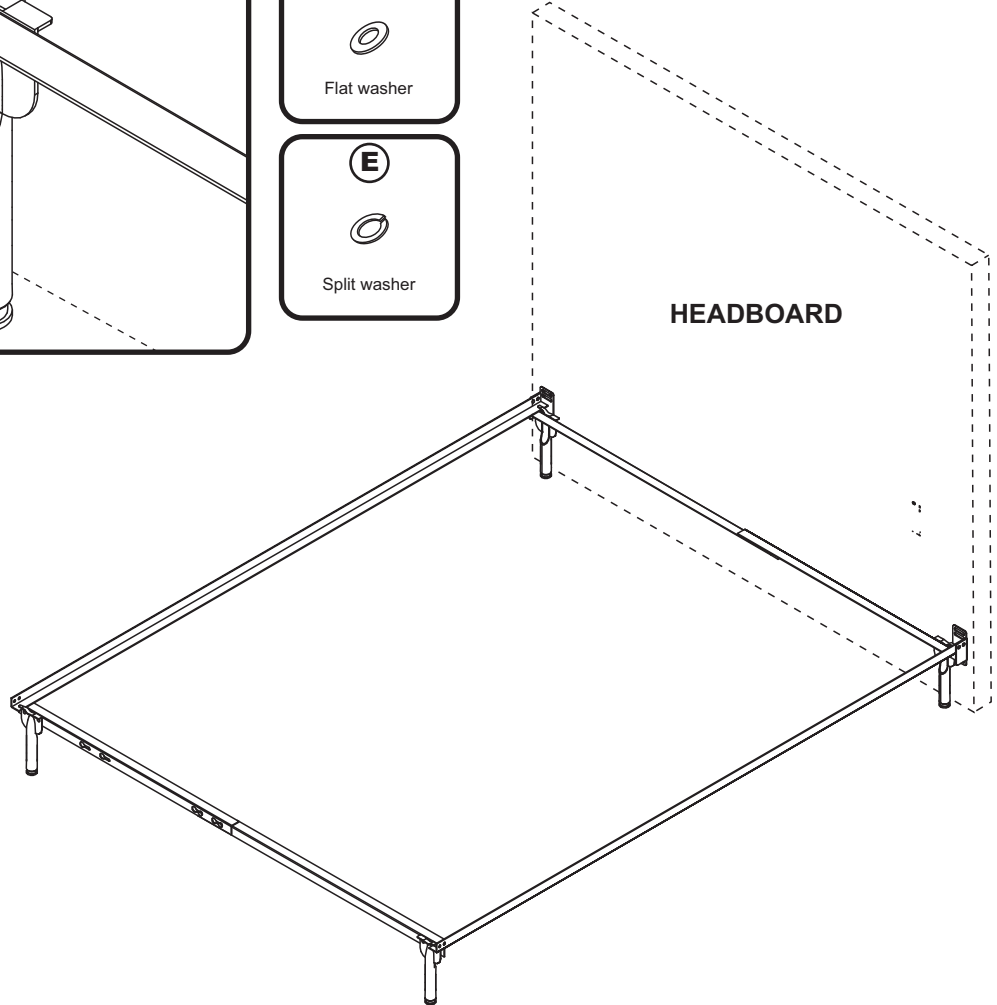
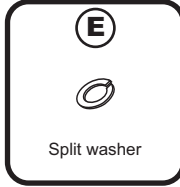
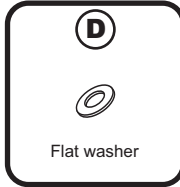
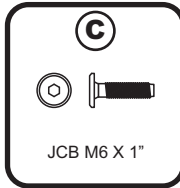
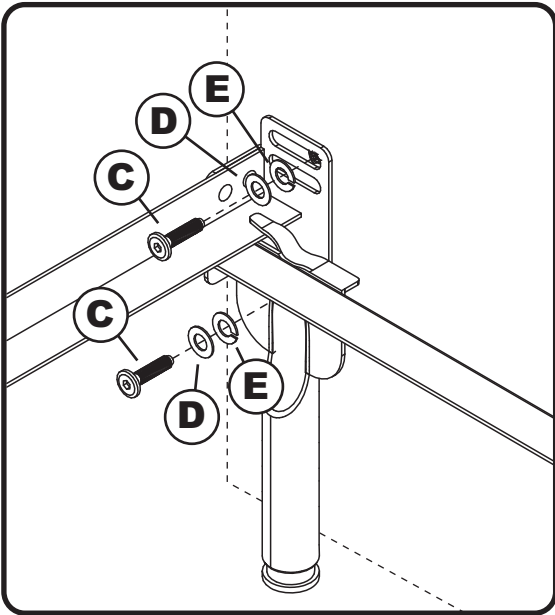

**Congratulations!**

Your bed is now ready for use.  
To ensure lasting safety, we recommend that you periodically check that all screws are tight and all parts are secure.