

ASSEMBLY INSTRUCTIONS

Before assembling your headboard, please read through these instructions carefully and familiarize yourself with the different parts.

ATTENTION! If you receive a damaged or defective item, please contact [afifurnishings.com](mailto:customerservice@afifurnishings.com) at customerservice@afifurnishings.com or 1-800-955-3726



PARTS LIST

- ① HEADBOARD PANEL 2 PCS
- ② LEFT POST 1 PC
- ③ RIGHT POST 1 PC
- ④ HB TOP RAIL 1 PC
- ⑤ MID RAIL 1 PC
- ⑥ HB BOTTOM RAIL 1 PC
- ⑦ FOOTBOARD PANEL 1 PC
- ⑧ LEFT LEG 1 PC
- ⑨ RIGHT LEG 1 PC
- ⑩ FB TOP RAIL 1 PC
- ⑪ FB BOTTOM RAIL 1 PC

Instructions apply for bed sizes
FULL > QUEEN

HARDWARE

- ① JCB M6 X 110mm - 8 pcs
Spare - 1 pc
- ② Barrel Nut - 8 pcs
Spare - 1 pc
- ③ JCB M8 X 15mm (5/8") - 8 pcs
Assembly headboard and footboard to side rails
- ④ Wood Dowel - 16 pcs
Spare - 1 pc
- ⑤ Allen wrench - 1pc
Spare - 1pc
- ⑥ Allen wrench M6 - 1pc

NOTE: WE INCLUDE SPARE HARDWARE IN CASE DAMAGE OCCURS DURING ASSEMBLY.

Step 1

Insert all wooden dowels (D) into the locator holes on (4)(5)(6)(10) and(11) as shown below.

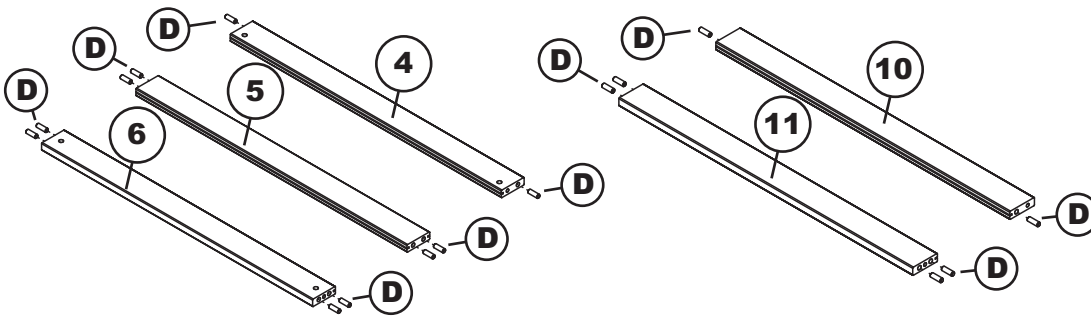

Adult assembly

④



Wood Dowel

Step 2

Lay the left post (2) bracket face down on smooth surface. Connect HB top rail (4), mid rail (5) and HB bottom rail (6) as shown below, using JCB M6 X 110mm (A) and barrel nut (B). Tighten with the Allen wrench (E).

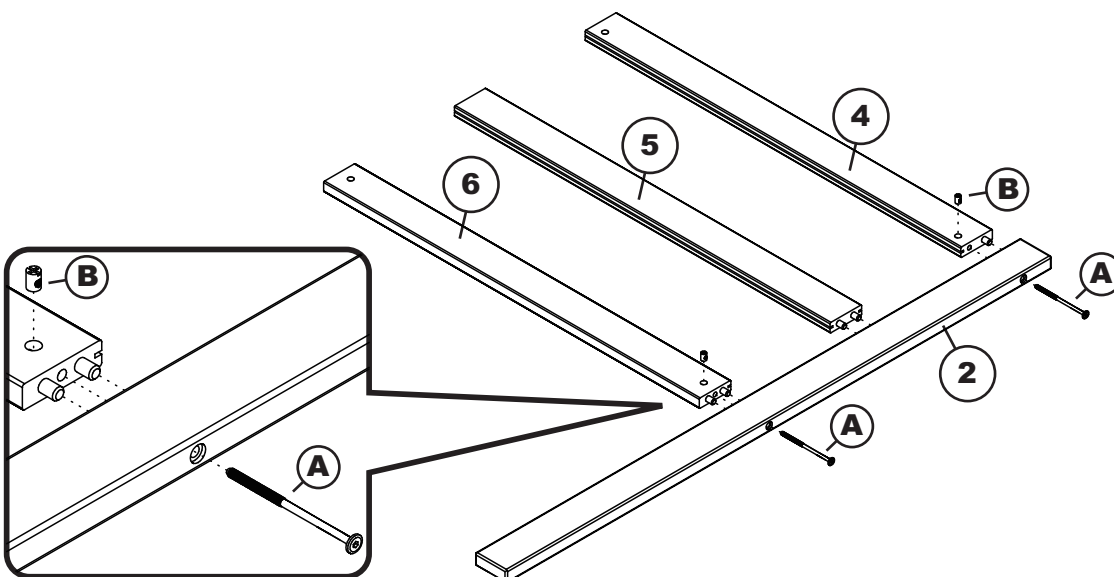

Adult assembly

①

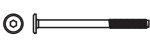

JCB M6 X 110mm

②



Barrel Nut

PO:

CODE	ITEM	ITEM
HBFB-ISL-NOHO	G-12913X	G-12914X

Step 3

Guide the headboard panel (1) in carefully so that it won't jump out of its grooves. Be sure it fits fully into the groove at the end (in the post) before fitting the other post

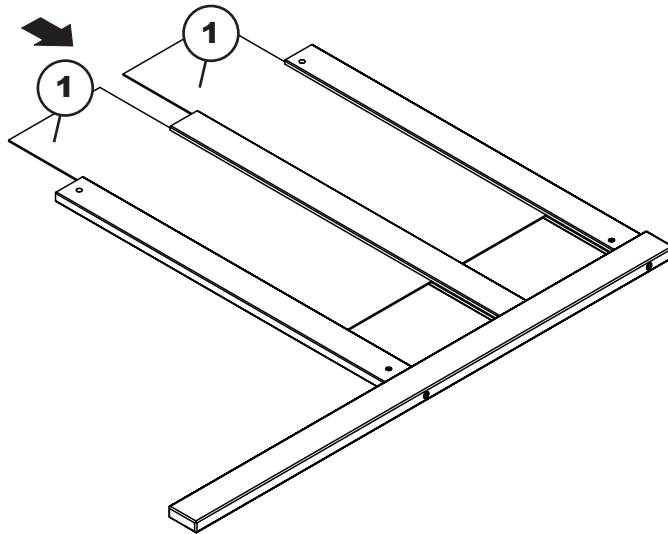

Step 4

Attach the right post (3) to headboard assembly as shown below, using JCB M6 X 110mm (A) and barrel nut (B). Tighten with Allen wrench (E)

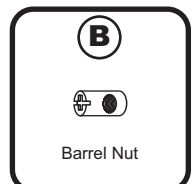
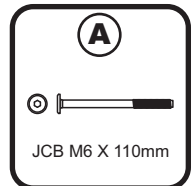
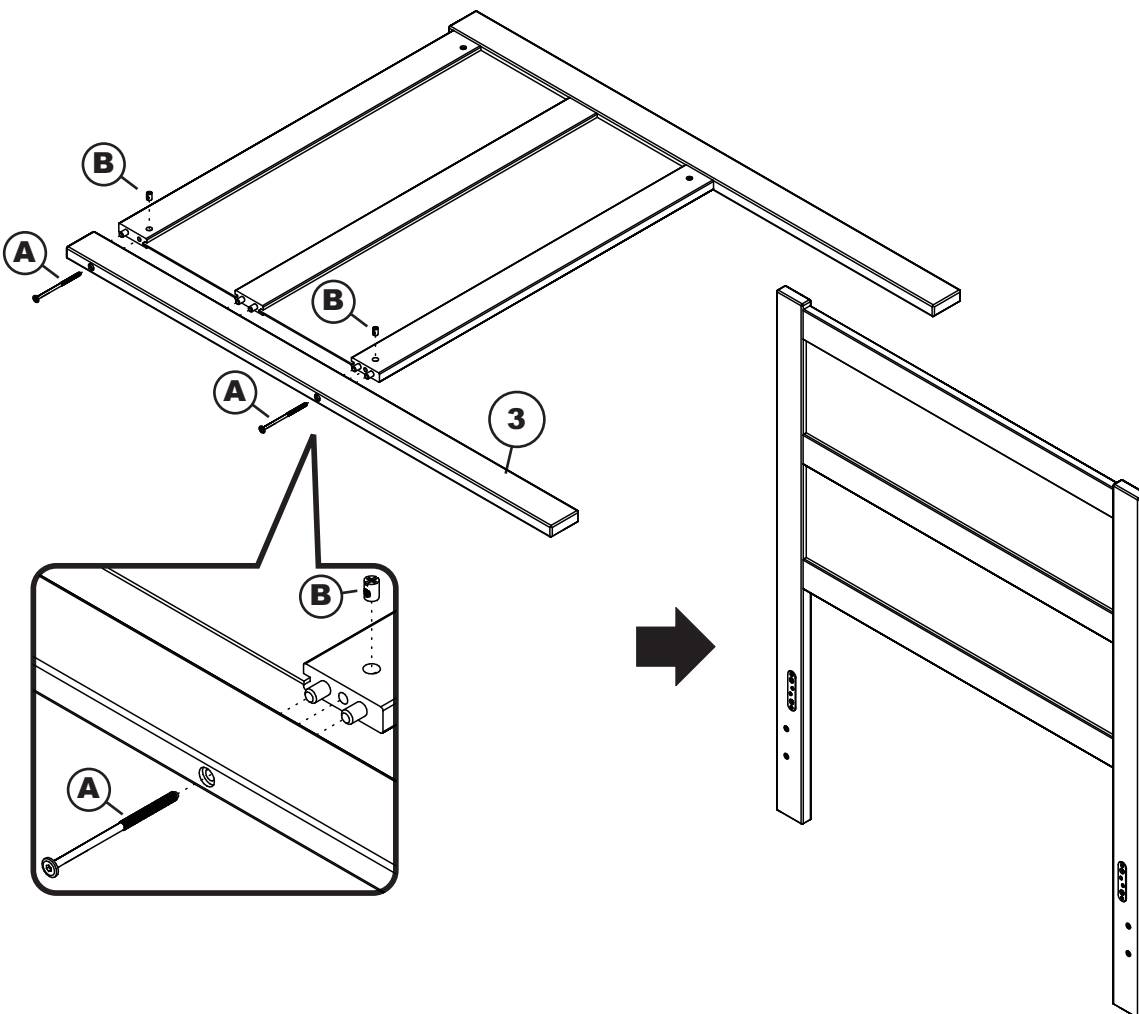

Step 5

Lay the left leg (8) bracket face up on smooth surface. Connect FB top rail (10) and FB bottom rail (11) as shown below, using JCB M6 X 110mm (A) and barrel nut (B). Tighten with the Allen wrench (E).

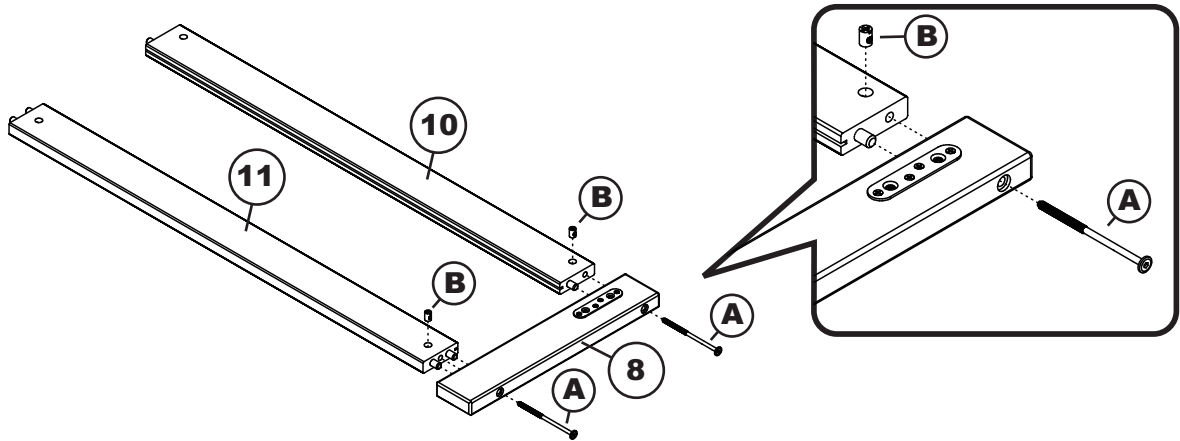

Step 6

Guide the footboard panel (7) in carefully so that it won't jump out of its grooves. Be sure it fits fully into the groove at the end (in the leg) before fitting the other leg.

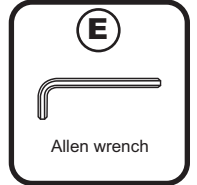
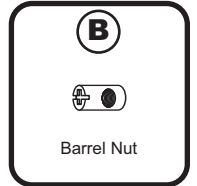
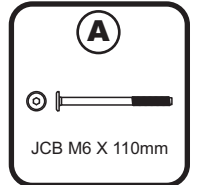
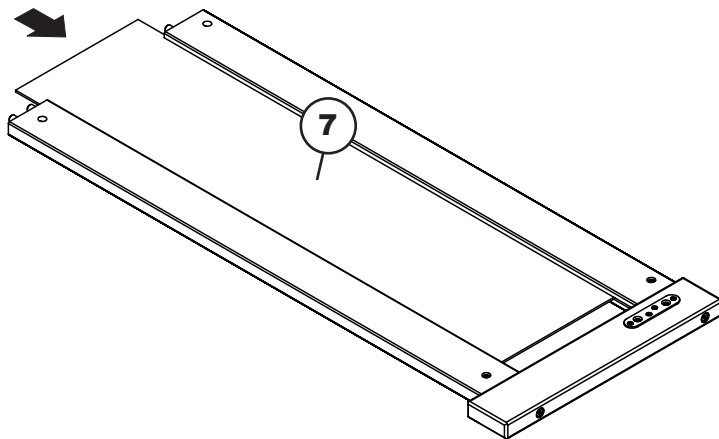

Step 7

Attach the right leg (9) to footboard assembly as shown below, using JCB M6 X 110mm (A) and barrel nut (B). Tighten with Allen wrench (E)

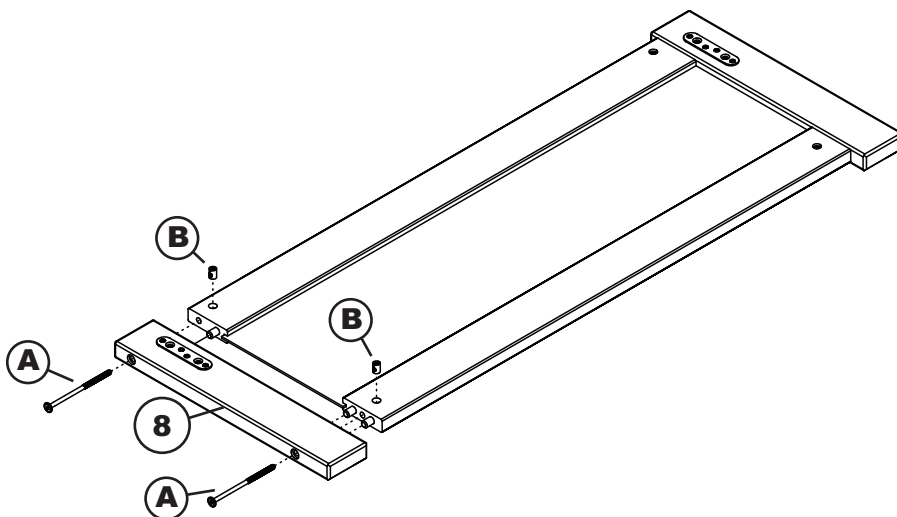

- 01 HARDWARE
 - 02 HEADBOARD
 - 03 FOOTBOARD
- BOX 1

- 01 HARDWARE
 - 04 SIDE RAILS
 - 05 SLAT KIT
- BOX 2

Step 1

Attach the side rails (04) to the headboard (02) and footboard (03) using JCB M8 X 15mm (C). Tighten with Allen wrench M6 (F).

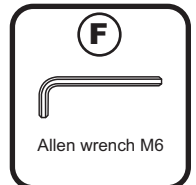
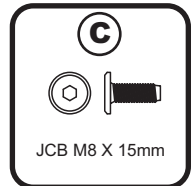
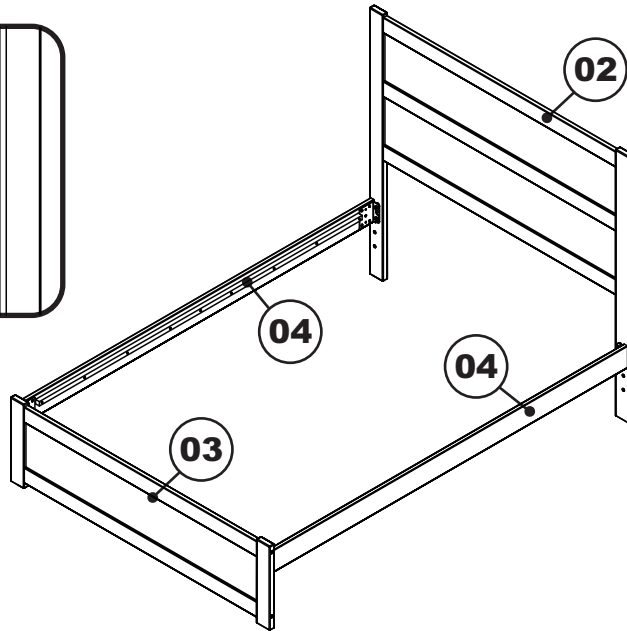
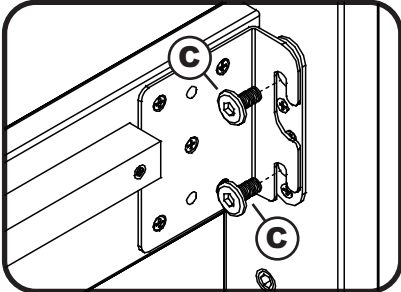

Step 2

Attach slat kit (05) onto the bed using wood screws. Tighten with Phillips head screw driver. (customer supplied) For assembly of slat kit, follow the assembly instructions included with bed frame.

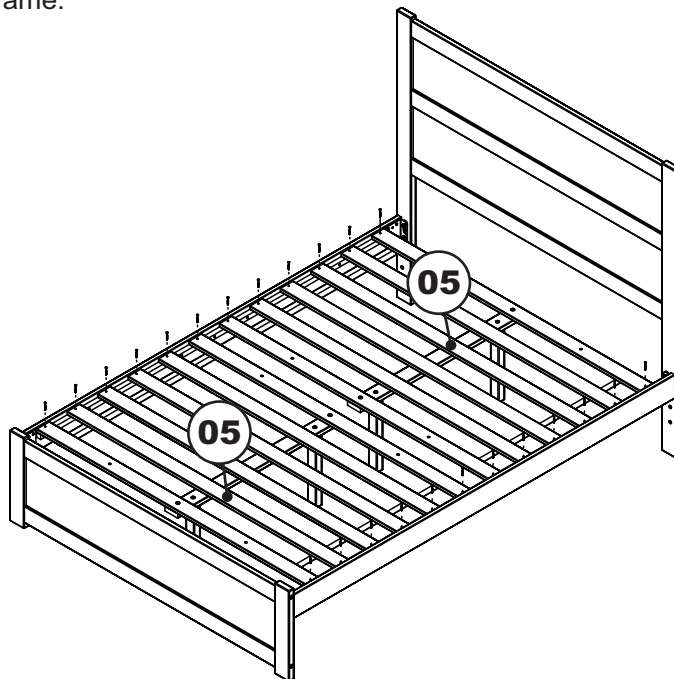

Congratulations!

Your bed is now ready for use.

We recommend that you periodically recheck that all screws are tight to ensure lasting safety.

QUEEN

ASSEMBLY INSTRUCTIONS

Before assembling your bed frame, please read through these instructions carefully and familiarize yourself with the different parts.



ATTENTION! If you receive a damaged or defective item, please contact afifurnishings at customerservice@afifurnishings.com or 1-800-955-3726

PARTS LIST

①	FOOT RAIL	1 PC
②	LEFT LEG	1 PC
③	RIGHT LEG	1 PC
④	SIDE RAILS	2 PCS
⑤	SLAT KIT	2 SETS
⑥	SLAT SUPPORT 1	1 PC
⑦	SLAT SUPPORT 2	1 PC
⑧	SUPPORT LEGS	3 PCS

HARDWARE

①	JCB M6 X 110mm (4 3/8") - 2 pcs	Spare - 1 pc	⑤	JCB M6 X 30mm (1 1/4") - 6pcs
②	Barrel nut - 2 pcs		⑥	Cap nut - 6pcs
③	JCB M8 X 15mm (5/8") - 4 pcs		⑦	Allen wrench M6 - 1pc
④	Wood screw (1 1/4") - 29 pcs	Spare - 2 pcs	⑧	Allen wrench M4 - 1pc
			⑨	Split washer - 3pcs
			⑩	Spare - 1pc
			⑪	Flat washer - 3pcs
			⑫	Spare - 1pc

NOTE: WE INCLUDE SPARE HARDWARE IN CASE DAMAGE OCCURS DURING ASSEMBLY.

Step 1

Attach the legs (2) and (3) to foot rail (1), using JCB M6 X 110mm (A) and barrel nut (B).
Tighten with the Allen wrench M4 (I).

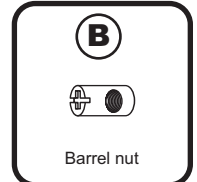
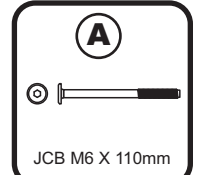
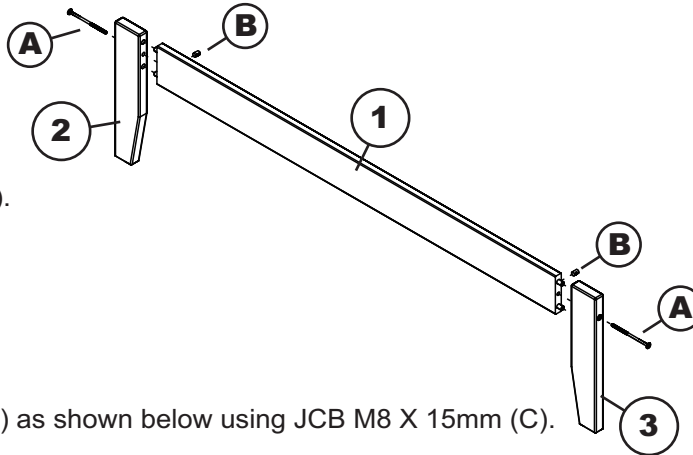

Step 2

Attach side rails (4) to the foot rail (1) as shown below using JCB M8 X 15mm (C).
Tighten with Allen wrench M6 (H).

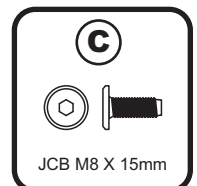
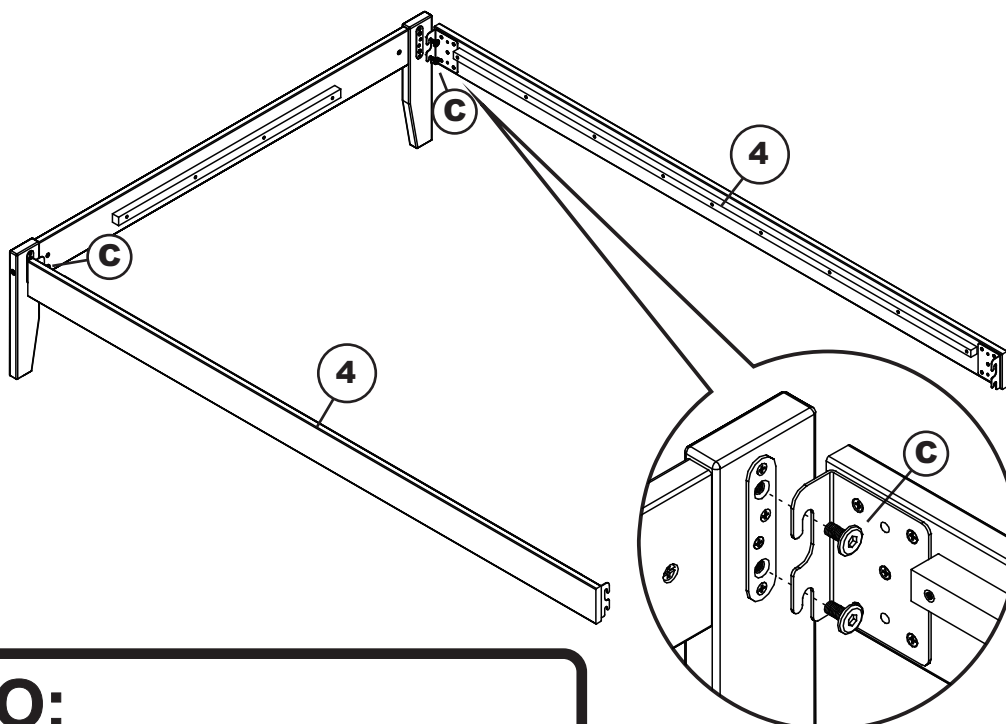

PO:

QUEEN



Step 3

Attach open bed frame to the headboard as shown below using 4 JCB M8 X 15mm bolts that are supplied with your headboard. Tighten with the Allen wrench M6 (H).

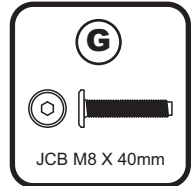
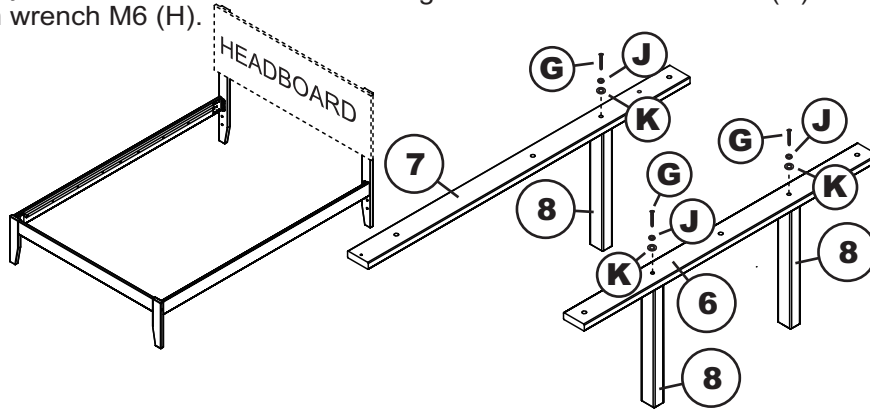
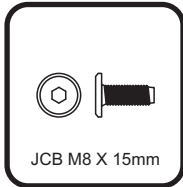

Step 5

Attach slat support 1(6) and slat support 2 (7) to the slat kit (5) as shown below using JCB M6 X 30mm (E) and cap nut (F). Tighten with Allen wrench M4 (I).

2 legs at headboard section.

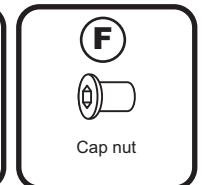
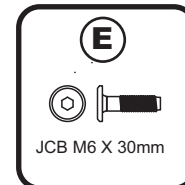
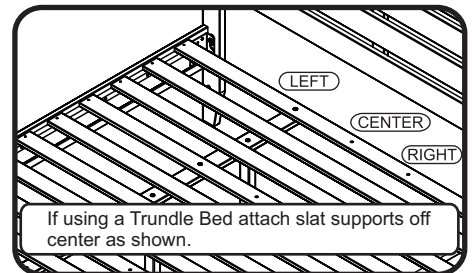
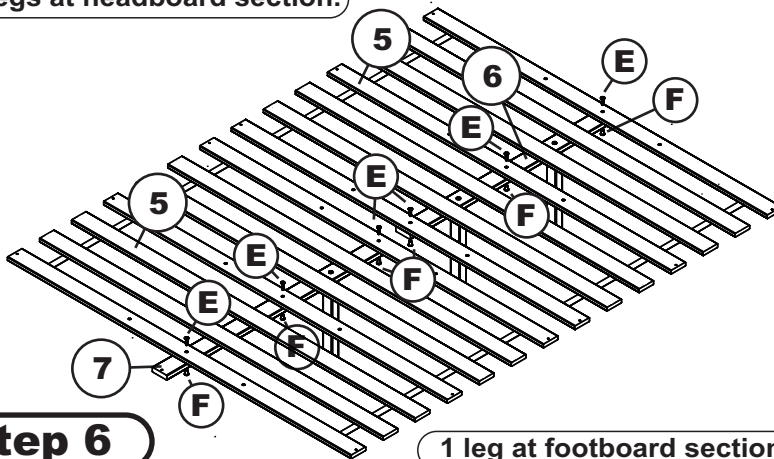

Step 6

Attach 2 slat kits (5) to the open bed frame as shown below using wood screws 1 1/4" (D). Tighten with Phillips head screw driver. (customer supplied)

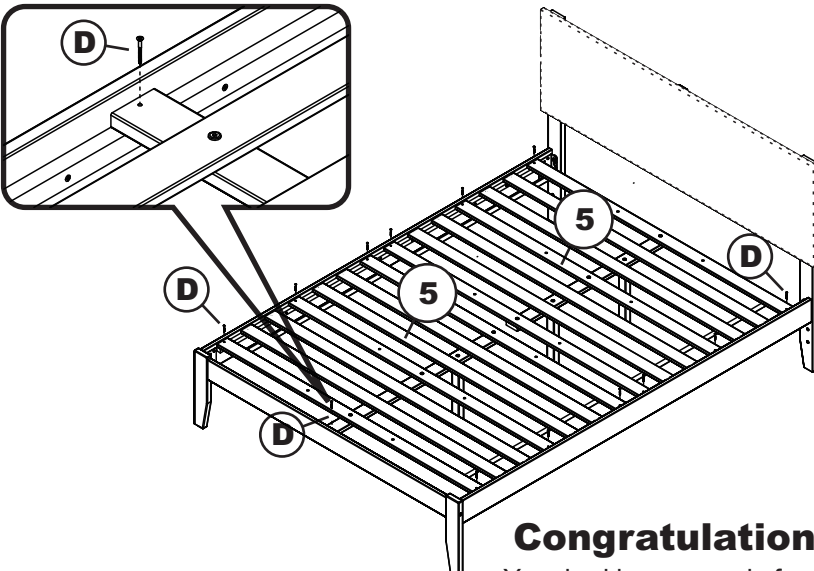

Congratulations!

Your bed is now ready for use.

We recommend that you periodically recheck that all screws are tight to ensure lasting safety.