

## ASSEMBLY INSTRUCTIONS

Before assembling your headboard, please read through these instructions carefully and familiarize yourself with the different parts.

**ATTENTION!** If you receive a damaged or defective item, please contact afifurnishings at [customerservice@afifurnishings.com](mailto:customerservice@afifurnishings.com) or 1-800-955-3726



### PARTS LIST

- ① LEFT POST 1 PC
- ② RIGHT POST 1 PC
- ③ TOP RAIL 1 PC
- ④ MID RAIL 1 PC
- ⑥ BOTTOM RAIL 1 PC

Instructions apply for bed sizes  
TWIN > FULL > QUEEN

### HARDWARE

- Ⓐ JCB M6 X 110mm - 4 pcs  
Spare - 1 pc
  - Ⓑ Barrel Nut - 4 pcs  
Spare - 1 pc
  - Ⓒ JCB M8 X 15mm ( 5/8" ) - 4 pcs  
Spare - 1 pc
  - Ⓓ Wood Dowel - 10 pcs  
Spare - 1 pc
  - Ⓔ Allen wrench - 1pc  
Spare - 1pc
- Assembly headboard to open bed frame*

#### HARDWARE FOR METAL BED FRAME

- Ⓕ JCB M6 X 25mm (1") - 4 pcs  
Spare - 1 pc
- Ⓖ Flat washer - 4 pcs  
Spare - 1 pc
- Ⓗ Split washer - 4 pcs  
Spare - 1 pc

NOTE: WE INCLUDE SPARE HARDWARE IN CASE DAMAGE OCCURS DURING ASSEMBLY.

### Step 1

Insert all wooden dowels (D) into the locator holes on (3)(4) and(5) as shown below.

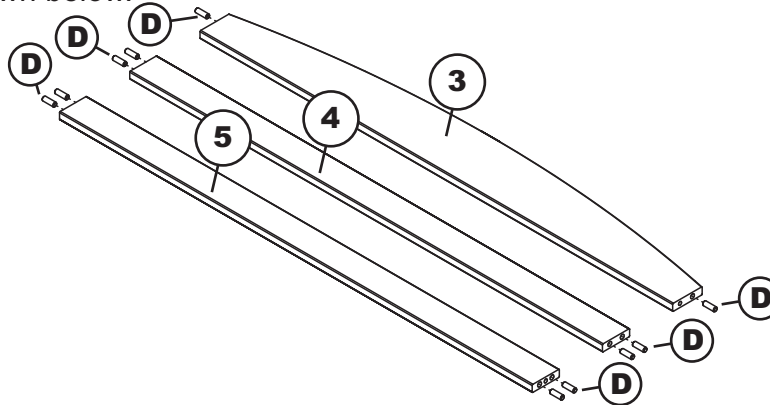

Adult assembly

Ⓓ



Wood Dowel

### Step 2

Lay the left post (1) bracket face down on smooth surface. Connect top rail (3), mid rail (4) and bottom rail (5) as shown below, using JCB M6 X 110mm (A) and barrel nut (B). Tighten with the Allen wrench (E).

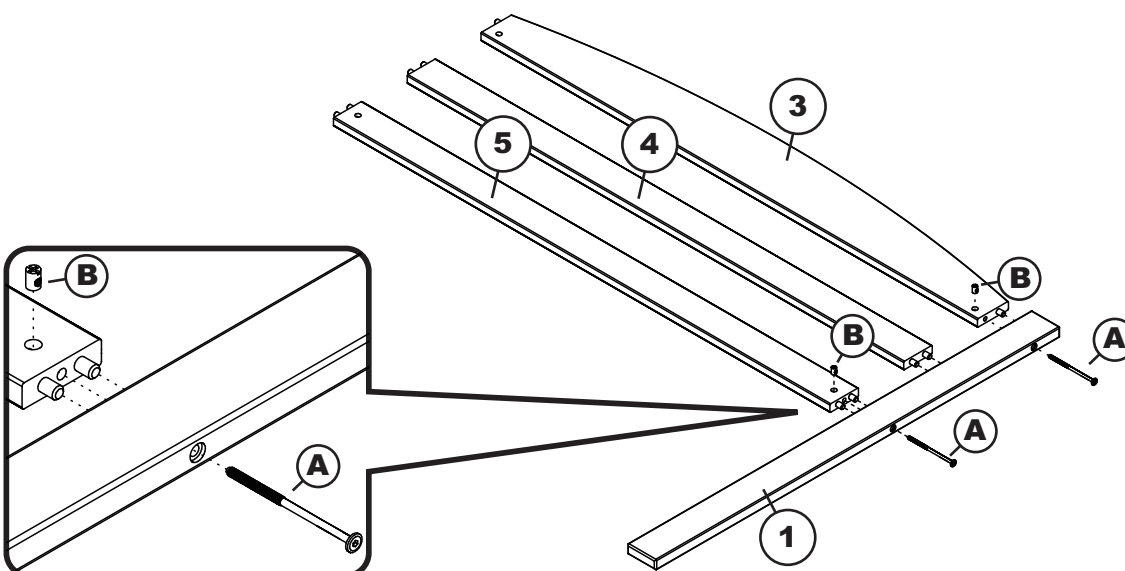

Adult assembly

Ⓐ



JCB M6 X 110mm

Ⓑ



Barrel Nut

PO:

CODE	ITEM	ITEM	ITEM
HB-ISL-WRN	G-11902X	G-11903X	G-11904X

### Step 3

Attach the right post (2) to headboard assembly as shown below, using JCB M6 X 110mm (A) and barrel nut (B). Tighten with Allen wrench (E)

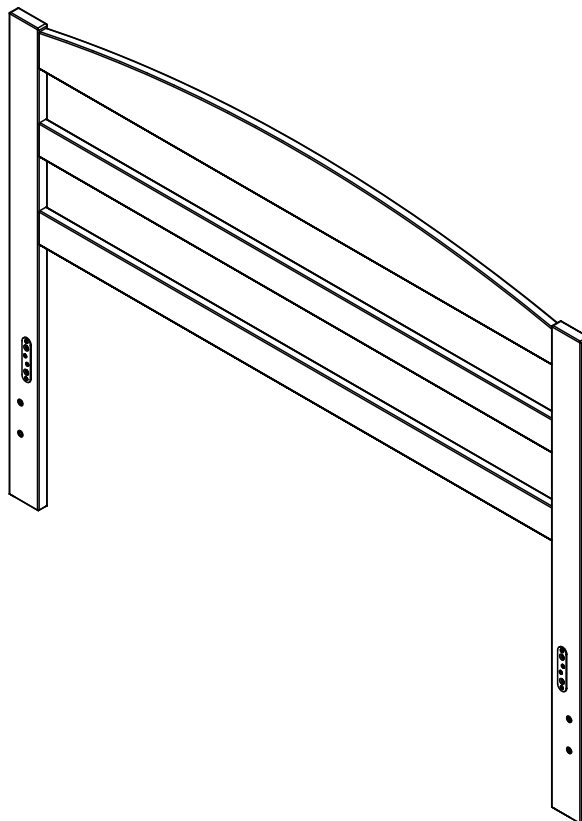
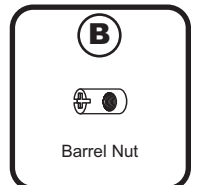
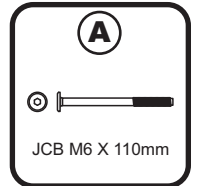
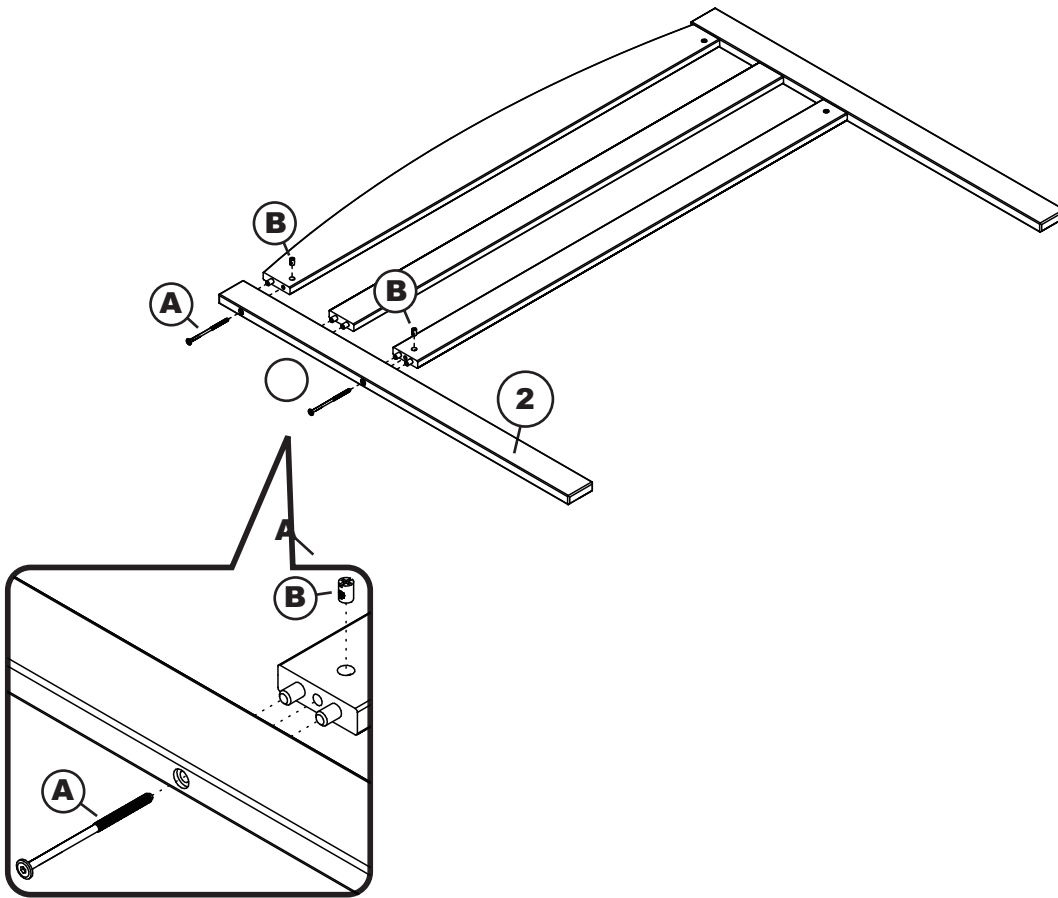

FOR BED FRAME ASSEMBLY follow assembly instructions included with your bed frame.  
If you purchased a wood headboard to attach to metal bed frame, please refer to page 3.

## FULL ASSEMBLY INSTRUCTIONS

Before assembling your bed frame, please read through these instructions carefully and familiarize yourself with the different parts.



**ATTENTION!** If you receive a damaged or defective item, please contact afifurnishings at [customerservice@afifurnishings.com](mailto:customerservice@afifurnishings.com) or 1-800-955-3726

### PARTS LIST

①	<b>FOOT RAIL</b>	<b>1 PC</b>
②	<b>LEFT LEG</b>	<b>1 PC</b>
③	<b>RIGHT LEG</b>	<b>1 PC</b>
④	<b>SIDE RAILS</b>	<b>2 PCS</b>
⑤	<b>SLAT KIT</b>	<b>2 SETS</b>
⑥	<b>SLAT SUPPORT 1</b>	<b>1 PC</b>
⑦	<b>SLAT SUPPORT 2</b>	<b>1 PC</b>
⑧	<b>SUPPORT LEGS</b>	<b>3 PCS</b>

### HARDWARE

①	JCB M6 X 110mm (4 3/8") - 2 pcs Spare - 1 pc	⑤	JCB M6 X 25mm(1") - 4pcs
②	Barrel nut - 2 pcs	⑥	Cap nut - 4pcs
③	JCB M8 X 15mm ( 5/8") - 4 pcs	⑦	Allen Screw - 3pcs
④	Wood screw(1 1/4") - 25 pcs Spare - 2 pcs	⑧	Allen wrench M6 - 1pc
		⑨	Allen wrench M4 - 1pc Spare - 1pc

NOTE: WE INCLUDE SPARE HARDWARE IN CASE DAMAGE OCCURS DURING ASSEMBLY.

### Step 1

Attach the legs (2) and (3) to foot rail (1), using JCB M6 X 110mm (A) and barrel nut (B).  
Tighten with the Allen wrench M4 (I).

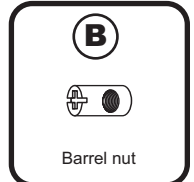
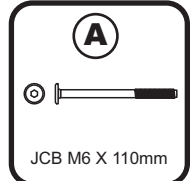
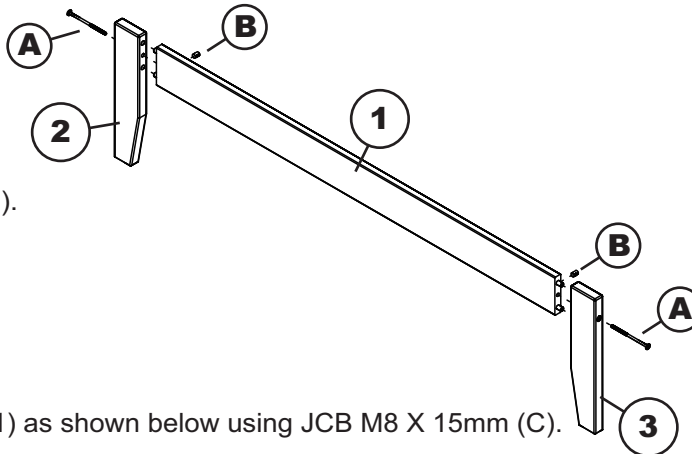

### Step 2

Attach side rails (4) to the foot rail (1) as shown below using JCB M8 X 15mm (C).  
Tighten with Allen wrench M6 (H).

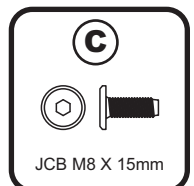
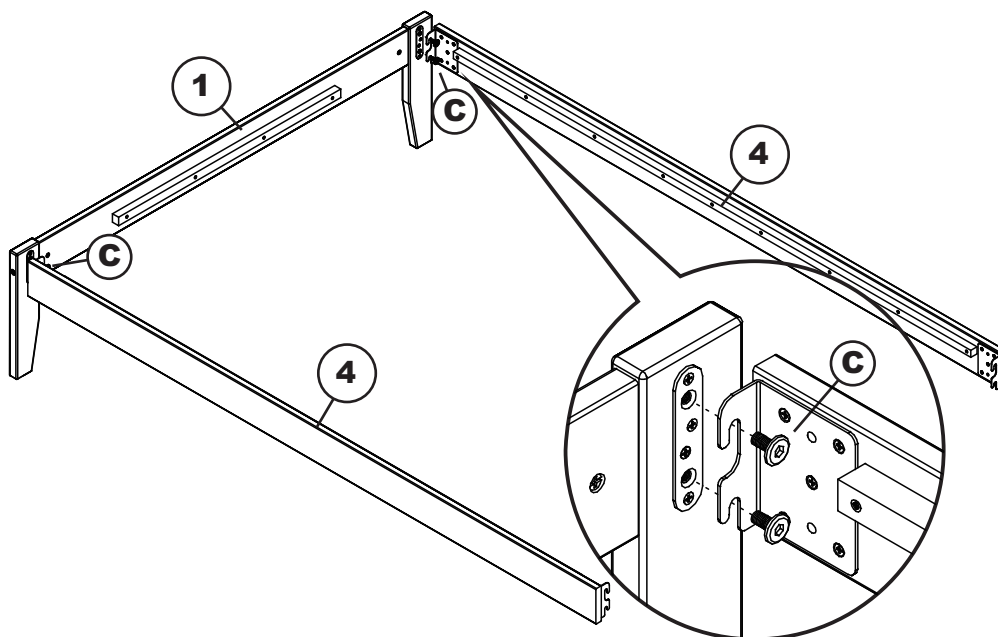

PO:

CODE ITEM  
FR-OP-ISL G-21803X

## FULL



### Step 3

Attach open bed frame to the headboard as shown below using 4 JCB M8 X 15mm bolts that are supplied with your headboard. Tighten with the Allen wrench M6 (E).

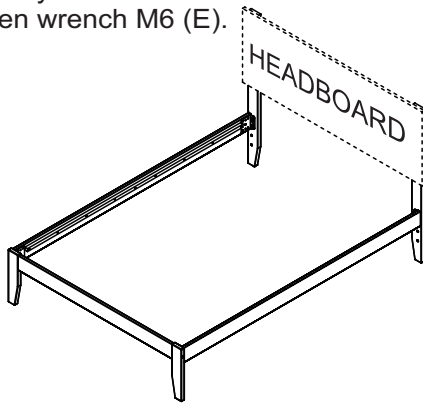
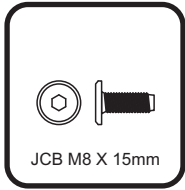

### Step 4

Attach support legs (8) to slat support 1 & 2 (6)(7) as shown below using Allen screw (G) tighten with Allen wrench M4 (I).

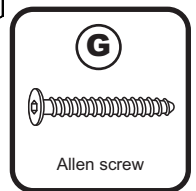
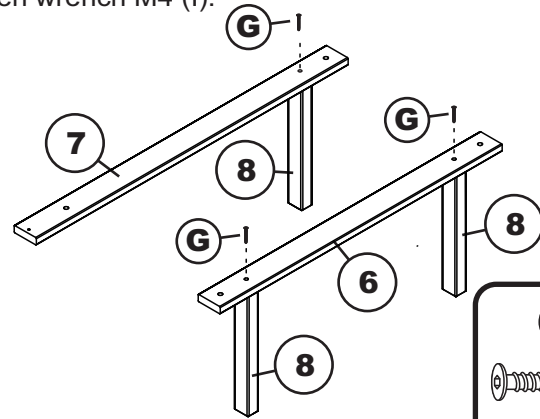

### Step 5

Attach slat support 1(6) and slat support 2 (7) to the slat kit (5) as shown below using JCB M6 X 25mm (E) and cap nut (F). Tighten with Allen wrench M4 (I).

2 legs at headboard section.

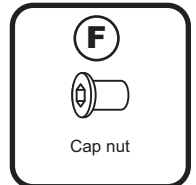
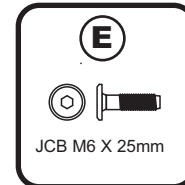
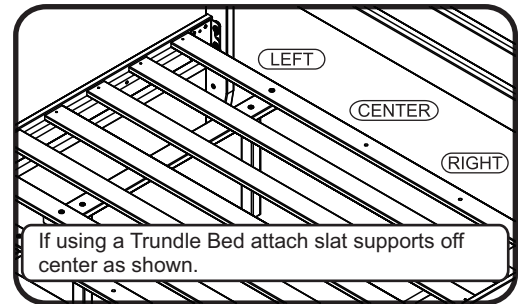
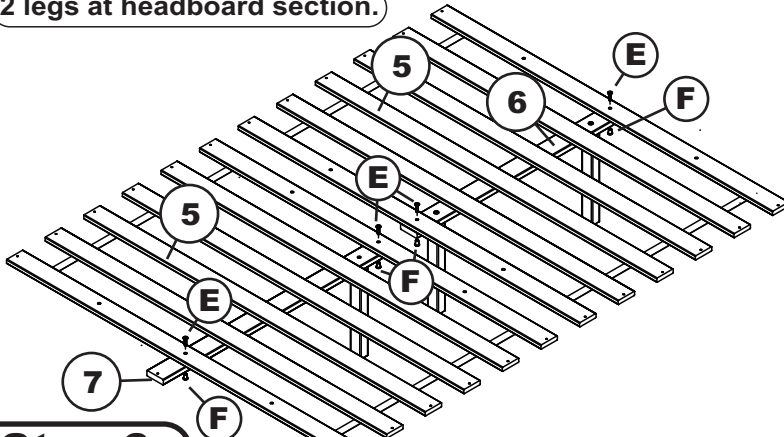

### Step 6

1 leg at footboard section.

Attach 2 slat kits (5) to the open bed frame as shown below using wood screws 1 1/4" (D). Tighten with Phillips head screw driver. (customer supplied)

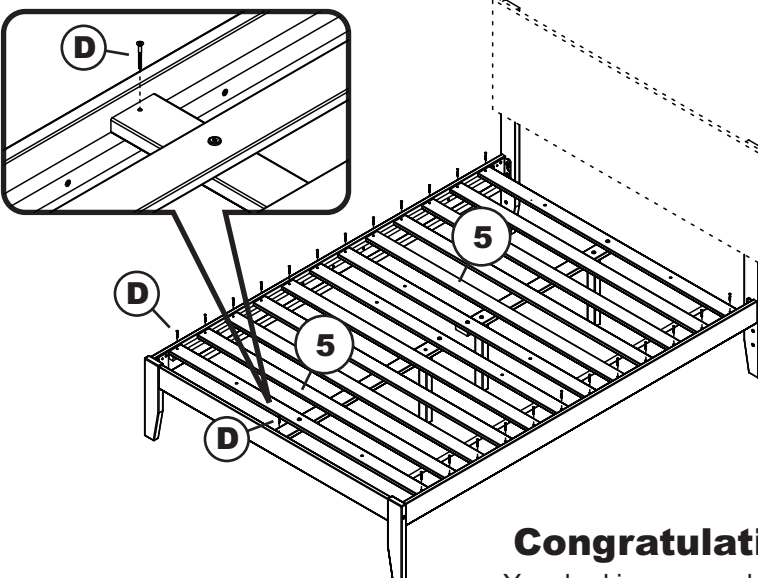

## Congratulations!

Your bed is now ready for use.

We recommend that you periodically recheck that all screws are tight to ensure lasting safety.

## FULL ASSEMBLY INSTRUCTIONS

Before assembling your bed drawer, please read through these instructions carefully, familiarize yourself with the different parts.

**ATTENTION!** If you receive a damaged or defective item, please contact afifurnishings at customerservice@afifurnishings.com or 1-800-955-3726

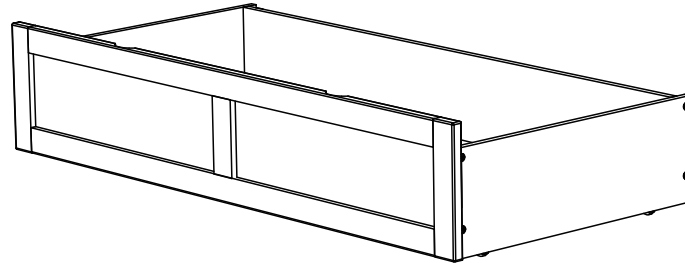
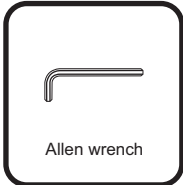

**NOTE: WE INCLUDE SPARE HARDWARE IN CASE DAMAGE OCCURS DURING ASSEMBLY.**

**HARDWARE**



**(A)** JCB M6 X 1" ( 25mm ) - 8 pcs  
Spare - 1 pc



**(B)** Wood Screw X 1 1/4" ( 32mm ) - 2 pcs  
Spare - 1 pc



**(C)** Allen wrench - 1 pc  
Spare - 1 pc

### PARTS LIST

- (01) HARDWARE 1 BOX**
- (02) DRAWER FACE 1 PC**
- (03) DRAWER SIDE 2 PCS**
- (04) DRAWER BACK 1 PC**
- (05) DRAWER BOTTOM 2 PCS**
- (06) DRAWER MIDDLE 1 PC**
- (07) DRAWER CENTER SUPPORT 1 PC**

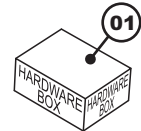
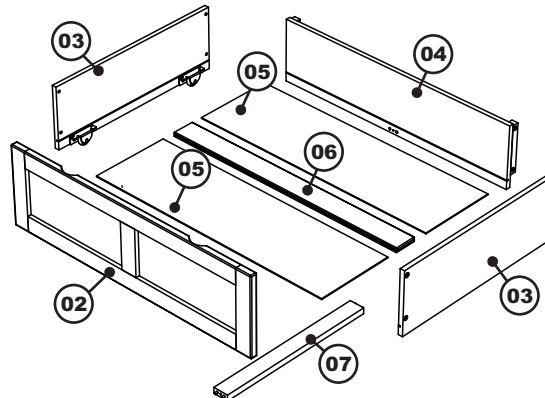

**Step 1** Lay the drawer face (02) on smooth, flat surface so the drawer bottom (05) groove is facing upwards. Attach the drawer sides (03) to drawer face (02) using JCB M6 X 1" (A). Align groove inside drawer side with groove in drawer face. Tighten with Allen wrench (C).

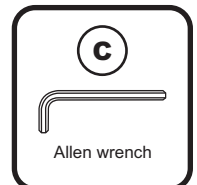
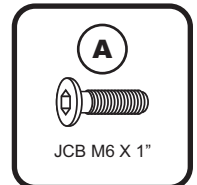
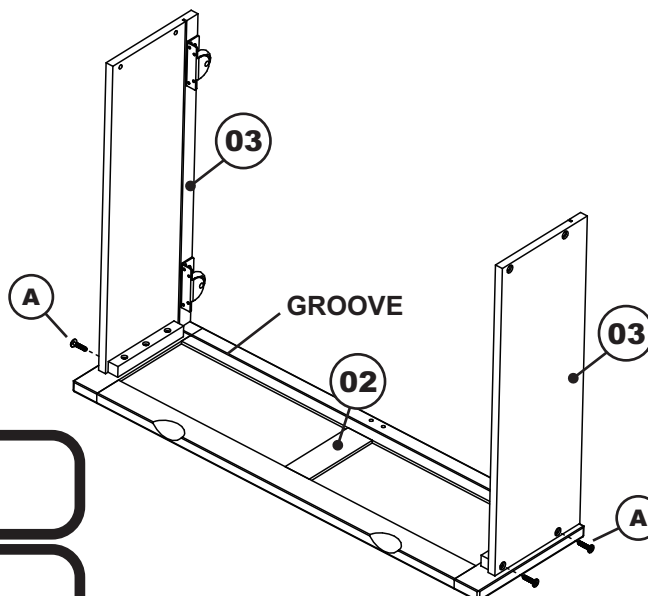

CODE	ITEM
ST-DR1-ISL	G-31803X

**PO :**

## FULL

### Step 2

Guide the drawer bottoms (05) and drawer middle (06) in carefully so that they align inside grooves. Be sure it fits fully into the face and side groove before attaching the drawer back (04). Attach drawer center support (07) to bottom of drawer face using wood screw 1 1/4" (B). Tighten with Phillips head screw driver. (Customer supplied)

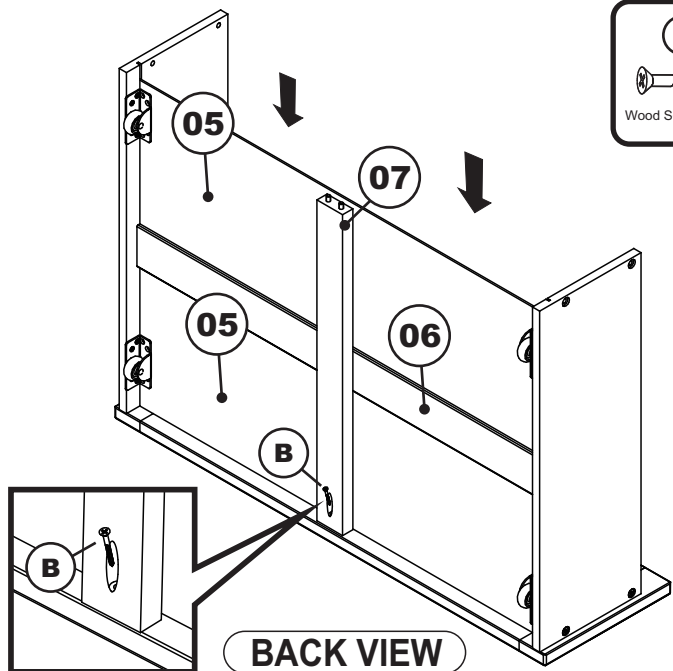
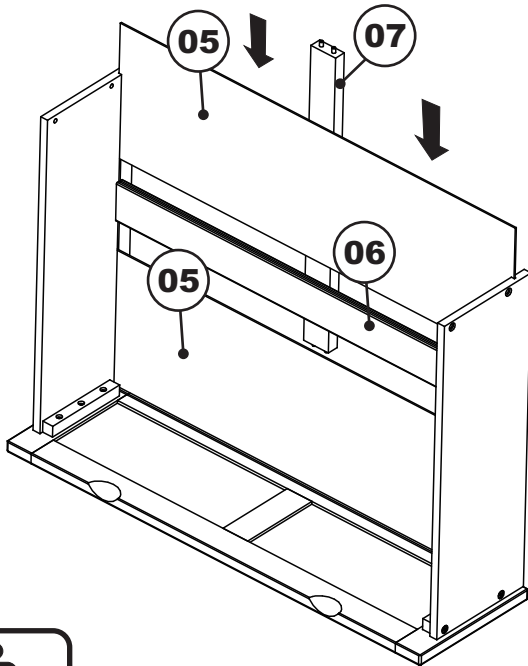

Adult assembly

### Step 3

Attach drawer back (04) to bed drawer assembly as shown. Use JCB M6 X 1" (A). Tighten with Allen wrench (C). Use wood screws 1 1/4" (B) to finish attaching drawer center support (07) to drawer back (04). Tighten with Phillips head screw driver. (customer supplied)

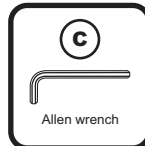
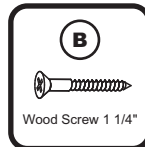
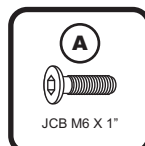
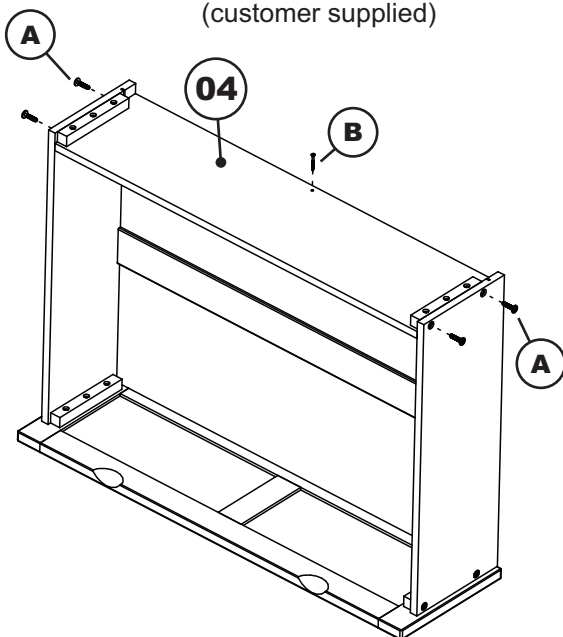

## Congratulations!

Your bed drawer is now ready for use.  
We recommend that you periodically recheck that all screws are tight to ensure lasting safety.



Adult assembly