

QUEEN

ASSEMBLY INSTRUCTIONS

Before assembling your murphy bed, please read through these instructions carefully and familiarize yourself with the different parts.

ATTENTION! If you receive a damaged or defective item, please contact affurnishings at customerservice@afifurnishings.com or 1-800-955-3726

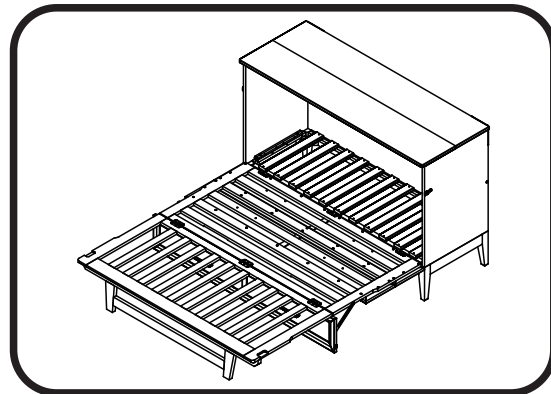
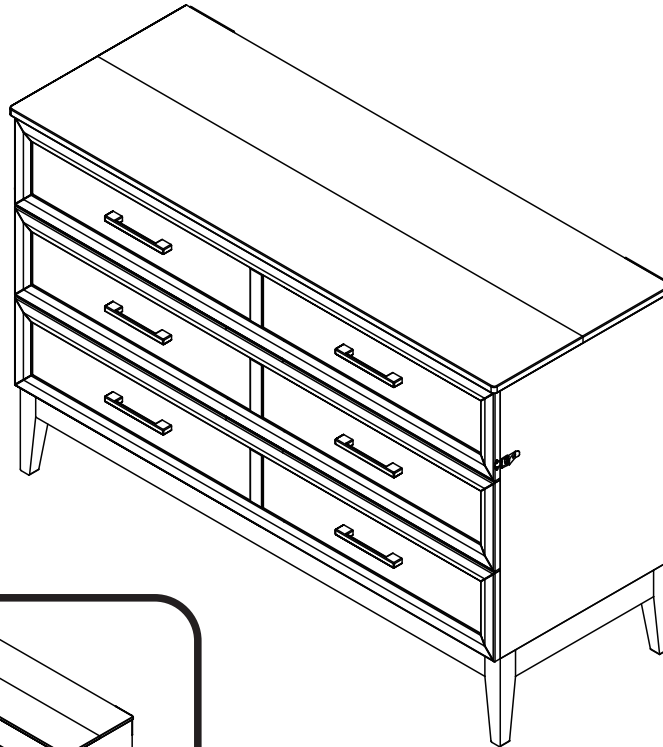

CODE	ITEM
MB-PD-SAN	C-7741X
MB-BL-SAN	C-7742X
MB-TP-SAN	C-7743X

PO :

HARDWARE

NOTE: WE INCLUDE SPARE HARDWARE IN CASE DAMAGE OCCURS DURING ASSEMBLY.

- A** JCB M6 X 30mm (1 1/4") - 8 pcs
Spare - 1 pc
- B** JCB M6 X 55mm (2 1/8") - 2 pcs
Spare - 1 pc
- C** Wood screw 1" - 17 pcs
Spare - 2 pcs
- D** Flat Washer - 8 pcs
Spare - 2 pcs
- E** Hexagon Nut - 8 pcs
Spare - 1 pc
- F** Barrel Nut - 2 pcs
- G** Hexagon wrench - 1 pc
- H** Spring clip set with screw - 2 pcs
- I** Triangle Bracket - 2 pcs
- J** Surface Mount Charger 2 - 1 set
Screw 1/2" - 2 pcs
Spare - 1 pc
- K** Allen wrench - 1 pc
Spare - 1 pc

QUEEN

PARTS LIST

- 01 HARDWARE
- 02 SMC2
- 03 LEFT SIDE PANEL
- 04 RIGHT SIDE PANEL — 1 BOX C-7742X
- 05 BASE
- 06 LEG
- 07 BACK RAIL — 1 BOX C-7743X
- 08 BACK PANEL
- 09 TOP PANEL
- 10 FOLDING PANEL — 1 BOX C-7741X

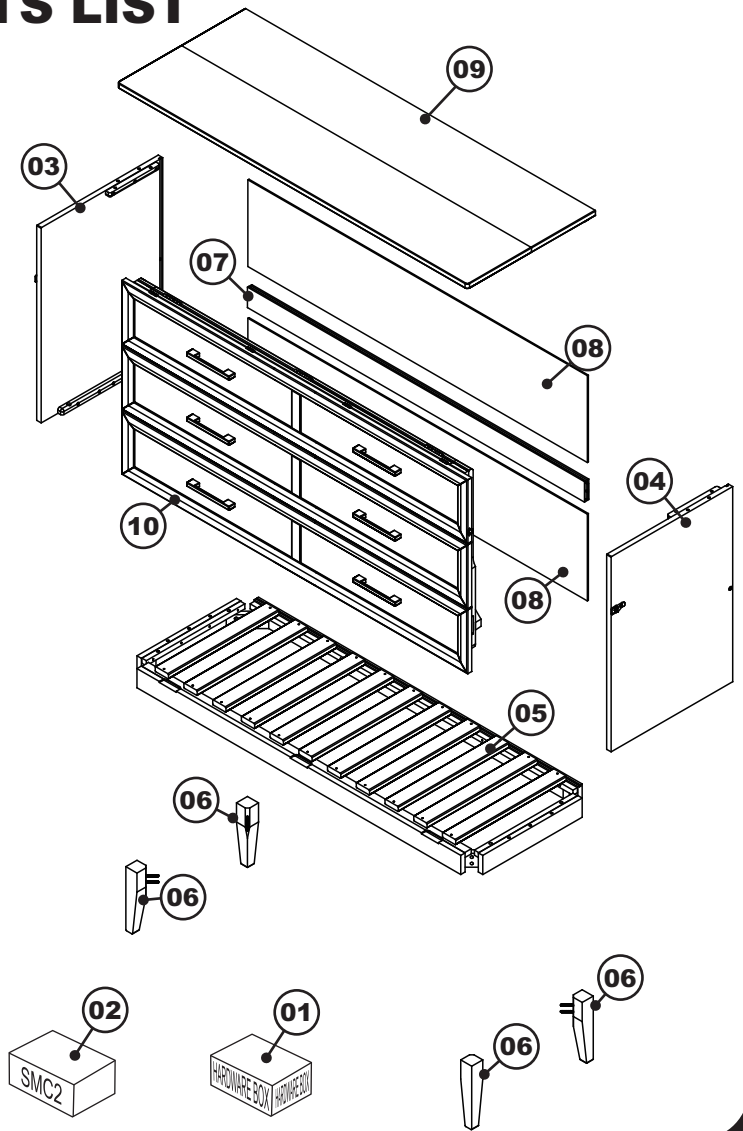

STEP 1

Install spring clip (H) set with screw to side panels (03)(04). Attach left side panel (03) and right side panel (04) to the base (05) as shown below. Use JCB (A). Tighten with Allen wrench (K)

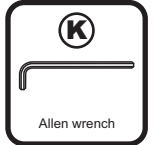
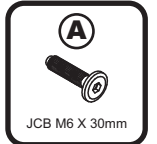
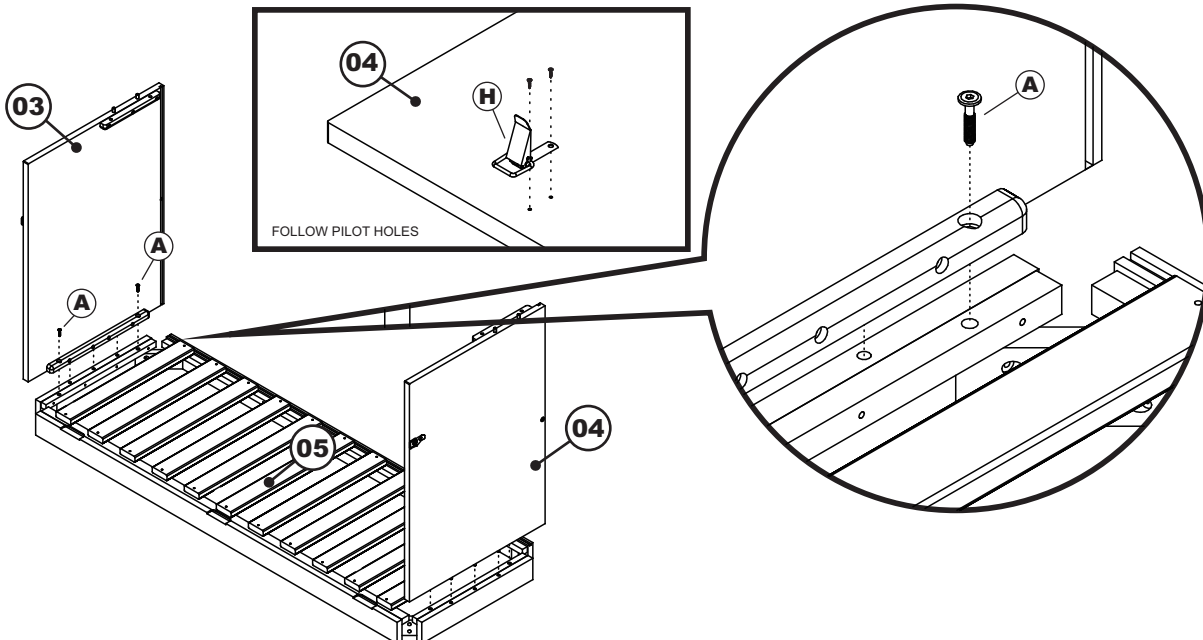

QUEEN

STEP 2

Guide the back panel (08) and back rail (07) in carefully so that it won't jump out of its grooves. Be sure it fits fully into its groove at the back rail before fitting the top panel. Use JCB (B) and barrel nut (F). Tighten with allen wrench (K).

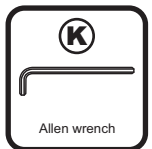
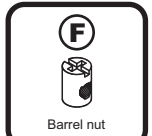
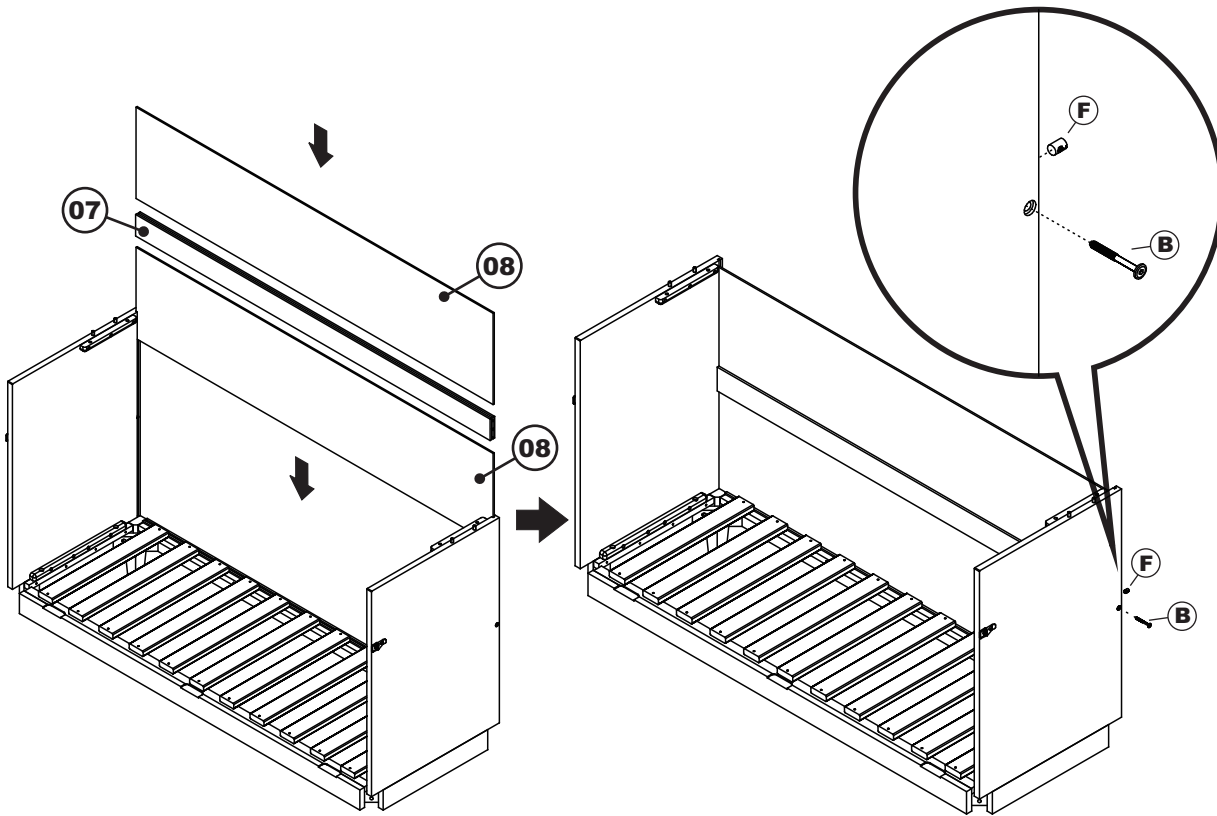

STEP 3

Attach top panel (09) to cabinet assembly as shown below. Use JCB (A). Tighten with Allen wrench (K)

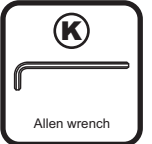
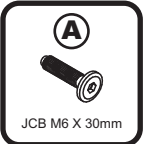
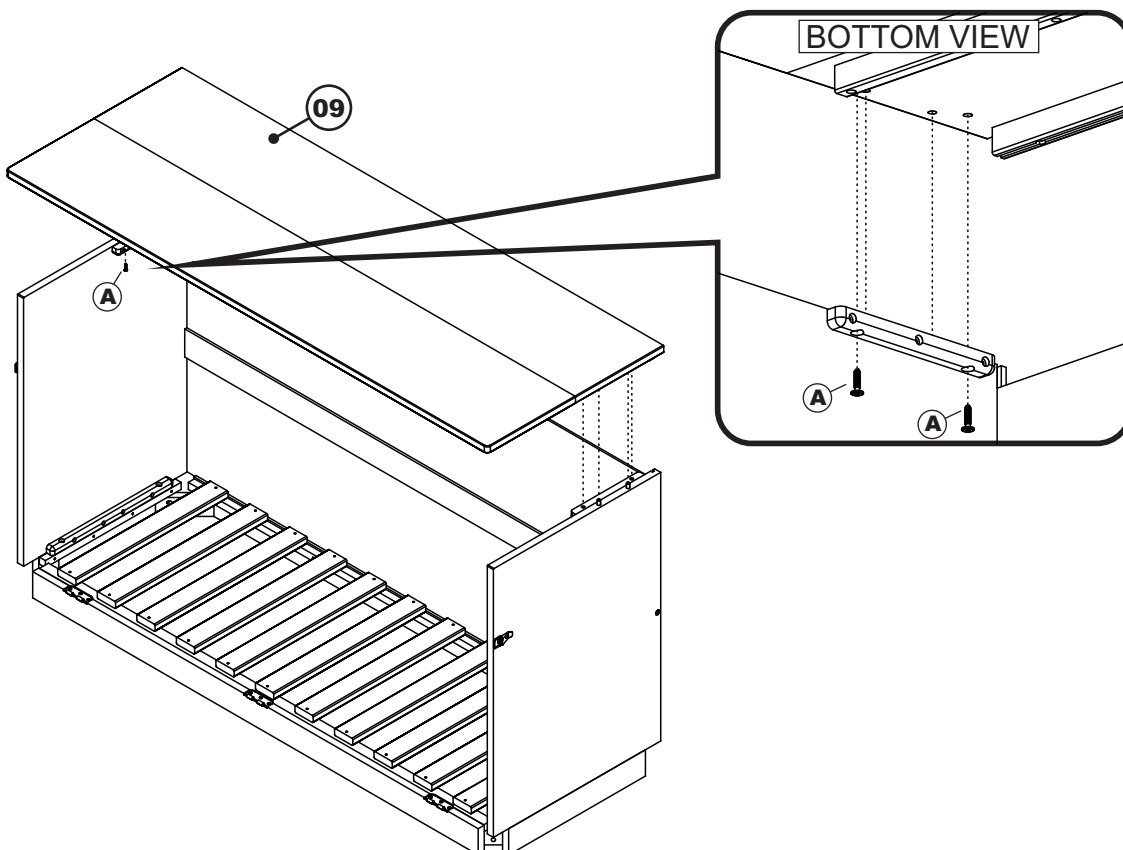

QUEEN

STEP 4

Attach legs (06) to cabinet assembly as shown below. Use flat washer (D) and hexagon nut (E). Tighten with Hexagon wrench (G)

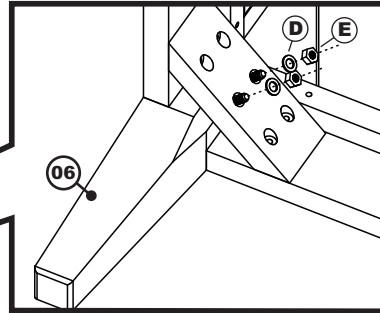
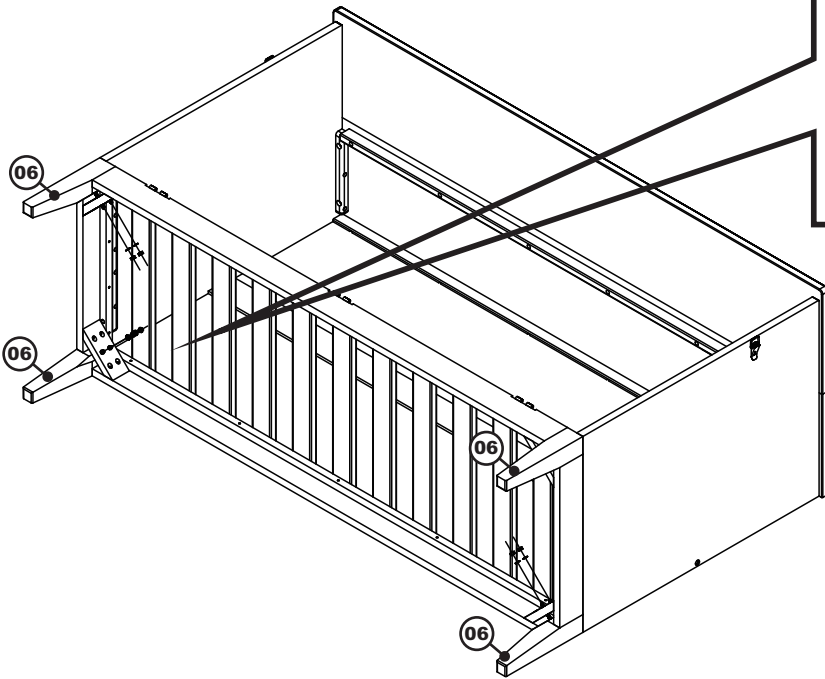

STEP 5

Open top drawer folding leg as shown below. Using metal support and lock to the post. (both side)

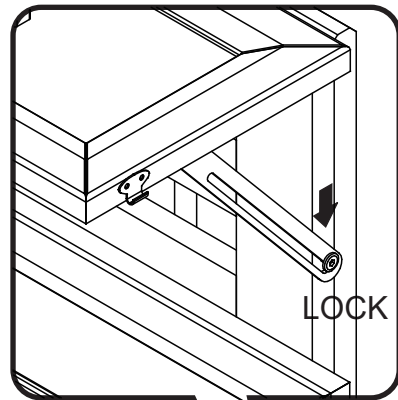
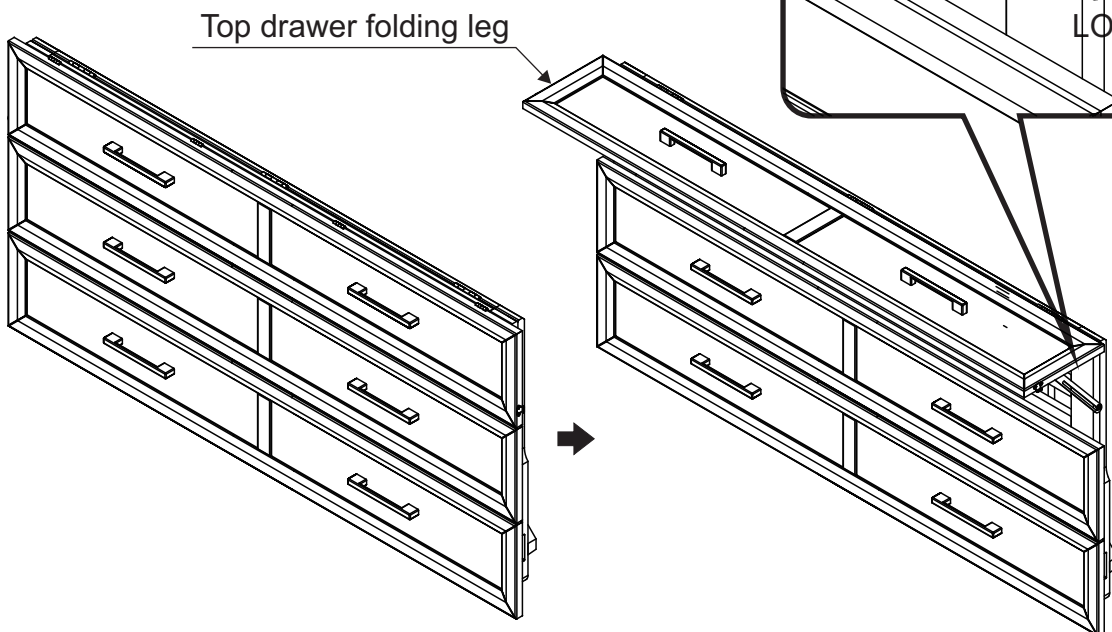

QUEEN

STEP 6

Attach folding panel assembly (10) to cabinet assembly as shown below. Use wood screw (C). Tighten with Phillips head screwdriver. Customer supplied. Be sure to align with cabinet.

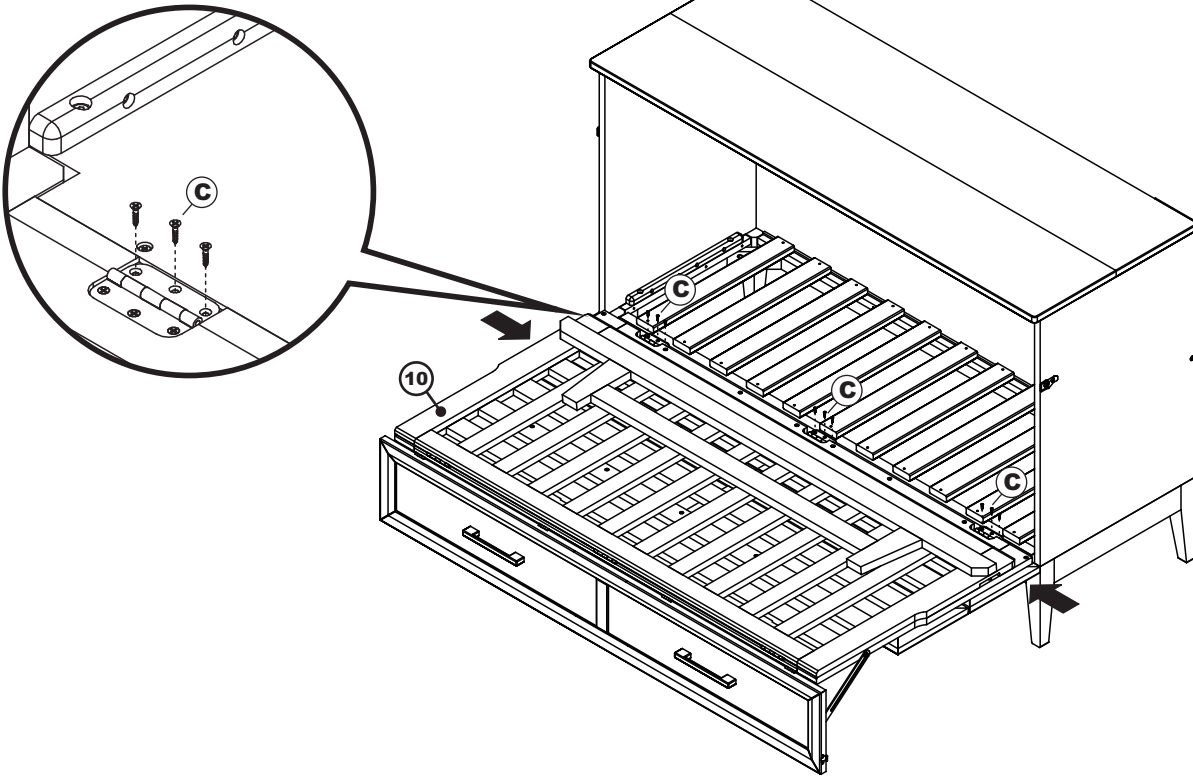

STEP 7

Unlock metal support. Lift the door and latch to side panel. Push the door closed and latch both sides as shown below.

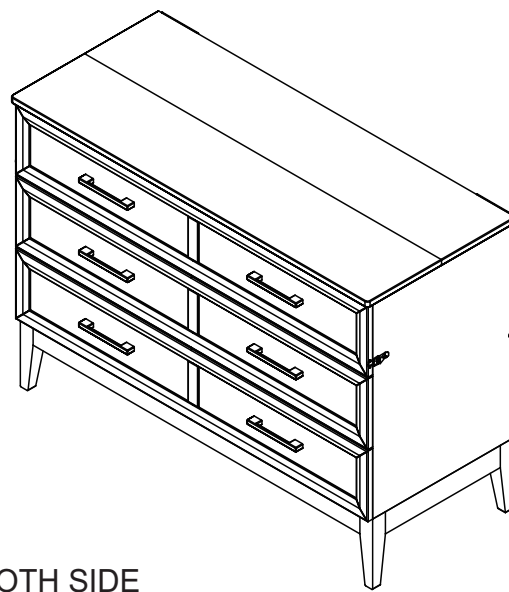
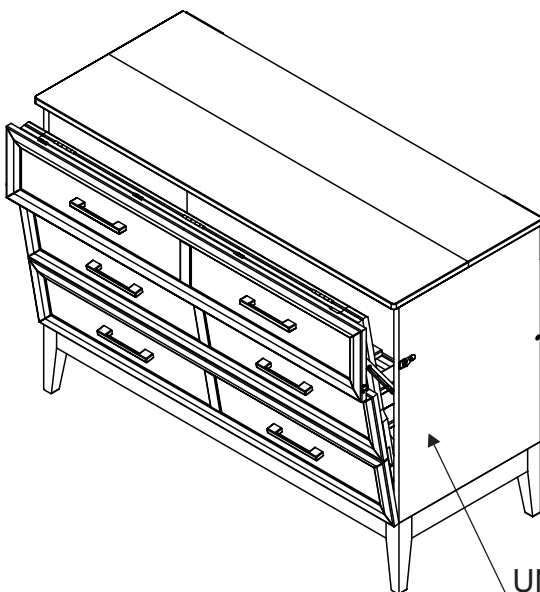
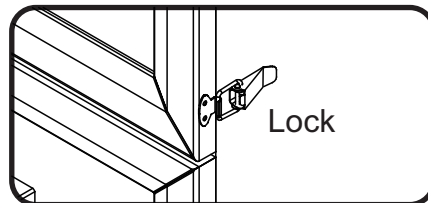
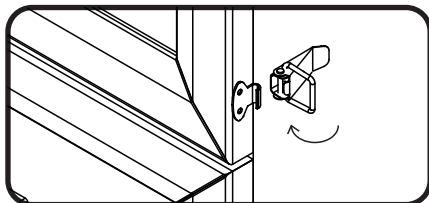

UNLOCK BOTH SIDE



QUEEN

STEP 8

Attach triangle bracket (I) to the back of cabinet as shown below. Use wood screw (C) tighten with Phillips head screwdriver. (customer supplied).

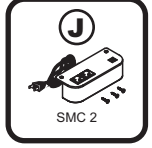
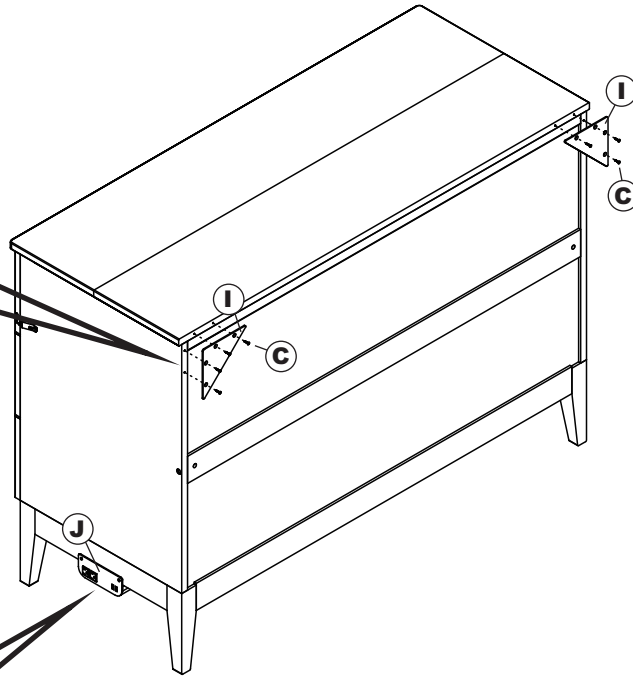
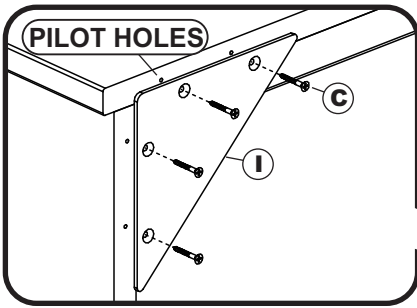

STEP 9

Install USB charger (J) to the location as shown. Using 1/2" screws and tighten with Phillips head screwdriver. (Customer supplied)

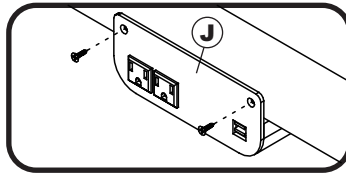

STEP 10

Unlatch the door and open, folding down and lock metal support to the post as shown.

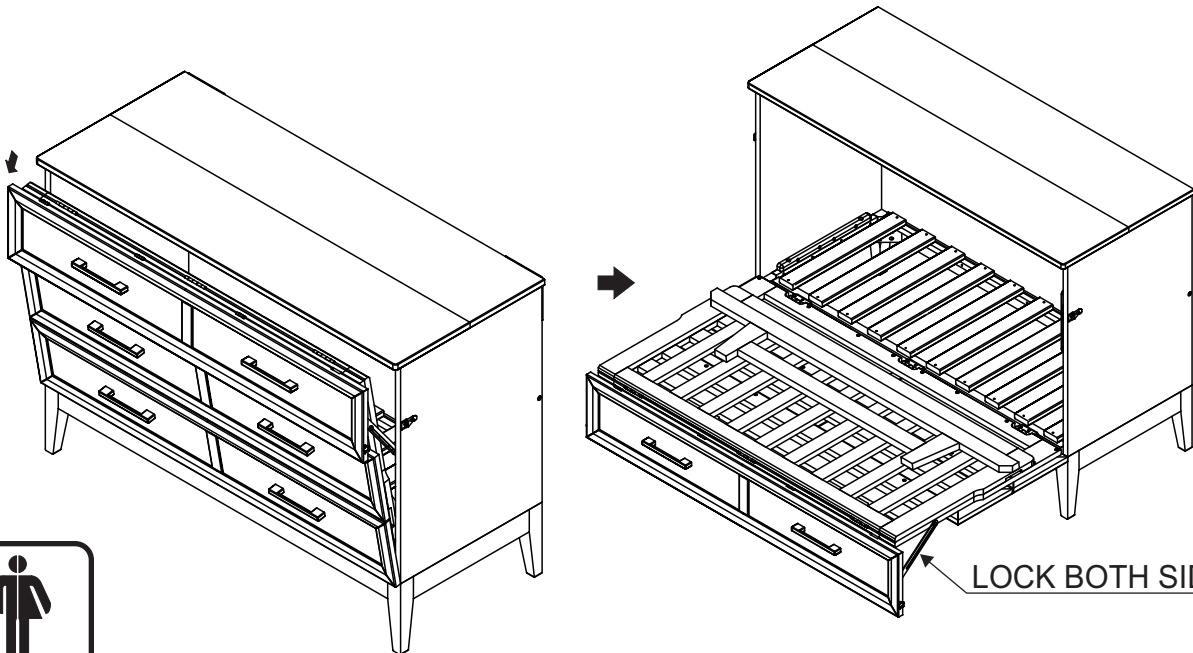
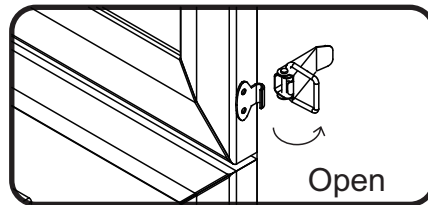
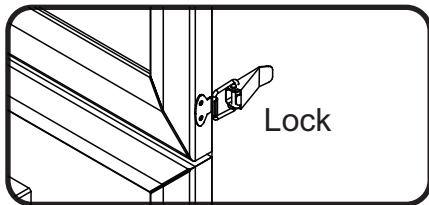

QUEEN

STEP 11

Open and pull footboard frame and open footboard leg as shown below.

